



EN 50131-1  
EN 50131-10  
EN 50136-1  
EN 50136-2  
EN 50130-4  
EN 50130-5  
CEB T014



## SmartLink Advanced Telephone dialler

Installation and programming manual



GameOver

**inim**<sup>®</sup>  
ELECTRONICS

INIM Electronics s.r.l. (Seller, Our, Us) warrants the original purchaser that this product shall be free from defects in materials and workmanship under normal use for a period of 24 months. As INIM Electronics s.r.l. does not install this product directly, and due to the possibility that it may be used with other equipment not approved by Us; INIM Electronics s.r.l. does not warrant against loss of quality, degradation of performance of this product or actual damage that results from the use of products, parts or other replaceable items (such as consumables) that are neither made nor recommended by INIM Electronics. Seller obligation and liability under this warranty is expressly limited to repairing or replacing, at Seller's option, any product not meeting the specifications. In no event shall INIM Electronics s.r.l. be liable to the purchaser or any other person for any loss or damage whether direct or indirect or consequential or incidental, including without limitation, any damages for lost profits, stolen goods, or claims by any other party caused by defective products or otherwise arising from the incorrect or otherwise improper installation or use of this product.

This warranty applies only to defects in parts and workmanship relating to normal use. It does not cover:

- damage arising from improper maintenance or negligence
- damage caused by fire, flood, wind or lightning
- vandalism
- fair wear and tear

INIM Electronics s.r.l. shall, at its option, repair or replace any defective products. Improper use, that is, use for purposes other than those mentioned in this manual will void the warranty. Contact Our authorized dealer, or visit our website for further information regarding this warranty.

INIM Electronics s.r.l. shall not be liable to the purchaser or any other person for damage arising from improper storage, handling or use of this product.

Installation of this Product must be carried out by qualified persons appointed by INIM Electronics. Installation of this Product must be carried out in accordance with Our instructions in the product manual.

The information contained in this document is the sole property of INIM Electronics s.r.l. No part may be copied without written authorization from INIM Electronics s.r.l.

All rights reserved.

Hereby INIM Electronics s.r.l. declares that the SmartLinkAdv/P, SmartLinkAdv/G and SmartLinkAdv/GP are in compliance with the essential requirements and other relevant provisions of Directive 1999/5/CE.

The full declarations of conformity of the above-mentioned devices are available at URL:

[www.inim.biz/certifications](http://www.inim.biz/certifications)

## Warranty

## Limited warranty

## Copyright

## Directive 1999/5/CE (R&TTE) compliance

## Table of contents

	Warranty . . . . .	2
	Limited warranty . . . . .	2
	Copyright . . . . .	2
	Directive 1999/5/CE (R&TTE) compliance . . . . .	2
	Table of contents . . . . .	3
	About this manual . . . . .	5
0-1	Terminology . . . . .	5
0-2	Graphic conventions . . . . .	5
Chapter 1	General information . . . . .	6
1-1	Manufacturer's details . . . . .	6
1-2	Description of the product and various models . . . . .	6
1-3	Supplied documentation . . . . .	8
Chapter 2	Device description . . . . .	9
2-1	Unpacking the device . . . . .	9
2-2	Accessory items . . . . .	9
2-3	Technical description . . . . .	9
2-4	Signalling from device . . . . .	11
Chapter 3	SmartLinkAdv functions . . . . .	13
3-1	Telephone line down management . . . . .	13
3-2	Input/Output terminals . . . . .	13
3-3	Event activations . . . . .	14
3-4	Dialler function . . . . .	14
3-5	Command and Shortcuts . . . . .	15
3-6	Remote activation . . . . .	15
3-7	Easyscan . . . . .	17
3-8	Jamming detector . . . . .	17
Chapter 4	Installation . . . . .	18
4-1	Wall-mounting . . . . .	18
4-2	Connecting to the mains power supply . . . . .	18
4-3	Mounting the antenna . . . . .	19
4-4	Telephone connections . . . . .	20

---

4-5	Earth connection . . . . .	20
4-6	Inserting the SIM card . . . . .	20
4-7	PC Connection . . . . .	21
4-8	Wiring and balancing alarm detectors . . . . .	22
4-9	Connecting the outputs . . . . .	25
<b>Chapter 5</b>	<b>First power up . . . . .</b>	<b>26</b>
5-1	Initializing phase. . . . .	26
5-2	Easyscan procedure. . . . .	26
<b>Chapter 6</b>	<b>Project development and programming. . . . .</b>	<b>28</b>
6-1	Using the SmartLeague software program . . . . .	28
6-2	Using the software program . . . . .	29
6-3	Programming via the software . . . . .	30
6-4	Reset default settings . . . . .	31
6-5	Maintenance and monitoring. . . . .	31
<b>Chapter 7</b>	<b>EN50136 Compliance . . . . .</b>	<b>33</b>
7-1	ATS Categories . . . . .	33
7-2	Access Levels . . . . .	34
7-3	Connection with alarm control panel (Control and Indicating Equipment) . . . . .	34
<b>Appendix A</b>	<b>Events . . . . .</b>	<b>36</b>
<b>Appendix B</b>	<b>Declaration of conformity . . . . .</b>	<b>38</b>
	Notes . . . . .	39

## ABOUT THIS MANUAL

DCMIINEOSLINKA **MANUAL CODE**1.70 **VERSION**

### Terminology **0-1**

A device which sends voice calls or digital reports to programmed contact numbers in the event of an alarm. **DIALER**

If not otherwise specified, refers to the SmartLinkAdv. **DEVICE**

Persons whose training, expertise and knowledge of the products and laws regarding security systems, are able to create, in accordance with the requirements of the purchaser, the most suitable solution for the protected premises. **QUALIFIED PERSONNEL**

Directions as seen by the operator when directly in front of the mounted device. **LEFT, RIGHT, BEHIND, ABOVE, BELOW**

Click on a specific item on the interface (drop-down menu, options box, graphic object, etc.). **SELECT**

Click on a video button, or push a key on the control-panel keypad. **PRESS**

### Graphic conventions **0-2**

Following are the graphic conventions used in this manual.

Conventions	Example	Description
Text in italics	Refer to <i>paragraph 0-2 Graphic conventions</i>	Indicates the title of a chapter, section, paragraph, table or figure in this manual or other published reference.
Text in boldface	<b>menu ?, Information</b>	Indicates the title of a section, key or software item
<text>	#<AccountCode>	Editable field

The "Note" sections contain important information relating to the text.

**Note**

The "Attention" prompts indicate that total or partial disregard of the procedure could damage the device or its peripherals.

**ATTENTION!**

# Chapter 1

## GENERAL INFORMATION

### Manufacturer's details 1-1

Manufacturer: INIM Electronics s.r.l.  
 Production plant: Centobuchi, via Dei Lavoratori 10  
 63076 Montepandone (AP), Italy  
 Tel: +39 0735 705007  
 Fax: +39 0735 704912  
 e-mail: info@inim.biz  
 Web: www.inim.biz

The persons authorized by the manufacturer to repair or replace the parts of this system, hold authorization to work on INIM Electronics brand devices only.

### Description of the product and various models 1-2

The SmartLink device described in this manual is a reserve telephone line generator and telephone dialler.

#### DESCRIPTION

If problems occur on the PSTN (linedown conditions, etc.), the SmartLinkAdv will guarantee communications by switching to a GSM provider and allowing any connected devices to operate normally.

#### RESERVE TELEPHONE LINE

When the SmartLinkAdv operates as a simulated line, it tests the PSTN line periodically to check if the communication problems have cleared. If the PSTN line is found to be operating normally and there are no ongoing telephone calls passing through the interface, the system will switch back to the main PSTN line. Otherwise, it will switch back to the PSTN only when all the necessary outgoing calls have been forwarded.

SmartLinkAdv generates a series of operations (e.g. calls, output commands) in relation to internal events (e.g. low battery) or external events (e.g. input status changes, received call, received SMS commands).

#### TELEPHONE DIALLER

- Status control and output actions via SMS messages
- Output control and output actions via calls using the voice menu
- Output actions via Caller ID recognition
- Digital dialler (Ademco 10bps, Ademco 14bps, Franklin 20bps, Radionics 40bps, Scantronic 10bps, Contact-ID, SIA-IP)
- SMS dialler
- Voice dialler
- Open tamper protection
- Jamming detector
- EasyScan (automatic search for the best GSM provider)

#### OTHER FUNCTIONS

**SmartLinkAdv/GP** - GSM and PSTN reserve line generator and telephone dialler **MODELS**

**SmartLinkAdv/G** - GSM reserve line generator and telephone dialler

**SmartLinkAdv/P** - PSTN telephone dialler

Table 1-1: Applications

Models	SmartLinkAdv /P	SmartLinkAdv /G	SmartLinkAdv /GP
Reserve telephone line generator		•	•
On-board voice module with 15 minutes	•		•
Anti-intrusion function	•		•
Dialler over GSM network and PSTN landline and GPRS modem		•	•
Dialler over PSTN landline	•		•
SMS dialler over GSM network		•	•
Manages DTMF commands over GSM network		•	•
Manages DTMF commands over PSTN landline	•		•
Priority channel choice between SM network and PSTN landline		•	•
Fault signalling	•	•	•
Incoming SMS divert		•	•
Actions using Caller ID		•	•
Manages commands via SMS with code or identifier of the sender		•	•
Ring or SMS confirmation for commands receiving via SMS		•	•
Warning calls for each event over GSM network and PSTN landline		•	•
Manages GPRS for remote programming/monitoring		•	•
Manages supervision over GPRS		•	•
Periodic supervision between 2 SmartLinkAdv devices		•	•
Manages SIA-IP and transmits information to alarm receiving centres via the most widely used protocols		•	•
Answerphone with voice menu	•		•
Manages and signals "Roaming" status		•	•
EasyScan function		•	•
Jamming detector function		•	•
SIM card credit enquiry		•	•

EN 50131-1:2006 + A1:2009,  
 EN 50131-10:2014,  
 EN 50136-1:2012,  
 EN 50136-2:2013,  
 EN 50130-4:2011 + A1:2014,  
 EN 50130-5:2011,  
 CEB T014:2013-04 (ed.3)

#### STANDARDS APPLIED

Security rating 3 for SmartLinkAdv/G and SmartLinkAdv/GP models and security rating 2 for SmartLinkAdv/P. **SECURITY RATING**

## Supplied documentation 1-3

- Installation manual (this manual)
- SmartLeague software programming manual

The manuals are regularly supplied with the apparatus and can be downloaded from the "Download" section of our website: [www.inim.biz](http://www.inim.biz).

The installation manual is included in the package. To order further copies contact the offices at INIM Electronics.

# Chapter 2

## DEVICE DESCRIPTION

### Unpacking the device 2-1

The device is packed inside a cardboard box containing:

- The SmartLinkAdv comprises a PCB mounted inside a metal box
- A bag containing the installation kit comprising:
  - Antenna
  - 10 x 3k9 Ohm 1/4W resistors
  - 10 x 6k8 Ohm 1/4W resistors
  - 4 screws to secure the cover to the metal backbox
- Installation manual (this manual)

The installation kit does not include:

- 1.2 A/h battery
- Switching power supply/battery charger
- SIM card

---

These items must be purchased before beginning the installation phase.

---

**Note**

### Accessory items 2-2

The following accessory devices are individually packed and must be ordered separately:

- IPS12015 Switching power supply/battery charger
- TamperNO dislodgement tamper protection
- Remote antenna for indoor use
- High-performance GSM antenna
- High-performance GSM antenna with 3m of cable for indoor use

### Technical description 2-3

The data label is located inside the metal box.

Following are the technical features of the devices and the description of their components:

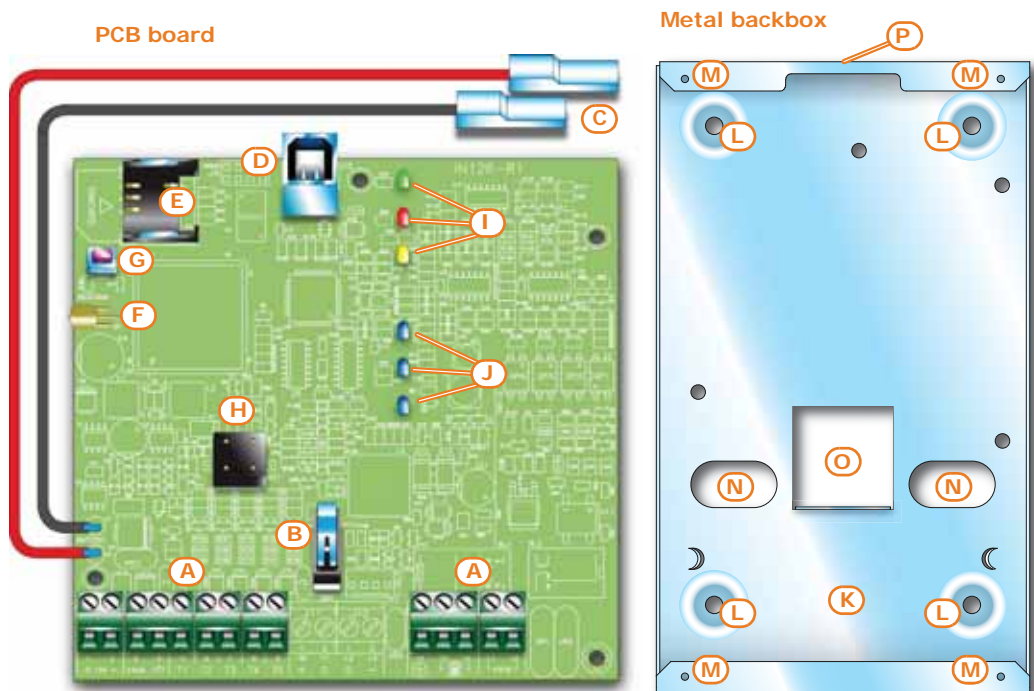

Table 2-1: Description of parts

A	Terminal board
B	Open-tamper microswitch
C	Battery connector
D	USB connector
E	SIM card connector
F	Antenna connector
G	Default-data reset button
H	Buzzer
I	Activity LED
J	GSM signal reception LED

K	Battery housing
L	Wall-mount screw locations
M	Screw holes
N	Cable entries
O	Dislodgement-tamper microswitch location
P	Antenna placement hole

Table 2-2: Terminals on the terminal board



n.	icon/identifier	function
1	+ 14V	Positive power terminal
2	- 14V	Negative power terminal
3	+AUX	12V Ancillary power supply
4		Power supply negative (earth or GND)
5-6-7-8-9	T1-T2-T3-T4-T5	Control panel input terminals: T1, T2, T3, T4 and T5
14		Earth connection
15-16		Internal telephone-line connection
17-18	PSTN	Landline connection

Table 2-3: Technical specifications

Models		SmartLinkAdv/P	SmartLinkAdv/G	SmartLinkAdv/GP
Voltage	Nominal output voltage	13.8 V $\pm$ 10%		
	Functioning range	11 - 16 V		
PCB current-draw during	standby status	40 mA	100 mA	
	during transmission	-	300 mA	
	maximum	70 mA	600 mA	
Maximum current draw of +AUX terminals		400 mA		
Switching power supply		14V 1.05A		
Backup battery		12V, 1.2Ah lead battery with UL94HB flame class or higher		
Inputs		5		
Outputs	total	5		
	Type	150 mA open-collector output		
GSM frequency band		-	850, 900, 1800 and 1900 Mhz (Quad band)	
Number of events recorded		1000		
Operating temperature		from -10°C to + 40°C		
Ambient Class		II		
Dimensions (W x H x D) excluding antenna		134 x 220 x 53 mm		
Dimensions (W x H x D) including antenna		-	134 x 300 x 53 mm	
Weight		890g		

Table 2-4: Technical specifications of the reserve line

Voltage	40Vdc
Loop current	25mA
Dialling tone	425Hz continuous
Engaged tone	200ms 425Hz / 200ms silent
Recognized dialling tone	DTMF
Ring voltage	90Vpp
Ring frequency	25 - 50 Hz (selectable)

## Signalling from device 2-4

The SmartLinkAdv also manages signalling on the LEDs and buzzer as well as signalling events executed over-the-phone, via SMS message, or triggered by output activations.

The SmartLinkAdv is equipped with six signalling LEDs, the activation of which, thanks to light guides, can be seen on the outside of the metal box. **LEDS**

The table shows the meanings of the LEDs when activated:

Table 2-5: LED signalling

LED			Status			
Num.	Colour	Signalling	ON	OFF	Slow flashing	Fast flashing
1	Green	Operating status	Device operating		Device initializing	
2	Red	Fault		No faults present	Flash cycle followed by pause: <ul style="list-style-type: none"> <li>• 1 flash: general battery fault</li> <li>• 2 flashes: telephone line fault</li> <li>• 3 flashes: GSM network trouble</li> <li>• 4 flashes: low credit warning</li> </ul>	
3	Yellow	SmartLinkAdv operating status Communication status	SmartLinkAdv armed	SmartLinkAdv disarmed and there are no ongoing calls	SmartLinkAdv disarmed and one call is ongoing	SmartLinkAdv armed and there is one ongoing call
4	Light blue	GSM reception status	GSM signal quality:		One LED flashing: average signal reception between two of the three predefined levels. All three LEDs flashing: no GSM reception	
5	Light blue		<ul style="list-style-type: none"> <li>• One LED On: poor signal reception</li> <li>• Two LEDs On: average signal reception</li> <li>• Three LEDs On: optimum signal reception</li> </ul>			
6	Light blue					

In the event of the presence of more than one fault, LED 2 will indicate all the faults one at a time.

**Some operations (for example, calls to alarm receiving centres using Contact-ID, SIA-IP, 10 and 20bps protocols) require that at least two light-blue LEDs are ON solid.**

**ATTENTION!**

The SmartLinkAdv provides further LED signalling, in addition to the above-mentioned cases, indicated by the simultaneous lighting of several LEDs:

- During the programming and initializing phases all six LEDs must flash simultaneously.
- SmartLinkAdv is predisposed for the "Easyscan" function and "Easyscan" active function (refer to *paragraph 3-7 Easyscan*): successive activation in cyclic mode of all the LEDs starting from LED 6 to LED 1.
- Incoming SMS: successive activation in non-cyclic mode of one LED at a time starting from LED 1 to LED 6.

The buzzer provides the end-user with audible signalling.

**BUZZER**

The buzzer provides entry time, exit time and command confirmation signals (if programmed). Activation of these signals can be configured during the programming phase.

Table 2-6: Signalling and signal type

Signalling	Signal type
Entry time running	Short pulse cycles
Entry time running	Long pulse cycles
Command carried out	3 short pulses
Command not carried out	5 long pulses

# Chapter 3

## SMARTLINKADV FUNCTIONS

### Telephone line down management 3-1

The devices that are to use the reserve line during PSTN line-down conditions must be connected to terminals 15 and 16.

When the PSTN line is operating properly, terminals 15 and 16 are connected internally to 17 and 18.

If, on the latter, the voltage drops below 3Vdc for 10 seconds, SmartLinkAdv will disconnect from the PSTN line and switch to the auxiliary line. The status of the PSTN line will be checked for restoral every 3 minutes.

The absence of the PSTN line is signalled on the fault LED (red LED) by 2 flashes. The signalling will activate only after the PSTN line has been down for the programmed time.

### Input/Output terminals 3-2

The five terminals 5-9 can be configured individually as:

- Input zone terminal
- Double zone terminal (ZONE DOUBLING)
- Output terminal
- Controlled output terminal (I/O)
- Unused terminal

An electrical input point used for the management/supervision of signals coming from a device. The activation of the signal may cause the SmartLinkAdv to carry out one of the following actions:

- Send an SMS message
- Send a digital protocol message
- Send a voice message
- Command an output
- Change the operating status of the SmartLinkAdv

#### INPUT/ZONE

The outputs are open-collector outputs and allow the transmission of commands to external devices (e.g. switch on lights, open gate, etc.).

The outputs can be activated by the SmartLinkAdv in response to local and remote events (SMS message, DTMF call and Caller ID).

The standby condition of each output can be:

- Open
- Closed

#### OUTPUT

The outputs can be configured as:

- Bistable
- Pulse

This is an output whose status can be controlled (activated/deactivated) and used for other activations.

### CONTROLLED OUTPUT

An electrical input point used for the management/control of signals coming from two devices.

### DOUBLE ZONE

The terminal the zone is connected to must be configured as a "double input zone". Terminals with this configuration allow the system to distinguish between two distinct alarms coming from the two different zones it is connected to.

## Event activations 3-3

The SmartLinkAdv is capable of recognizing specific external signals coming from the PSTN or GSM network or via input terminals T1, T5 or internal signals such as "events".

When such events occur or when they clear (reset/return to default status), the SmartLinkAdv can implement the following activations:

- activate outputs
- generate voice calls
- send digital protocol messages
- send SMS messages

In *Appendix A, Events* you can find the complete list of events generated by the SmartLinkAdv.

## Dialler function 3-4

The digital dialler function generates digital-protocol calls directly to alarm receiving centres.

### DIGITAL

The available protocols are: Ademco 10bps, Ademco 14bps, Franklin 20bps, Radionics 40bps, Scantronic 10bps, Contact-ID, SIA-IP

The SMS dialler function generates outgoing SMS messages. The outgoing SMS messages are sent in response to an event.

### SMS FUNCTION

During the programming phase you can select the SMS message type, which can be automatic, predefined by the SmartLinkAdv or customized by the installer.

The voice-dialler function activates outgoing calls containing recorded voice messages.

### VOICE

During the programming phase you can select the voice messages, which can be either predefined by the SmartLinkAdv or customized by the installer.

**INIM does not guarantee the total availability of all the GSM functions described in this manual, due to the various combinations of GSM service providers, SIM types and telephone models that may be in use.**

## ATTENTION!

## Command and Shortcuts 3-5

A command is a request from the end-user or a device to the SmartLinkAdv to carry out one or more of its functions.

During the programming phase of the SmartLinkAdv you can arrange the commands into shortcuts. A shortcut is a single request that activates a series of successive functions. If necessary, you can define the shortcut parameter, in other words, the object of the shortcut (e.g. define a specific output for functions such as “activate output” shortcuts).

### SHORTCUTS

Table 3-1: Available shortcuts

description	function	parameter	note
<b>Arm/Disarm</b>	Applies a preset scenario	which scenario	Shortcuts are available only when the SmartLinkAdv is programmed as an intrusion control panel
<b>Stop alarms</b>	Deactivates instantly the outputs activated by alarm and tamper events		
<b>Delete memory</b>	Carries out a “Stop alarms” operation and, at the same time, deletes alarm and tamper memories.		
<b>Clear call queue</b>	Cancels the call queue and stops ongoing calls (if any).		
<b>Output activation</b>	Activates one of the programmed outputs	which output	
<b>Output deactivation</b>	Deactivates one of the programmed outputs	which output	
<b>Voice info</b>	Starts playback of the audible message playback that informs the user of the device status		Shortcuts available for codes only
<b>Status enquiry</b>	Activates a device status enquiry; the user will receive one or more SMS messages containing a list of the parameter values relating to the status.		Refer to the default commands described in <i>paragraph 3-6 Remote activation</i>
<b>Credit enquiry</b>	Activates balance enquiries relating to the SIM card of the device; the user will receive an SMS text indicating the remaining credit.		
<b>GPRS Client</b>	Activates the GPRS connection with the SmartLeague software program via SMS		

## Remote activation 3-6

All the functions of the SmartLinkAdv device can be activated from remote locations.

Therefore, it is possible to send commands to the SmartLinkAdv by means of:

- SMS messages
- telephone calls using Caller ID
- telephone calls assisted by a voice guide (“Answerphone” function)

After receiving one of the above-mentioned commands, the SmartLinkAdv will activate the associated actions.

Both commands and their associated actions can be configured through the SmartLeague software program, in the sections relative to the GSM network commands and user codes.

## Commands over the GSM network 3-6-1

Up to 200 actions can be programmed to activate in response to remote GSM commands.

Each of the actions can be triggered by either an SMS command or a Caller ID command or both.

Users who wish to activate a command via SMS text must enter the command details as follows:

```
<xxxxxx> <SMS Text>
```

where:

- <xxxxxx> stands for the user PIN
- a blank space must be keyed in after PIN entry
- <SMS text> is the identification of the command, as programmed via software

### COMMAND VIA SMS MESSAGE

The following commands are predefined at default:

### DEFAULT COMMANDS

- **"CODE"** for the change of the user PIN code via SMS message; the message text format must be:
 

```
<old PIN code> CODE <new PIN code>
```
- **"CREDIT"** for balance enquiries relating to the SIM card of the device; the user will receive an SMS text indicating the remaining credit.
- **"STATUS"** for enquiries relating to the status of the SmartLinkAdv; the user will receive an SMS text indicating:
  - device name and firmware revision
  - GSM network provider
  - GSM signal reception level
  - Presence of the PSTN line
  - list of faults present
  - device tamper status
  - power supply of the circuit
  - armed/disarmed status of the SmartLinkAdv
  - list of zones in alarm status
  - list of terminals in tamper status
  - status of outputs
  - remaining credit as last read
- **"CONNECT"** for the maintenance request; the message text format must be:

```
<xxxxxx> CONNECT <Connection Name> <URL>: <Port>
```

where:

- <xxxxxx> is the installer code PIN, followed by a blank space
- "CONNECT" is the connection command, followed by a space
- <Connection Name> is the description of the connection followed by a space
- <URL>: is the IP address of the server you wish to connect to, followed by ":"
- <Port> is the connection port

The latter two parameters can be omitted if they have already been included in the GPRS section programming fields of the SmartLinkAdv.

A Caller ID command is a command requested over-the-phone by an end-user whose telephone number is present in the configuration of the actions to be carried out following the command. This type of telephone number must be associated with a user code.

The SmartLinkAdv recognizes the Caller ID and activates the programmed actions.

---

The remaining credit control feature is subject to temporary or even permanent unavailability caused by changes in the implementation of the methods used by the GSM/GPRS service provider.

INIM provides device programming functions which may be capable of restoring this feature, by means of manual changes to the respective parameter settings.

---

## INCOMING CALLER ID COMMANDS

### Note

## Answerphone 3-6-2

The “answerphone” function, if enabled by the installer on the PSTN or GSM network line, allows the SmartLinkAdv to answer incoming phone calls. Following is the procedure which activates the programmed action:

1. Call the number of the SIM Card inserted in the SmartLinkAdv or the telephone number of the PSTN line connected to the device.
2. After a programmed number of rings, the SmartLinkAdv will engage the line and play the voice message:  
Type-in code followed by “#”
3. Enter a valid user-code then press “#” on the telephone keypad.
4. The SmartLinkAdv will start a voice message listing the short-cuts associated with the entered code and the corresponding keys on the telephone keypad (voice menu).
5. Activate the required commands by pressing the corresponding keys on the telephone keypad.

## Easyscan 3-7

The “Easyscan” function of the SmartLinkAdv allows the installer to select the best GSM network provider for the SmartLinkAdv installation, in accordance with the signal reception.

This function can be activated exclusively via the SmartLeague software program and does not require a SIM card to be inserted in the SmartLinkAdv.

Once initialized, the SmartLinkAdv scans the GSM signals in the installation zone. When the scan is complete the software will show a list of the operators detected in the area and the reception quality of their signals. This data can be used by the installer to optimize the installation.

## Jamming detector 3-8

The “jamming detector” function allows the SmartLinkAdv to check for the presence of radio frequency and generate the “Jamming” event should the any eventual source detected inhibit the proper operating capacity of the device over the GSM network.

# Chapter 4

## INSTALLATION

### Wall-mounting 4-1

The SmartLinkAdv should be located in a place that is not on view or easily accessible to outsiders.

**Verify that the GSM network signal of the selected provider is adequate.**

**Do not install the device near metal objects.**

**Ensure that there are at least two metres between the device and other electrical devices.**

### ATTENTION!

1. Using the metal backbox (*table 2-1, L*), mark the anchor screw locations on the wall. Be sure not to drill in the vicinity of electrical wiring or plumbing/gas pipes, etc.
2. Insert the screw anchors (recommended size 6mm).
3. Pull the wires through the wire entry.
4. Using the screws, attach the backbox to the wall.
5. Fit the anti-dislodgement bracket (optional):
  - 5.1. Fit the anti-dislodgement bracket into its housing on the back of the control panel (*table 2-1, O*).
  - 5.2. Using screw location, screw the bracket to the wall where the box is mounted.
  - 5.3. Cut off the connector of the anti-dislodgement device and strip the two wires.
  - 5.4. Connect one of the wire to a "T" terminal (*table 2-2, 5-6-7-8-9*, configured as a normally-closed) and the other to the ground terminal (, *table 2-2, 4*).

The cable gland must be flame class rating V-1 or higher.

### Note

### Connecting to the mains power supply 4-2

The SmartLinkAdv must be powered from the mains and connected to a backup battery.

The mains supply requires the use of a power supply and therefore a separate line from the mains box. The line must be protected by a safety-standards compliant circuit breaker (trip switch).

The protective earthing system must be compliant with all safety standards and laws in force.

### MAINS POWER SUPPLY 230VAC 50HZ

**Ensure that the Mains is switched Off during the mains connection phase. Danger of electric shock.**

Connect the power supply (already connected to the mains) to terminals "+ 14 -" of the PCB (*Table 2-2 "Terminals on the terminal board"*), taking care to respect the polarity of the electrical wires.

The power supply will provide power to the SmartLinkAdv, to the devices connected to its outputs and to the backup battery.

The backup-battery connection must be achieved through the connector on the PCB (*table 2-1, C*) and the specific wire (included) which has a faston terminal at each end.

**Ensure that battery polarity is correct:**

- black wire = negative
- red wire = positive

The lead battery is the secondary power source that provides power to SmartLinkAdv and the devices connected to its outputs when the primary power source fails (mains blackout).

**ATTENTION!**

**BACKUP BATTERY**

**ATTENTION!**

## Mounting the antenna

### 4-3

1. Remove the antenna from the bag.
2. Remove the nut and washer that are screwed onto the antenna.
3. Pass the antenna cable through the cable entry on the top of the enclosure into its housing (*table 2-1, P*).
4. Using the nut and washer, secure the antenna in place.
5. Connect the antenna wire to the respective connector on the PCB (*table 2-1, F*).

**STANDARD ANTENNA**

If it necessary to mount the SmartLinkAdv in a part of a building where the GSM reception is weak, it is possible to request an M-ANT remote antenna in replacement of the one regularly supplied.

The remote antenna is equipped with a long cable, a magnetic base for installation in a place inside the building where the GSM network signal is strong, and an ancillary wire for the connection to the PCB board.

1. Remove the antenna and wire from the bag.
2. Remove the nut and washer that are screwed onto the antenna.
3. Pass the antenna cable through the cable entry on the top of the enclosure into its housing (*table 2-1, P*).
4. Screw the cable nut onto the antenna.
5. Mount the magnetic base of the antenna in a place where the GSM network reception is good.
6. Using the ancillary wire, connect the antenna wire to the respective connector on the PCB (*table 2-1, F*).

**REMOTE ANTENNA**

## Telephone connections 4-4

Connect the PSTN line to terminals 17 and 18 (*Table 2-2 "Terminals on the terminal board"*).

---

SmartLinkAdv is protected against eventual lightning strikes.

---

**Note**

Connect the telephone equipment (or other device/apparatus that requires a reserve telephone line) to terminals 15 and 16.

Up to 4 devices can be connected in parallel.

---

**A voltage of up to 100Vdc may be present on terminals 15 and 16 during the ring phase.**

---

**ATTENTION!**

---

In the presence of an ADSL, it is necessary to connect the SmartLinkAdv downstream of the ADSL filter, on the line where the telephone devices are connected (this line is clearly indicated on the filters).

---

**Note**

## Earth connection 4-5

Terminal 14 must be connected to earth and connected equipotentially to terminal 2 (*Table 2-2 "Terminals on the terminal board"*).

---

**This operation is necessary in order to comply with the security requirements of the telecommunications network, and also to protect the device against overload and/or electrical discharge coming from the external telephone line.**

---

**ATTENTION!**

## Inserting the SIM card 4-6

Deactivate the PIN code of the SIM card and insert it into its housing (*table 2-1, E*).

The SIM card must be inserted when the system is Off (not powered).

---

**There is a risk that phone numbers and/or SMS messages contained in the SIM card may be lost when it is inserted into the SmartLinkAdv.**

---

**ATTENTION!**

---

Before choosing the GSM network provider and inserting the SIM card (refer to *paragraph 5-2 Easyscan procedure*), it is advisable to use the Easyscan function from the SmartLeague software program in order to identify the best GSM network signal.

## PC Connection 4-7

For the programming of the SmartLinkAdv, the project and monitoring processes of the system the SmartLinkAdv is connected to requires a connection with a PC equipped with SmartLeague software (refer *paragraph 6-1 Using the SmartLeague software program*).

This connection can be achieved as follows:

- Connection via USB
- Connecting via GPRS

### Connection via USB 4-7-1

The connection with the PC can be achieved through a USB cable inserted into the respective connector on the PCB (*table 2-1, D*).

Once connected to the SmartLinkAdv, the USB device installation driver recognized by the PC provides the SmartLeague software program installation folder, specifically the following folder (for an installation at default):

C:\Program Files\Inim\SmartLeague\drivers\SmartLink\_advanced

### Connecting via GPRS 4-7-2

The connection with the SmartLinkAdv occurs only after a request for teleservice made through an SMS command.

Once the GPRS parameter settings are complete, you will be able to activate the GPRS connection by means of the following procedure:

1. Start the SmartLeague software program and access the "Settings, Application settings" menu section. Select "Connection via GPRS" from the options available in the "Communication type" section, then press **Start**.
2. The **Start** button opens the GPRS connection status section, where you must set the port. The setting must coincide with the "Port" described above.
3. Press the **Connect** button to activate the server.
4. Request teleservice by sending the default SMS message "CONNECT" (refer to *paragraph 3-6-1 Commands over the GSM network*).
5. After the SMS message has been sent, you must wait until the software indicates that the connection has initialized.
6. Once the connection is active, you can carry out the desired upload/download operations via the SmartLeague software program.
7. Once the programming session is complete access the "Settings, Application data, GPRS Connection" section, then select the **Disconnect** button to end the connection.  
If no upload/download operations are carried out for 5 consecutive minutes, the GPRS connection will end automatically.

# Wiring and balancing alarm detectors

## 4-8

The wiring and respective balancing method depend on the type of detector you are installing, and the level of protection you wish to achieve. The detectors can be powered through:

- terminal [+AUX/12V] and [-/negative] present on the PCB
- from any ancillary 12V power source as long as it has a ground reference (GND) in common with the ground reference of the SmartLinkAdv

The resistors used for balancing are:

- 3K90hm 1/4W
- 6K80hm 1/4W

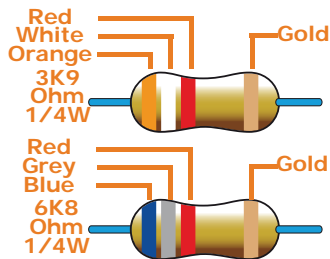

The following table indicates the protection level of each detector type and the balancing options provided:

Table 4-1: Protection level

BALANCING	N.O.	N.C.	Single	Double	Double zone	Double zone with EOL
<b>Infrared or Double technology</b>	very low	low	medium (*)	high	medium	high
<b>Magnetic contact</b>	very low	low	medium		medium	high

(\*) The level of protection of Single balanced mode is as secure as Double balanced mode if the tamper contact of the detector is connected to a balanced zone on the SmartLinkAdv.

## N.C./N.O. Balancing 4-8-1

For N.C. (normally closed) and N.O. (normally open), it is possible to detect two distinct zone conditions:

- standby
- alarm

For each of these the SmartLinkAdv reads different values of the equivalent resistance on the terminal, shown below in Ohm:

Ohm	N.C.	N.O.
$> 2 \times 3900 + 6800$	alarm	standby
$> 2 \times 3900 + 6800$	alarm	standby
$3900 + 6800$	alarm	alarm
$2 \times 3900$	alarm	alarm
3900	standby	alarm
0	standby	alarm

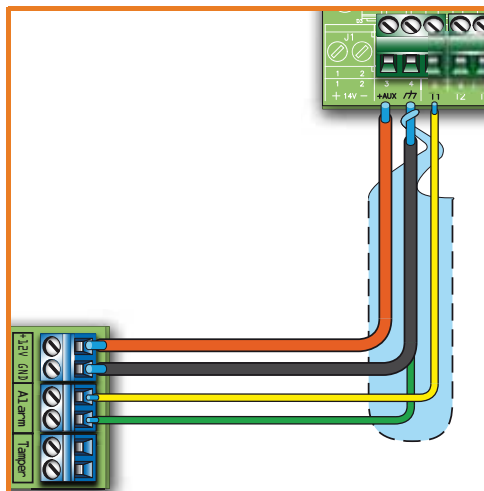

## Single balancing 4-8-2

Single zones can discriminate 3 conditions on the entire terminal:

- standby
- alarm
- tamper (short-circuit)

For each of these the SmartLinkAdv reads different values of the equivalent resistance on the terminal, shown below in Ohm:

Ohm	Zone
> 6800	alarm
6800	standby
0	tamper

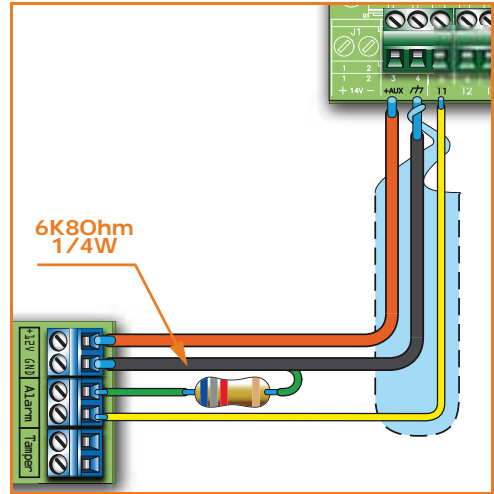

## Double balancing 4-8-3

Double balancing discriminates 4 distinct conditions on the zone terminal:

- standby
- alarm
- tamper (short-circuit)
- tamper (wire cutting)

For each of these the SmartLinkAdv reads different values of the equivalent resistance on the terminal, shown below in Ohm:

Ohm	Zone
> 6800	tamper (wire cutting)
6800	alarm
6800 / 2	standby
0	tamper (short-circuit)

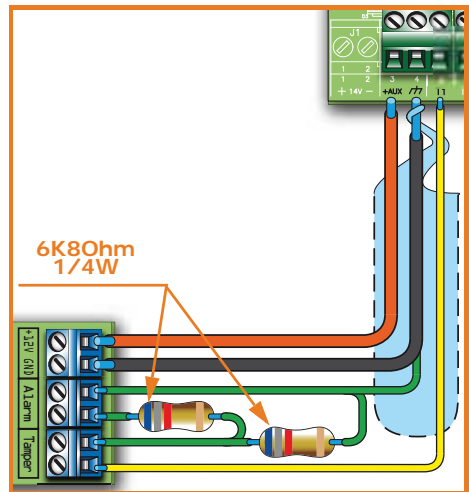

## Double-Zone balancing 4-8-4

Double zones without EOL resistor can discriminate 5 conditions on the entire terminal:

- standby on both zones
- alarm on zone 1 and standby on zone 2
- alarm on zone 2 and standby on zone 1
- alarm on both zones
- tamper (wire cutting)

For each of these the SmartLinkAdv reads different values of the equivalent resistance on the terminal, shown below in Ohm:

Ohm	Zone 1	Zone 2 (double)
$> 3900 + 6800$	tamper	
$3900 + 6800$	alarm	alarm
6800	standby	alarm
3900	alarm	standby
0	standby	standby

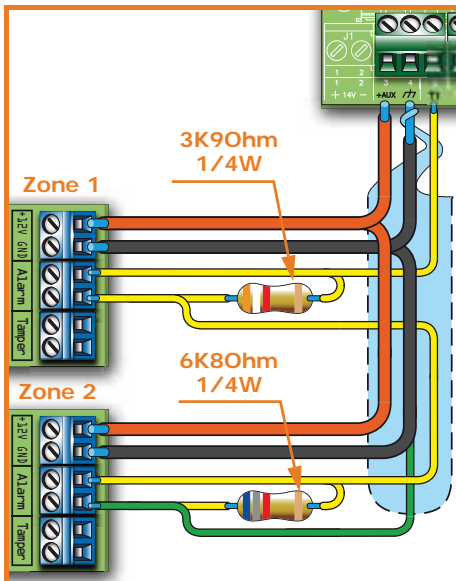

## Double balanced zone with EOL 4-8-5

Double zones with EOL resistors can discriminate 6 conditions on the terminal:

- standby on both zones
- alarm on zone 1 and standby on zone 2
- alarm on zone 2 and standby on zone 1
- alarm on both zones
- tamper (wire cutting)
- tamper (short-circuit)

For each of these the SmartLinkAdv reads different values of the equivalent resistance on the terminal, shown below in Ohm:

Ohm	Zone 1	Zone 2 (double)
$> 2 \times 3900 + 6800$	tamper (wire cutting)	
$> 2 \times 3900 + 6800$	alarm	alarm
$3900 + 6800$	standby	alarm
$2 \times 3900$	alarm	standby
3900	standby	standby
0	tamper (short-circuit)	

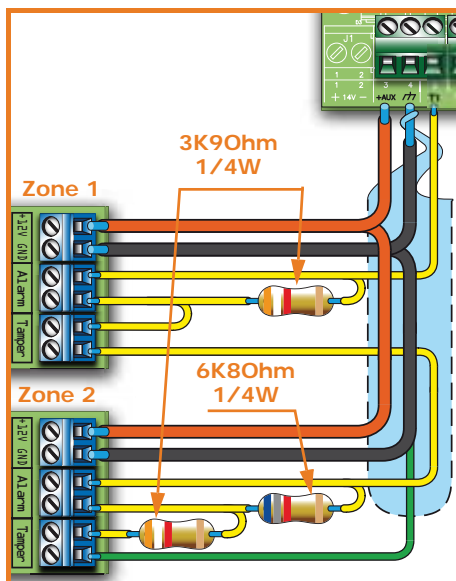

## Connecting the outputs 4-9

The SmartLinkAdv can activate one (or more) outputs in response to a recognized event.

All the outputs are open-collector outputs capable of sinking a maximum current of 150mA.

The wiring diagram below illustrates a series of typical connections for the activation of a load when a Normally Open output closes to GND.

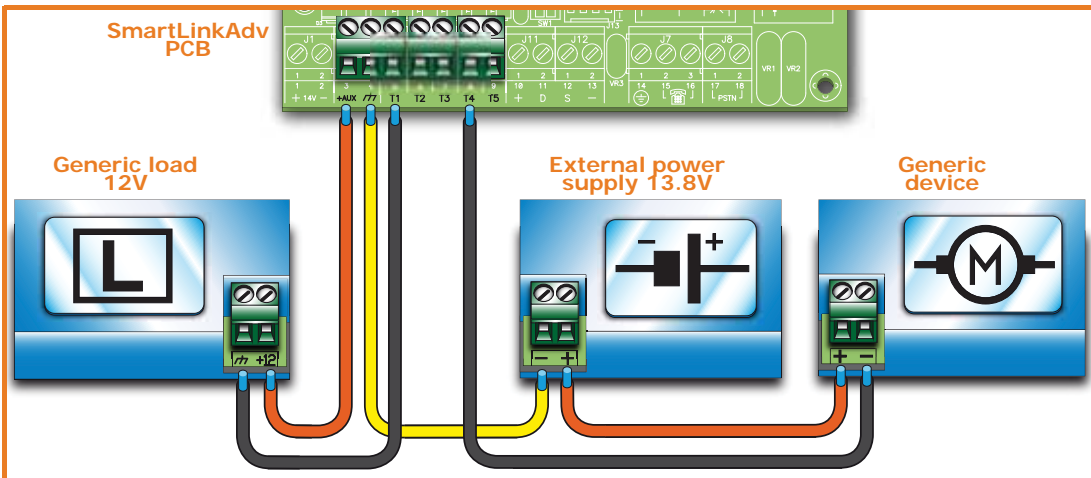

# Chapter 5

## FIRST POWER UP

In order to allow the system to perform an accurate auto-enrolling operation on "First power-up", work carefully through the following steps.

**When completing the wiring ensure that the power supply sources (mains 230V a.c. and backup battery) to the SmartLinkAdv and its connected devices are disconnected.**

### ATTENTION!

1. Mount the SmartLinkAdv to the wall.
2. Connect the antenna.
3. Complete the wiring and balancing of the system detectors.
4. Connect the outputs to the terminals.
5. Connect the telephone line.
6. Connect the primary power source (230V a.c.).
7. Connect the backup battery.  
Start the initializing phase.
8. Start the Easyscan function.
9. Remove all power from the system.
10. Insert the SIM card.
11. Restore power to the system.

## Initializing phase 5-1

On powerup, the device carries out a self-diagnosis phase. During this phase all the LEDs will flash.

If no anomalies are detected during the self-diagnosis phase, the device will initialize the normal operating phase after approximately 30 seconds.

Initialization of the normal operating phase is signalled by the deactivation of all the LEDs except the green LED which will be On solid. If, however, anomalies are detected the LEDs will continue flashing.

## Easyscan procedure 5-2

During the installation phase of the SmartLinkAdv and first powerup, the manufacturer strongly recommends the use of the "Easyscan" function for the selection of the best GSM provider.

This function can be activated exclusively through the SmartLeague software program, therefore, you must refer to the respective manual for the descriptions of the parameters involved.

The results obtained by the "Easyscan" regarding the GSM signals should not be considered constant throughout time, as they are subject to changes relating to the GSM service.

Therefore, you should carry out the Easyscan operation at regular intervals or, at least, when the system is undergoing maintenance.

## Note

Following is the procedure of the Easyscan function:

1. Powerup the SmartLinkAdv without the SIM card inside.
2. The SmartLinkAdv will initialize (*paragraph 5-1 Initializing phase*) and then predispose itself for the Easyscan function for 40 seconds; this period is indicated by blinking on the LED indicated in *paragraph 2-4 Signalling from device*.  
It is necessary to connect the SmartLinkAdv to a PC while this time is running, otherwise, once the 40 seconds expires, the SmartLinkAdv will reinitialize and restart the Easyscan phase. This procedure is cyclical.
3. Connecting the SmartLinkAdv to a PC (*paragraph 4-7 PC Connection*).
4. Start the SmartLeague software program and open "SmartLink Advanced" solution.
5. Go to the "Monitoring, Easyscan".
6. Click on the **Connect SmartLink** button to start the connection with the GSM module.  
Once the connection is made, the normal software functions (Programming functions) will be inhibited.
7. Click on the **Start Easyscan** button to start the scanning process.  
The software application will list, in two sections, the GSM network providers in accordance with the detected signal reception.
8. Click on the **Disconnect SmartLink** button to interrupt the scanning operation.  
You can utilize this scanning method as often as required.
9. Disconnect your PC.
10. Remove all power from the SmartLinkAdv and insert the SIM card into its housing (*table 2-1, E*).

If no SIM card is inserted, the SmartLinkAdv will be unable to function properly and will continue to implement the phases described at point 2.

## Note

# Chapter 6

## PROJECT DEVELOPMENT AND PROGRAMMING

The SmartLinkAdv system was designed to allow programming via PC. All the functions relating to programming and the project are accessible through the software program. You will need:

- a computer which can be connected to the already-installed SmartLinkAdv.
- The SmartLeague software program

### Using the SmartLeague software program **6-1**

The SmartLeague software program resides on the computer of the installer company and allows the preparation of the larger part of the SmartLinkAdv parameters without actually being connected to the device.

The connection is required when uploading data (writing on the SmartLinkAdv) or downloading data (reading from the SmartLinkAdv). The type of connection depends on the means used (refer to *paragraph 4-7 PC Connection*).

The programming parameters of an installation constitute the "solution". The solution can be saved to the memory of the SmartLeague software program, either for future use or as a "model" for other installations.

The homepage of the SmartLeague software program is common to all the programmable devices and is always active, even during the programming session, in the form of a template:

Table 6-1: SmartLeague software program - homepage

A	Open solutions bar	
B	List of recent solutions - which will allow you create new solutions or open existing solutions	
C	Documentation installed on the computer.	
D	Area dedicated to help and service via Internet. It is possible to consult FAQ page, make enquiries and suggestions via e-mail.	
E	<p>Access to the area reserved for registered users of the INIM website.</p> <p>After typing in a Username and Password, you can access the updated versions of the software program, firmware, technical documentation and service.</p>	

## Using the software program 6-2

Each project, from the most uncomplicated to the most complex of systems, is represented by a solution, which contains the programming parameters and installation structure.

A solution is dedicated to a specific type of apparatus and has its own programming interface. You can work on several solutions simultaneously, even if they involve different types of apparatus. Each solution has a template, located next to the "Homepage", which can be viewed at all times. In this way it is possible to compare different solutions and even keep two solutions open, one real and one for test purposes (in order to verify the effects of programming).

When a solution opens, the SmartLeague software program presents the following interface:

### SOLUTIONS

Table 6-2: SmartLeague - solutions

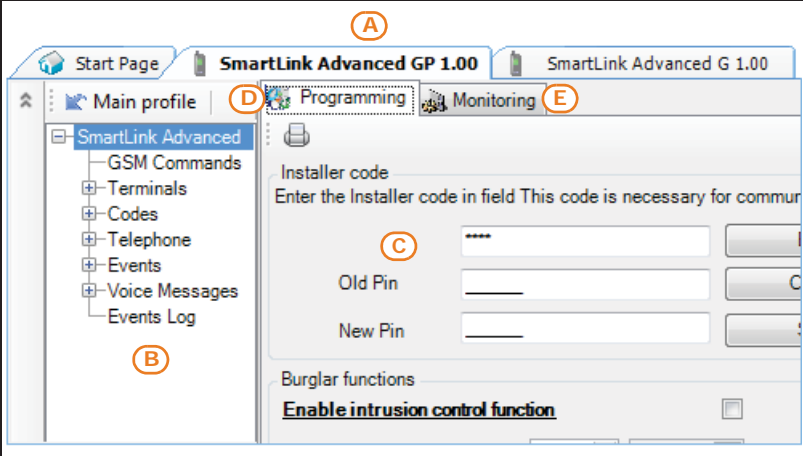

A	The freshly opened template remains in the forefront whilst the other open template and the Homepage remain in the background.	
B	Installation tree structure.	
C	Section in question.	
D	Programming template of the component to be programmed (selected from the tree structure).	
E	Monitoring board for real-time monitoring of the entire system.	

A solution can be created or changed even without being connected to the apparatus. For example, you can arrange the project of an installation or set the options/parameters at your office and download the settings to the system at a later time.

In this case, you must program:

- the installer code PIN by selecting “SmartLinkAdvanced System” from the tree structure on the left and entering the code in the “Programming - Installer Code” section on the right.
- Type of connection, in the “Settings – Application data” section of the menu. For the connection specifications refer to *paragraph 4-7 PC Connection*.

The SmartLeague software program provides buttons (in the top-left corner of the tool bar) for the transfer of the ongoing project/programming data:

-  for download operations
-  for upload operations

These buttons will upload/download all the system data (including any ongoing programming). Whereas, if you are working on a message programming section, these buttons will upload/download only the data on the open template.

## DATA TRANSFER

## Programming via the software

## 6-3

The SmartLinkAdv can be programmed exclusively through the SmartLeague software program.

1. Go to the “Recent solutions” and create a new solution or open an existing one or import the data of a real system by clicking on the  key for the reading of the data.

2. Select the part of the system you wish to program from the tree menu on the left.
3. Set the parameters in the “Programming” section on the right.
4. Write the data on the SmartLinkAdv by clicking on the  key.

During data upload/download operations:

- All outputs will be forced to standby status.
- None of the events recognized by the SmartLinkAdv will activate outputs or be sent to the call queue or recorded in the events log.

SmartLinkAdv provides the following default access codes:

- Installer code: 999999
- User code 1: 000001

## DEFAULT ACCESS CODES

This manual is limited solely to instructions regarding navigation through the software and where to find the various parameters. For full instructions regarding the complete programming process refer to the SmartLeague Installation and Configuration manual, supplied with the software.

## Reset default settings 6-4

In order to reset default programming on the SmartLinkAdv simply work through the following steps:

1. Remove all power from the SmartLinkAdv.
2. Press and hold the reset button (refer to *table 2-1, G*).
3. Hold down the reset button and restore power to the SmartLinkAdv.
4. Wait 5 seconds.
5. Release the button.  
The SmartLinkAdv will restart with the factory default settings.

## Maintenance and monitoring 6-5

The maintenance procedures and their regularity are to be decided by the installer company.

The system maintenance phase requires the use of the SmartLeague software program.

Programmed parameters, which are saved as solutions, can be used as “models” for other installations as well as for successive maintenance operations.

## SOLUTIONS

During the maintenance phase it is possible to read the programming parameters of the SmartLinkAdv, compare them with those already saved in a solution and, then, change and write them on the apparatus.

SmartLeague provides a section where, prior to a direct connection with the SmartLinkAdv (refer to *paragraph 4-7 PC Connection*), it is possible to carry out real-time monitoring on the entire system.

You can reach this section through the "Monitoring" template which is next to the "Programming" template, or by selecting "Control panel, Monitoring" options.

The section provides two sub-sections which can be opened by clicking on the header label:

- "System monitoring" - for real-time monitoring of the system
- "Easyscan" - for easy scanning of GSM network signal reception

Refer to the SmartLeague software program manual for the descriptions of the sections and the parameters being viewed.

The manufacturer strongly advises that the following procedures are carried regularly:

- Clean the SmartLinkAdv.
- Check there are no inappropriate objects inside the box.
- Check the functionality of the LEDs.
- Check the battery efficiency and, if necessary, replace it.
- Check the integrity of the wires and connections.
- Carry out maintenance on the connected devices.

## MONITORING

# Chapter 7

## EN50136 COMPLIANCE

SmartLinkAdv series devices are EN 50136-1 and EN 50136-2 compliant.

The SmartLeague software program provides preset programming parameters which guarantee 50136-2 standard compliance.

To activate these preset parameters automatically select "Programming, EN50136-2 standard compatibility" of the SmartLinkAdvanced system.

The default programming of the SmartLinkAdv has:

**DEFAULT**

- Option "EN50136-2 standard compatibility" enabled
- Installer code: 999999
- User code 1: 000001

## ATS Categories 7-1

The SmartLinkAdv series devices constitute an SPT (Supervised Premises Transceiver) which can be used to create an ATS (Alarm Transmission System) in accordance with the definitions in standards EN 50136-1 and EN 50136-2.

Table 7-1: Maximum ATS categories ATS achievable

SPT Model	SPT primary network interface	ATS categories	
		Single Path (SP)	Dual Path (DP)
SmartLinkAdv/P	PSTN	2	/
SmartLinkAdv/G	GSM/GPRS	6	/
SmartLinkAdv/GP	PSTN	2	2
	GSM/GPRS	6	

Table 7-2: ATS Parameters

ATS Categories		Transmission time		Time relation	Replacement security	Information security	Operating mode
		Classification	Maximum values				
Single Path	2	D2 (60s)	M2 (120s)	T2 (25h)	S0	I0	Pass-through
	6	D4 (10s)	M4 (20s)	T6 (20s)	S2	I3	
Dual Path	2	D3 (20s)	M3 (60s)	T3a (30min)	S0	I0	
	4	D4 (10s)	M4 (20s)	T5 (90s)	S2	I3	

If the SmartLinkAdv is used as an SPT (Supervised Premises Transceiver) for an ATS (Alarm Transmission System), it must be powered by the AS (Alarm System) and not by an IPS12015 power supply which is not allowed.

**Note**

## Access Levels 7-2

The standard defines the following access levels to the device and distinct limitations of use of the system:

- **Level 1** - access by any person (e.g. passer-by)
- **Level 2** - user access
- **Level 3** - installer or maintenance operator access (authorized by user - level 2)
- **Level 4** - manufacturer access

### Access to level 3 7-2-1

For compliance with standard EN50136-2:2013, an installer or maintenance person may operate the system with access level 3 only with the authorization of a system user with access level 2.

The procedure to access level 3 is as follows:

1. Disarm the alarm control panel (CIE), if present and connected to the SmartLinkAdv.
2. Disable the 24h tamper option of the control panel.
3. Open the SmartLinkAdv.
4. Using the programming cable, connect the PC.
5. Start the SmartLeague software program and open the solution relating to the system to be accessed.
6. Select "SmartLinkAdvanced System" from the tree structure, then go to the "Installer Code" section under "Programming".
7. Allow the installer to enter the installer code then press **Enroll**.
8. Allow the user to enter the user code, then press **OK**.

At this point the installer has registered installer access and can work on the device programming parameters.

## Connection with alarm control panel (Control and Indicating Equipment) 7-3

If the SmartLinkAdv is being used as an SPT (Supervised Premises Transceiver) for an ATS (Alarm Transmission System), the default configuration of the terminals must be as illustrated in this paragraph and must not be changed.

With the exception of what is written in this paragraph, the configurations shown in paragraphs 4-8 and 4-9 are for applications in which the SmartLinkAdv is not used as an SPT for an ATS.

Terminal "T1" must manage "Intrusion Alarm" and "Tamper Alarm" T1 signals coming from two CIE outputs.

Therefore, it is necessary to set up a double-zone balance connection with EOL (refer to *paragraph 4-8-5 Double balanced zone with EOL*) and program terminal T1 as a double zone with the following zone descriptions:

- Terminal 01: "Intrusion"
- Terminal 01D: "Tamper"

Terminal "T2" must manage "Hold-up alarm" and "Fault" signals coming from another two CIE outputs. **T2**

Therefore, it is necessary to set up a double-zone balance connection with EOL (refer to *paragraph 4-8-5 Double balanced zone with EOL*) and program terminal T2 as a double zone with the following zone descriptions:

- Terminal O2: "Hold-up"
- Terminal O2D: "Fault"

Terminal "T3" must be connected to the dislodgement-detection device on the control panel (TamperNO) which in turn must be connected to a CIE input with normally-closed balance (refer to *paragraph 4-8-1 N.C./N.O. Balancing*). **T3**

This terminal must be configured as an output associated with the SmartLinkAdv "open-panel tamper" event.

In this way, dislodgement or open tamper on the SmartLinkAdv will generate an "SPT Tamper" event in the control panel.

Terminal "T4" must be connected to a CIE input with normally-open balance (refer to *paragraph 4-8-1 N.C./N.O. Balancing*). **T4**

This terminal must be configured as:

- normally open output
- monostable with 5 second monostable time
- associated with "Unsuccessful call over PSTN" and "Unsuccessful call over GSM" events

Terminal "T5" must be connected to a CIE input with normally-closed balance (refer to *paragraph 4-8-1 N.C./N.O. Balancing*). **T5**

This terminal must be configured as:

- normally-closed output
- associated with "GSM Fault" and "PSTN line Fault" events

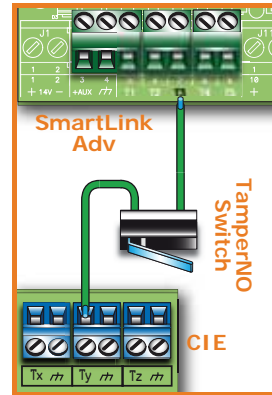

# Appendix A

## EVENTS

An event is a condition recognized by the SmartLinkAdv; each event is characterized by an activation (when an event occurs) and a restoral (when the event ends).

The following table shows the events the control panel recognizes, the number of events for each type, the trigger and restoral method of each event and whether the event is a pulse event (pulse events restore automatically soon after activation).

Table 7-3: Event type

Name	Occurs when...	Restores when ...	Number of events	Pulse events
<b>Zone alarm</b>	A zone generates an alarm	A zone restores	One event for each zone	no
<b>Terminal tamper</b>	A terminal detects tamper (short-circuit or wire cutting)	A terminal restores	One event for each terminal	no
<b>Generic alarm</b>	At least one zone is generating an alarm	All the zones have reset	1	no
<b>Real-time zone</b>	The electrical status of a zone switches from standby to alarm	The electrical status of a zone switches from alarm to standby	One event for each zone	no
	The event is independent of the zone type and the armed/disarmed status.			
<b>Not ready to arm</b>	A zone is not in standby status	All the zones are in standby status.	1	no
<b>Away arming request</b>	A request is made to arm in Away mode	A request is made to disarm the partition	1	Yes
<b>Stay arming request</b>	A request is made to arm in Stay or in Instant mode	A request is made to disarm the partition	1	Yes
<b>Arming effective</b>	SmartLinkAdv is effectively armed in Away mode	SmartLinkAdv is effectively disarmed	1	no
<b>Stay arming effective</b>	SmartLinkAdv is effectively armed in Stay or Instant mode	SmartLinkAdv is effectively disarmed	1	no
<b>Memory reset</b>	Memory reset is requested		1	Yes
<b>Exit time</b>	The exit time is running	The exit time expires	1	no
<b>Entry time</b>	The entry time is running	The entry time expires	1	no
<b>Valid user-code recognized</b>	A PIN entered at a keypad is recognized as valid		One event for each code	Yes
<b>Open-panel tamper</b>	The SmartLinkAdv frontplate is removed	The SmartLinkAdv frontplate is closed	1	no
<b>Low battery</b>	The backup-battery voltage is below 10.7V	The backup-battery voltage is over 11.74V	1	no
<b>Battery fault</b>	The backup battery is low	The backup battery is charged	1	no
<b>Battery not connected</b>	Battery not detected or disconnected	Battery connected	1	no

Table 7-3: Event type

Name	Occurs when...	Restores when ...	Number of events	Pulse events
<b>Deep discharge shutdown</b>	Battery electrically disconnected due to deep discharge	Battery connected	1	no
<b>Mains failure</b>	The primary 230V a.c. power source is not present (blackout)	The primary 230V a.c. power source restores	1	no
<b>Invalid code</b>	An invalid code is entered		1	Yes
<b>GSM Fault</b>	Ongoing trouble on the GSM module.	All faults	1	no
<b>Telephone line down</b>	The land line is not working	The land line restores	1	no
<b>Periodic event</b>	The Periodic Event occurs		3	Yes
<b>Reset from the control panel</b>	SmartLinkAdv restarts The system clock may be wrong or not working properly.		1	Yes
<b>Call queue full</b>	There are no more slots left in the outgoing call queue		1	Yes
<b>Successful call</b>	The call is answered		1	Yes
<b>Input undergoing programming</b>	Access to system programming has occurred	Programming session has ended	1	no
<b>Ongoing call</b>	A call is sent	A call ends	1	no
<b>SMS message not delivered</b>	Failure to send an SMS message through the GSM module has occurred		1	Yes
<b>Output fault</b>	An output fails to switch status as commanded		1	Yes
<b>Low credit</b>	The credit left on the SIM card is below the minimum credit threshold.	The remaining credit is above the minimum credit threshold.	1	no
<b>Unsuccessful call over PSTN</b>	The call sent via PSTN has not been received		1	Yes
<b>Unsuccessful call over GSM</b>	The call sent via GSM has not been received		1	Yes
<b>First ring</b>	An incoming call via PSTN or GSM network	The call is answered or terminated	1	no
<b>Roaming active</b>	The GSM provider that the SmartLinkAdv is connected to is different from the SIM card provider	The GSM provider that the SmartLinkAdv is connected to is the SIM card provider	1	no
<b>Jamming</b>	Jamming detected on the GSM network	Jamming no longer detected on the GSM network	1	no
<b>Supervision failed</b>	The verification of the presence of a remote device (supervision) has failed	Contact with the desired remote device achieved	1	no

# Appendix B

## DECLARATION OF CONFORMITY

**Deutsch:** Hiermit erklärt INIM Electronics s.r.l., dass sich das Gerät SmartLinkAdv in Übereinstimmung mit den grundlegenden Anforderungen und den übrigen einschlägigen Bestimmungen der Richtlinie 1999/5/EG befindet.

**Български:** С настоящето INIM Electronics s.r.l. декларира, че SmartLinkAdv отговаря на съществените изисквания и другите приложими изисквания на Директива 1999/5/EC.

**Ελληνικά:** Ο εξοπλισμός αυτός συμμορφώνεται με την Ευρωπαϊκή Οδηγία 1999/5/EK

**Español:** Por la presente, el INIM Electronics s.r.l declara que este "producto" cumple con la requisitos esenciales y otras disposiciones relevantes de la Directiva 1999/5/CE.

**Français:** Par la présente, INIM Electronics s.r.l. déclare que l'appareil SmartLinkAdv est conforme aux exigences essentielles et aux autres dispositions pertinentes de la directive 1999/5/CE.

**Dansk:** Undertegnede INIM Electronics s.r.l. erklærer herved, at følgende udstyr SmartLinkAdv overholder de væsentlige krav og øvrige relevante krav i direktiv 1999/5/EF.

**Magyar:** Ez a berendezés megfelel az európai 1999/5/EC irányelvnek.

**Malti:** Hawnhekk, INIM Electronics s.r.l., jiddikjara li dan SmartLinkAdv jikkonforma mal-htigijiet essenzjali u ma provvedimenti oħrajn rilevanti li hemm fi d-Dirrettiva 1999/5/EC.

**Isiensi:** Hér með lýsir INIM Electronics yfi r því að SmartLinkAdv er í samræmi við grunnkröfur og aðrar kröfur, sem gerðar eru í tilskipun 1999/5/EC.

**Italiano:** Con la presente, INIM Electronics s.r.l. dichiara che questo SmartLinkAdv è con-forme ai requisiti essenziali ed alle altre disposizioni pertinenti stabilite dalla direttiva 1999/5/CE.

**Lietuvių:** Šiuo INIM Electronics s.r.l. deklaruoja, kad šis SmartLinkAdv atitinka esminius reikalavimus ir kitas 1999/5/EB Direktyvos nuostatas.

**English:** Hereby, INIM Electronics s.r.l., declares that this SmartLinkAdv is in compliance with the essential requirements and other relevant provisions of Directive 1999/5/EC.

**Nederlands:** Hierbij verklaart INIM Electronics s.r.l. dat het toestel SmartLinkAdv in overeenstemming is met de essentiële eisen en de andere relevante bepalingen van richtlijn 1999/5/EG.

**Norsk:** INIM Electronics s.r.l. erklærer herved at utstyret SmartLinkAdv er i samsvar med de grunnleggende krav og øvrige relevante krav i direktiv 1999/5/EF.

**Polski:** Niniejszym INIM Electronics s.r.l. deklaruje że SmartLinkAdv jest zgodny z zasadniczymi wymaganiami i innymi właściwymi postanowieniami Dyrektywy 1999/5/EC.

**Português:** Eu, INIM Electronics s.r.l., declaro que o SmartLinkAdv cumpre os requisitos essenciais e outras provisões relevantes da Directiva 1999/5/EC.

**Româna:** Prin prezenta, INIM Electronics s.r.l., declară că aparatul SmartLinkAdv este în conformitate cu cerințele esențiale și cu alte prevederi pertinente ale Directivei 1999/5/CE.

**Svenska:** Denna utrustning är i överensstämmelse med de väsentliga kraven och andra relevanta bestämmelser i Direktiv Försäkran om över 1999/5/EC.

**Slovenski:** INIM Electronics s.r.l. izjavlja, da je ta SmartLinkAdv v skladu z bistvenimi zahtevami in drugimi relevantnimi določili direktive 1999/5/ES.

Declarations of Performance, Declarations of Conformity and Certificates concerning to INIM Electronics S.r.l. products may be downloaded free of charge from the web address [www.inim.biz](http://www.inim.biz), getting access to Extended Access and then selecting "Certifications" or requested to the e-mail address [info@inim.biz](mailto:info@inim.biz) or requested by ordinary mail.

## Notes

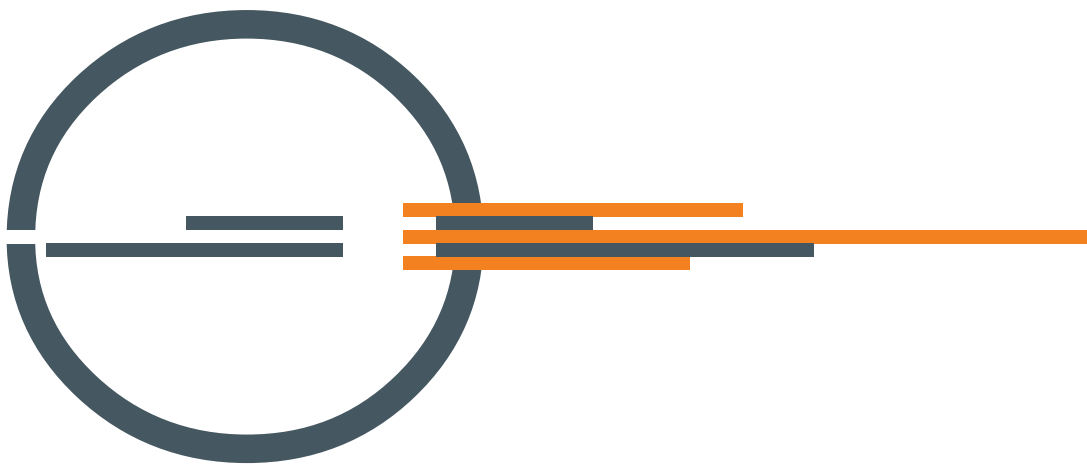

ISO 9001 Quality Management  
certified by BSI with certificate number FM530352

Centobuchi, via Dei Lavoratori 10  
63076 Montepandone (AP) ITALY  
Tel. +39 0735 705007 \_ Fax +39 0735 704912

info@inim.biz \_ [www.inim.biz](http://www.inim.biz)



DCMIINEOSLINKA-170-20180115