

# D-TECT X 50 MKIII

GJD450 50m Wireless Detector



## D-Tect X MKIII Wireless Detector

GJD450 Battery Powered Quad PIR

### Package contents

#### Package Contains:

- 1 x D-Tect X MKIII Wireless Detector
- 1 x Drilling template for fixing holes
- 3 x 31.75mm wall plugs
- 3 x 31.75mm screws
- 2 x Additional sliding curtains
- 2 x Tamper feet
- 1 x Installation manual
- 1 x Self-adhesive lens mask
- 1 x Opening tool
- 1 x Tamper cup

### Introduction

The D-Tect X MKIII Wireless Detector is a battery powered outdoor motion detector that uses two independent passive infrared detectors, both of which must trigger to cause the detector to signal an alarm. Utilising quad PIR technology, the D-Tect X MKIII Wireless PIR delivers precise, reliable presence detection.

The detector is a battery powered device with an integral 868 MHz transmitter to communicate with GJD D-Tect X Receivers / Expanders.

Each D-Tect X 50 MKIII detector transmits radio signals to the receiver and has over 16.7 million individual codes. The receiver only responds to the transmissions of the detector that has been linked to the channel that identifies it. The receiver can only analyse this information after the individual codes have been transferred via the secure wire code learning link.

### Quick Installation

1. Fit the 2 x CR123 3 volt batteries observing the correct polarity. The red LED will flash.
2. Link the detector on to the receiver, using instructions in the 'Code Learning' section.
3. Mount the detector following the instructions given later in this sheet.
4. Wait approximately 2 to 3 minutes to allow the detector to settle.
5. Press the programming button once to activate walk test mode. The detection LED is now enabled for 5 minutes.

**Note: The front cover must be fitted when walk testing.**

The default settings are:

- Range: 50 metres with 15 minute supervision timer
- Pulse count: 1
- Lux level 5
- Timer 5 seconds

### Batteries

Only use CR123 3 V Lithium batteries.

Observe correct polarity when fitting.

### Battery safety information

- Do not put in a fire
- Do not heat
- Do not charge
- Do not short circuit
- Do not disassemble
- Only fit batteries of the same type and voltage

To preserve battery life the detector has a 2 minute sleep timer after a detection. This is reduced to 6 seconds during walk test.

### Mounting The Unit

During installation, protect the electronics against water, as trapped moisture can affect or damage the unit.

1. Drill the wall to accept the two fixing screws and the tamper cup if used. See Figure 1. A hole-drilling template is provided.

**Note: We recommend using the tamper cup on uneven wall surfaces.**

2. Remove the cover assembly by loosening the locking screw. The cover hinges from the top and lifts out of the location slot.
3. Screw the base to the wall ensuring that the tamper pin is correctly located. To aid installation, two alternative length tamper feet are provided.
4. Fit two CR123 3 volt batteries.

**Note: Observe correct polarity**

5. When the detector is aligned, connected and programmed to suit the installation, replace and secure the front cover.

### Supervision Timer

The detector has 2 selectable supervision timer settings of 2 minutes or 15 minutes. This can be changed in the detection range programming option. The first three ranges of 30, 40 and 50 have a 15 minute supervision timer and the second ranges of 30, 40 and 50 have a 2 minute supervision timer.

The 15 minute supervision timer will give longer battery life to the detector. For existing D-Tect X Receivers and Expanders the 2 minute supervision timer will need to be selected if the supervision output on the receiver is being monitored. Receivers and Expanders with a '15 minute supervision' label can use the 15 minute supervision timer setting.

### Multibeam Alignment & Masking

The PIR circuitry detects changes in heat and movement in the beam pattern; therefore items such as trees, shrubs, ponds, boiler flues, air conditioning units and animals should be considered when positioning the detector.

**Note: The PIR sensor is more sensitive to movement across the beams and less sensitive to movement directly towards or away from the beams.**

When mounted at heights above 3 metres there could be a significant reduction in the range of detection and the target will have to move a greater distance within the field of view before an alarm is generated.

## Programming

The user can individually program a number of configurable settings, as illustrated in the programming chart below using the program button and LED shown in Figure 4.

The factory default settings are set to suit the most popular applications but can be changed to suit individual requirements, either before installation or on-site. Once changes have been made they are stored in a non-volatile memory.

The default factory settings for the D-Tect X MKIII detector are as follows:

Range	50 metres (15 minute supervision)
Pulse Count	1
Lux	5
Timer (seconds)	5

To change factory default settings, proceed as follows:

1. Press the 'Program Button' the required number of times to access the setting/mode that needs changing and a red LED will illuminate (see following information and programming chart)

<b>Once</b> -	transfers code
<b>Twice</b> -	sets detector range in metres
<b>Three times</b> -	sets the pulse count
<b>Four times</b> -	adjusts LUX level
<b>Five times</b> -	sets alarm activation time in seconds
<b>Six times</b> -	shows existing settings
<b>Seven times</b> -	resets detector to factory settings
<b>Eight times &amp; hold down</b> -	starts RF continuity test
<b>Nine times &amp; hold down</b> -	generates new random communication code

### PROGRAMMING CHART

Setting	1	2	3	4	5	6	7	8
Press Twice - Range Metres (Supervision time)	30 (15)	40 (15)	50 (15)*	30 (2)	40 (2)	50 (2)		
Press 3 times - Pulse Count	1*	2						
Press 4 times - 'S' Output LUX level	2	5*	10	20	30	40	50	24 hr
Press 5 times - Timer (seconds)	2	5*	10	20	30	40	50	60

\* Default settings

To re-set the default settings remove the batteries, wait 10 seconds, press and hold the program button then re-fit the batteries, the LED will flash rapidly then release the program button.

2. When the 'Program Button' has been pressed the required number of times, wait 4 seconds until the red LED indicator goes off.
3. After a short delay, the LED will then flash a number of times to indicate the existing setting (eg in detector range mode, 3 flashes will show that the existing range has been programmed to 50 metres with a 15 minute supervision timer)
4. To change the setting for that option – wait until the LED stops flashing then press the 'Program Button' the number of times needed to program in the new setting (eg pressing the button twice in range mode will change the setting to 40 metres with a 15 minute supervision timer). The LED will blink twice to indicate that the new setting has been saved.

## Functions

Range settings are self explanatory but for reference, other settings/modes are defined below:

**Pulse Count (1, 2)** – this is the number of times the unit has to detect an intruder on both of its sensors before signalling an activation. The range of the detector will decrease if there is little difference in temperature between the moving object and the background.

- 1 – will give a fast response**
- 2 – gives better immunity with good response**

**LUX 'S' Output only** – 7 settings from 2 to 50 lux – the 8th setting is the 24 hour mode.

a) **LUX** – is a measurement of ambient light levels that must be reached before the 'S' output will become active when there is an activation of the detector (2 is night and 50 is lighter).

b) **24 HOUR** – the detector will operate the 'S' output day and night, irrespective of light levels. All other outputs operate day and night irrespective of the 'S' output setting.

### TIME 'ALARM' OUTPUT TIMER

This is the active time in seconds that the 'alarm' volt free output will activate for after an activation of the detector.

### RF Continuity Test

It is always advisable to test the RF signal at the detector location prior to installation.

To enter the RF continuity test mode – press the 'Program Button' on the D-Tect X MKIII 8 times.

On the 8th press – 'hold' down the 'Program Button' for 5 seconds until the LED goes off – the LED indicator will then flash and transmit one signal per second to the receiver.

The corresponding Channel Indicator on the receiver module will also flash once per second if a strong enough RF link has been established.

This test mode will automatically cancel after five minutes. Alternatively, to cancel the RF continuity test immediately – press and hold the 'Program Button' until the LED illuminates then release the button.

Register one detector as described in 'Code Learning', then conduct an RF continuity test as detailed above. As the signals to the receiver are sent once per second, the optimum position of both the D-Tect X MKIII detector and the receiver box can easily and quickly be established.

### Changing The Random Code

In the unlikely event of another radio signal interfering with and affecting the correct operation of a single RF channel, the D-TectX30 MKIII is able to generate an alternative random code.

To do this, press the **Program Button** on the D-Tect X MKIII nine times. On the ninth press, 'hold' down the button for 5 seconds until the LED goes out, then release the button.

Erase the existing code from the receiver by holding down the **Channel Button** until the alarm LED flashes, then repeat steps 3 to 6 of the **CODE LEARNING** procedure to program in the new code.

## Code Learning

Before the detector is mounted in its desired position, the detector and receiver must be able to communicate with each other, therefore the detector's identification and communication codes must be transferred to the relevant channel in the receiver unit in the following way:

1. Connect a 12-24 volt power source to the receiver and insert the 2 x CR123 lithium batteries into the detector. Always check that the batteries have been inserted correctly. When powered up the detector takes approximately 2-3 minutes to stabilise and the red LED in the detector will flash 3 times when the power is connected.
2. Plug in the **Program Link Wire** from the detector into the **code transfer socket** in the receiver (see **Figure 7**).
3. Press the **'Program button'** on the detector once (see **Figure 6**) The red LED will light.
4. Immediately press the respective **'Channel button'** on the receiver module once and the LEDs will light up for the selected channel. When the red LED on the detector turns off the code is transferred and the 3 LEDs on this selected channel will flash. The code has now been transferred from the detector to the receiver.
5. Remove the link wire from the receiver module and plug it into the **Tamper PCB Connector** on the top of the detector (see **Figure 8**). Repeat steps 2 to 5 for all the detectors to be on the receiver module. The receiver box is equipped with one 4 way PCB module as standard, but can accept up to 3 additional expander modules in total. As each module can communicate with 4 detectors, each receiver box is able to monitor 16 separate wireless D-Tect X detectors.
6. To verify that a code has been stored for any individual detector, press the appropriate **Channel button** on the receiver module once and 4 LEDs will flash 3 times to indicate a code has been stored.
7. To delete a code from a channel, press and hold the **Channel button**; all 4 LEDs will light. Keep the **Channel button** pressed for approximately 4 seconds until the alarm LED flashes, then release the button. The channel is now blank.

## Walk Test

In walk test mode, the detection LED is set to ON. The detection LED lights each time D-Tect X MKIII Wireless Detector detects your presence.

To enter the walk test mode, press the programming button once. The unit can then be aligned. The detection LED lights on D-Tect X MKIII Wireless Detector every time detection takes place.

The test mode ends automatically five minutes after last detection.

**Note: When you conduct a walk test, make sure that the front cover is in place. Do not conduct walk tests with the cover removed.**

The range of the detector increases without the protective front cover. Therefore the front cover must be fitted to establish the correct beam pattern. Pan and tilt the lens module over the field of view to obtain the correct coverage area.

## Tamper Protection

The D-Tect X MKIII Wireless Detector is fitted with two tamper switches to detect the front cover being removed and removal from the fixing surface. The flying lead on the rear of the D-Tect X MKIII Wireless Detector PCB must be plugged into the top PCB for the tamper switches to operate.

## Detector Features

- There are independent front and rear tamper circuits which are combined to provide a volt-free tamper alarm contact.
- The flexibility of the various outputs and timers allows the D-Tect X MKIII to be used in multiple situations without the need for any further customised equipment – and of course as these are wireless movement detectors the installation work is minimal.
- The integral dual axis tilt sensor allows 180 degrees of pan and 90 degrees of tilt. This increases the speed of the outdoor installation and provides incredible accurate aiming of the detection pattern, particularly important for BS 8418 installations.
- The electronics module is acrylic coated for additional component stability
- The sensors are encased in a vandal-resistant high impact ABS housing with a UV stabilised translucent front cover, ensuring the sensor is impervious to and unaffected by adverse weather conditions.
- The combination of precision electronics, digital white light filter and double shielding eliminates false and nuisance alarms from the sun and the visible light sources.
- When a low battery is detected a signal is sent to the receiver unit which displays a low battery indication and operates the 'LOW BATTERY' contacts for the relevant detector.
- The D-Tect X MKIII design has a neat and aesthetically pleasing appearance with no visible indication of the orientation of the detector head.

Specifications	
Detection Range	Programmable: 30m,40m or 50m
Coverage	50 x 10m lens, 13° detection angle, 50m x 10m coverage max.
Supervision	Selectable 2 or 15 minutes
RF Transmission	868 MHz
Adjustment	180° pan, 90° tilt
Fresnel lens	12 Zones for each Pyro pair
Customized Optics	Double silicon shielded quad element eliminates 50,000 lux of white light
LED	Detector alarm / Programming
Batteries	2 x 3 V CR123
Current	25 µA
Pulse Count	1,2
Control	Digital microprocessor with non-volatile memory
Adjustable Timer Options	2 to 60 Seconds
Adjustable Light Sensing	2 Lux to 24 hr
Walk test	Output test mode with LED indication.
Operating temperature	-20 to +55°C
Housing	High impact ABS plastic with HDPE cover, UV stabilized
Protection rating	IP 65
Dimensions, H x W x D	145 x 120 x 155
Weight	363 g net, 575 g gross excluding transmitter and batteries
Mounting height	Variable - optimum height 3 m for full range

Figure 1

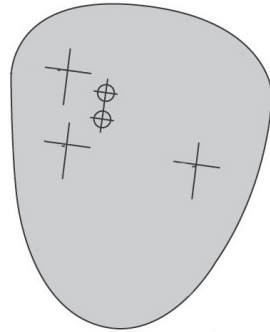

Figure 2

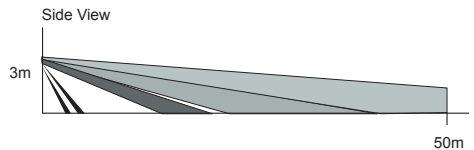

Figure 3

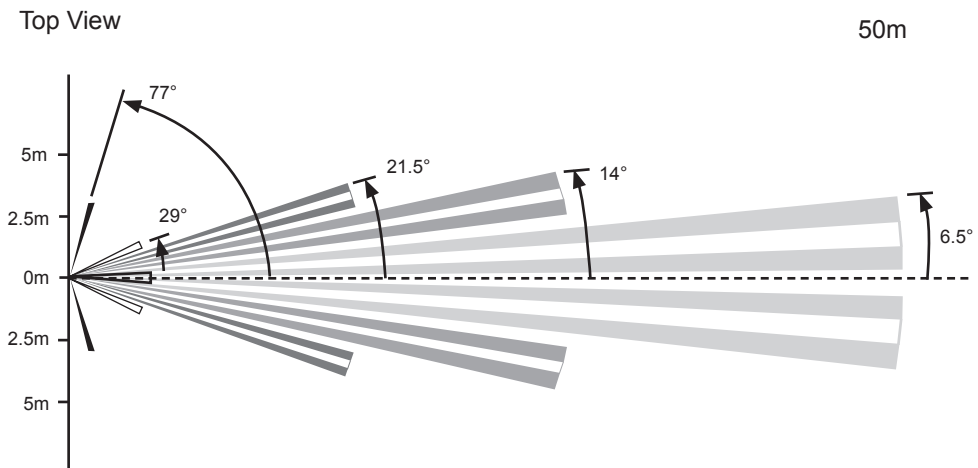

Figure 4

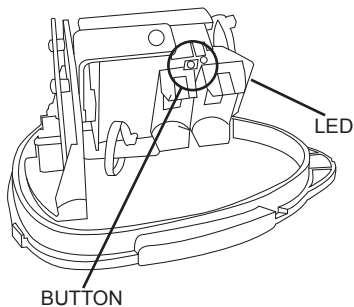

Figure 5

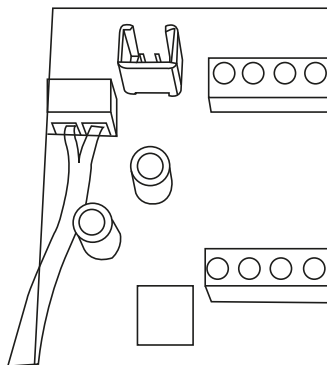
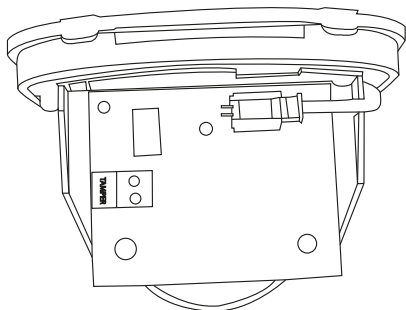

Figure 6



# Engineer Notes

---

Technical: 01706 363990

Sales: 01706 363998

Fax: 01706 363991

Email: [info@gjd.co.uk](mailto:info@gjd.co.uk)

Unit 2, Birch Business Park, Whittle,Lane,Heywood,OL10 2SX