

# EBDDH

Enclosure for duct application smoke detectors



The EBDDH duct adaptor is a passive monitoring system based on the Venturi principle. It provides early warning of smoke by continually sampling air movement within heating and ventilation ducts. One of the main aims of duct-smoke detection is to minimize the propagation of smoke through air vents and therefore reduce the risk of panic, injury and damage to property. INIM offers a full range of products for this type of system. The optimal response of this system is achieved by the continuous sampling of the one-way air flow that passes through the sampling pipes at a velocity of between 0.5 to 20 metres per second. The duct adaptor accepts conventional detectors from the IRIS series as well as analogue detectors from the ENEA series (the detectors and bases must be purchased separately).

Alarm conditions are signalled on the front of the apparatus through the detector signalling LED.

The air-sampling pipe is available in three different lengths: 0.6m, 1.5m, 2.8m. It should be chosen in accordance with the width of the duct concerned. The sampling pipe must traverse at least 90% of the duct. If the duct is wider than 60cm, the sampling pipe must traverse the entire duct.

The adaptor is fitted with a red plastic tongue which indicates the air flow to the detector and thus confirms that air flow from the duct is passing through properly.

## Main features

- Single pipe air-sampling system.
- Test hole on cover.
- Easy installation.
- Air flow indicator.
- Filter to reduce dust and other deposits on the detector.
- Efficient service and easy maintenance.

## Technical specifications

- Dimensions (without pipe): 180x183x235 mm.
- Weight: 700 g.
- Sampling pipe length: 0.6, 1.5, 2.8 m.
- Air velocity: 0.5/20ms.
- Enclosure: ABS.
- IP Rating: IP54.
- Detector compatibility: ED100 and ID100.

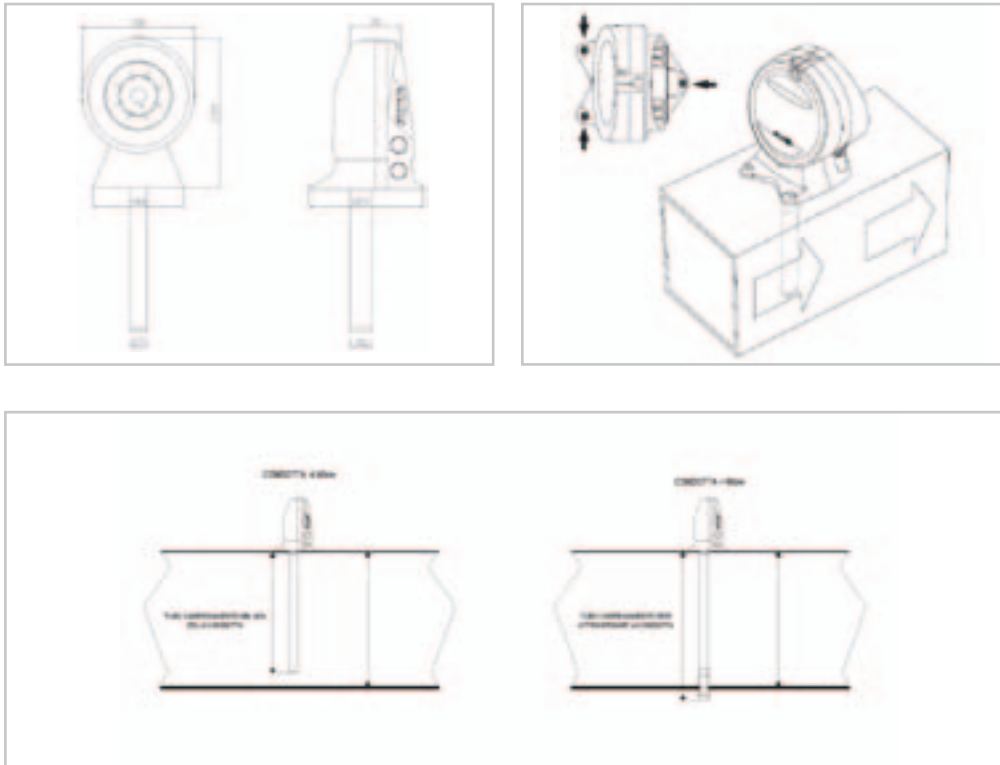

## ORDER CODES

**EBDDH:** Universal pipe adaptor.

**TV-0.6:** 0.6m sampling pipe.

**TV-1.5:** 1.5m sampling pipe.

**TV-2.8:** 2.8m sampling pipe.

**DDH-BRKT:** Mounting bracket for circular ducts.

**DDH-COVER:** Weatherproof cover.

**DDH204:** Set of spare gaskets.

**DDH F1/10:** Dust filter.

## REFER TO

**ITI029:** EBDDH in circular duct.

**ITI030:** EBDDH in rectangular duct.