



EN 54-2
EN 54-4
EN 12094-1



0051-CPD-0224
0051-CPD-0229
0051-CPD-0230



SmartLine
Conventional fire detection control panel
Extinguishant system control panel
Installation and programming manual



GameOver



Copyright

The information contained in this document is the sole property of INIM Electronics s.r.l.. No part may be copied without written authorization from IINIM Electronics s.r.l..

All rights reserved.

European directive compliance

This Control panel has been designed and developed to the highest standards of quality and performance implemented by INIM Electronics s.r.l..

This control panel must be installed in accordance with the instructions described in this manual and in compliance with the laws in force.

All control panels from the **SmartLine** series are **EN54-2**, **EN54-4** and **EN12094-1** compliant.

All control panels from the **SmartLine** series, and all accessory items and special functions have IMQ Security systems certification, unless otherwise stated.

Table of contents

	European directive compliance	2
	Table of contents.....	3
Chapter 1	Overview.....	5
1.1	Application and use	5
1.2	Other parts of the system	7
1.3	The SmartLine fire alarm panel models	7
Chapter 2	General information	8
2.1	In-box documentation	8
2.2	Manual details	8
2.3	Firmware information	8
2.4	Operator qualifications - access levels	8
2.5	Intellectual property rights	8
2.6	Disclaimer	9
2.7	Recommendations	9
2.8	Testing the system	9
2.9	Note to the installer	9
2.10	Technical support	9
2.11	Conventions	9
2.12	Menu paths	10
2.13	Device identifier	11
2.14	Warranty	11
2.15	Safety laws	12
Chapter 3	Device management	13
3.1	Product handling and storage	13
3.2	Environmental conditions	13
3.3	Unpacking the device	13
Chapter 4	Technical description.....	15
4.1	Internal devices	15
4.2	Technical specifications	16
4.3	PCB current draw	16
Chapter 5	User interface	17
5.1	SmartLine panel frontplate	17
5.2	Repeater (optional system enhancement panel)	21
Chapter 6	Installation instructions	24
6.1	Mounting the SmartLine/8Z expansion board (accessory item)	24
6.2	Mounting the SmartLAN/485 ethernet board (accessory item)	25
6.3	Mounting the SmartLetLoose/ONE extinguishant board (accessory item)	26
6.4	Wall mounting	26
6.5	Connecting the lines	27
6.6	Connecting the Dialer	31
6.7	Connecting the RS485 BUS	32
6.8	Connecting the fault signaling outputs	33
6.9	Connecting the Alarm signaling output	33
6.10	Connecting NAC outputs to the Smart/8Z expansion board	34
6.11	Connecting AUX and AUX-R outputs	34
6.12	Connecting RELAY output	35
6.13	Connecting the Extinguishant module (optional system enhancement tool)	35
6.14	Connecting the Mains	37
6.15	Connecting the batteries	38
6.16	Thermal Probe	38

Chapter 7	Powering up and configuring the system.....	40
7.1	Testing wiring integrity	40
7.2	Connecting the RS232 PC serial link	40
7.3	Powering up the system	41
Chapter 8	Introduction to Programming form the panel	43
Chapter 9	Programming from panel	44
9.1	Configuring the control panel	44
9.2	Programming the zones	44
9.3	Setting the Timers	50
9.4	Setting holidays	51
9.5	Setting the control panel options	51
9.6	Setting up equations	52
Chapter 10	Detection line threshold-adjustment.....	53
Chapter 11	Programming the extinguishant module.....	54
11.1	Configuring the extinguishant module	55
11.2	Programming the module	55
11.3	Programming extinguish inputs/outputs	56
Chapter 12	Configuring the devices connected to the RS485 BUS	57
Chapter 13	Closing the programming session	58
13.1	Restoring factory settings	58
Chapter 14	SmartLeague software	59
14.1	Overview	59
14.2	The Solutions	59
14.3	Enable programming via PC	59
Chapter 15	Maintenance	60
15.1	Set Time and date	60
15.2	Viewing events	60
15.3	Day/Night Mode	60
15.4	Bypassing a zone	61
15.5	Bypass the DIALER or ALARM NAC output	61
15.6	Testing the zones	61
15.7	Force the status of I/O lines configured as outputs	61
15.8	Set the date for the next maintenance session	62
15.9	Reading the power supply tension	62
Chapter 16	Diagnostics and fault solutions	63
16.1	Fault "Open"	63
16.2	Fault "Shorted"	63
16.3	Repeater faults	63
16.4	Battery Fault	63
16.5	Other faults	64
Appendix A	Iris devices.....	65
Appendix B	Order Codes	67

Overview

Note: *The control panels described in this manual have been designed and developed to the highest standards of quality, reliability and performance. All product components are capable to application requirements and able to operate in compliance with the related technical specifications when the temperature external to their casing complies with Category 3k5 of EN60721-3-3:1995.*

Danger: **The GAS control function is not provided for in the aforesaid standard and therefore cannot be considered EN54-2 compliant.**

Danger: **In order to validate the IMQ-SECURITY SYSTEMS certification, and in compliance with EN54-2, all the manual alarm buttons and fire detectors employed in the system must be associated with fire detection and alarm functions.**

1.1 Application and use

The SmartLine conventional fire control panel manages up to 20 conventional detector lines (zones) for SmartLine020 models or up to 36 lines for SmartLine036 model. Each line (zone) accepts up to 30 devices and is provided with an additional I/O line that can be configured as an open-collector output (the activation principles can be defined during the configuration phase) or as an independent input line (separate from the zone) for fire detection, gas detection line, etc. The basic model has 4 on-board zones (2 for the SmartLine020-2 model) expandable to 20 (or 36 for the SmartLine036) by means of 2 SmartLine/8Z optional attachment boards (8 lines per board).

The control panel also provides a series of outputs for the activation of signaling or remote transmission devices. The graphic display and LEDs provide visual indication of the system status and real-time signaling of fault conditions. The control panel supports up to 4 repeater panels (SmartLetUSee/LCD-Lite); these remote consoles replicate all the information provided by the control panel and allow access to level 1 and 2 functions. The control panel can also house and manage the SmartletLoose/ONE gas extinguishant module (optional attachment board).

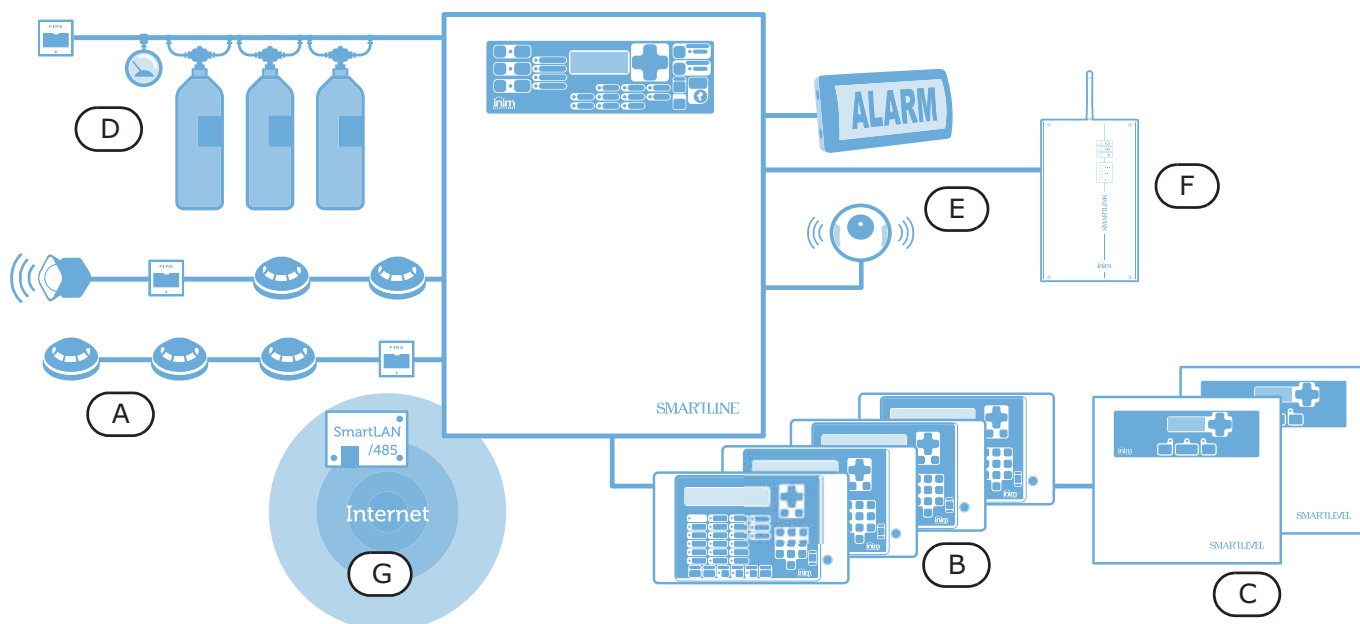

Figure 1 - Example of a typical SmartLine installation

[A] The zones

Each zone is provided with a pair of terminals (lines) for the connection of the fire-detection devices deployed in the protected area. Each line (zone) accepts up to 30 devices (conventional detectors or callpoints). The control panel can be configured to discriminate between detector and callpoint triggered alarms. Each line can be configured to activate various signals (fire alarm, gas alarm, etc.).

The lines accommodate:

1. **Detectors:** A detector is an active fire protection device that detects smoke or flames and issues an alarm thereby alerting building occupants to the danger of fire. They can be:
 - Optical smoke detectors which look for the presence of visible by-products of combustion in the detection chamber (Tyndall effect).
 - Optical/Heat detectors which operate as per optical smoke detectors but also sense for increase in the environment temperature. The combination of both sensing methods (smoke and heat) provides faster detection and reduces the false alarm rate.
 - Heat detectors which sense for an increase in the temperature in the protected environment. There are two types of heat detector: Fixed temperature — that signal alarm when the temperature exceeds the predefined threshold; and Rate-of-rise — that as well as monitoring the predefined fixed temperature also respond to rapid increase in temperature.
 - Ionization smoke detectors: feature a harmless radioactive source within a dual detection chamber. They operate by sensing for a change in electrical conductivity across the detection chamber.
 - CO detectors: sense the levels of carbon monoxide given off by all carbon-based materials in the smouldering stages of a fire (often combined with heat detection sensor).
2. **Callpoint:** a clearly indicated fire button with instructions for use in the event of fire. Usually located near the entrance/exit of the protected building. These push-button alarm-trigger devices allow building occupants to activate system alarms.

For further information regarding the list of the detectors the lines accommodate, and for details regarding their operating principles, refer to Chapter 10 - *Detection line threshold-adjustment*.

Danger: In order to comply with EN54-2 requirements, no more than 30 detectors/devices should be connected to each line.

Each detection line must be terminated with a 3900 ohm resistor (included), in such way as to allow the control panel to monitor the integrity of the wiring.

[B] SmartLetUSee/LCD-Lite repeater (accessory item)

This optional system enhancement tool (equipped with keypad, LEDs, fast buttons and display) replicates all the system data. The panel supports 4 repeaters which can be connected to RS485 BUS (maximum cable length 1000m from panel). Repeaters are usually located near the entrance/exit of the protected building, in order to allow users to view the system status without going too far inside the building.

[C] SmartLevel power-supply stations (accessory items)

The SmartLevel is the ideal power source for all devices located in the area protected by the detection system. Its internal board satisfies all EN54 requirements and provides complete supervision of the power station. The device can be connected to the control panel by means of the RS485 BUS, thus allowing the complete supervision of the power station and control of the 3 outputs.

[D] Gas extinguishant system (optional system enhancement feature)

The panel can house and manage a gas extinguishant module (SmartLetLooseONE, optional). The Gas extinguishant module is compliant with *EN 12094-1*.

[E] Sounderflashers

These audible/visual signaling devices connect to the control panel outputs and activate when specific conditions occurs. The cause of activation (alarm, pre-alarm, early warning, etc.) can be defined during the system configuration phase.

[F] SmartLink telephone dialer

INIM's SmartLink/G and SmartLink/GP telephone dialers monitor the analogue landline and, in the event of landline problems (line cutting, etc.) divert incoming and outgoing calls to the GSM network. The Smartlink/P model operates solely over the PSTN line (landline).

[G] SmartLAN/485 Ethernet connection board (accessory item)

Allows the control panel to connect to an Ethernet network for remote connection. So it is possible to modify the configuration parameters (up-download programming data) and/or manage the system using the SmartLook supervision software based on graphical maps.

1.2 Other parts of the system

Zone: a group of points (detectors, etc.) connected to a detection line. The control panel provides an extra terminal (I/O) for each zone. If the terminal (I/O) is configured as an input, the control panel will be able to split the detection line of each zone. This feature can be used when zones require a detector line that is separate from the callpoint line in order to ensure proper operation of one line in the event of fault on the other.

Power Supply (Figure 30 - *Connecting the Mains*): a module, connected to the mains 230 Vac, that provides a stabilized voltage @ 24 V (27.6 V) to the system and the charge source to the batteries. The EN54-4 compliant power-supply module is housed below the motherboard. The mains voltage (230 Vac) is the primary power source of the system. Refer also to paragraph 6.14 - *Connecting the Mains*.

Batteries: the secondary power source of the system. The panel houses two lead batteries @ 12V 7Ah (connected in series). The system monitors the battery status (efficiency and charge). In the event of inefficient or low battery conditions, the system will signal battery fault. If primary (230 Vac) power failure occurs, the batteries will take over, however, they will shutdown automatically if the blackout persists. The automatic battery shutdown feature prevents irreparable damage to the batteries. Refer also to paragraph 6.15.

Thermal probe: an accessory tool, to be connected to the panel and attached to the battery pack. This device monitors the temperature of the external battery pack and regulates the battery charge accordingly. Refer also to paragraph 6.16.

RS485 BUS: 4 wire BUS for the repeater connections. Four pole twisted-shielded cable must be used for all connections. Refer also to paragraph 6.7 - *Connecting the RS485 BUS*.

Timer: a logical entity (the panel provides 8 timers) for automatic time-management of preset intervals (2 intervals per day) on preset days of the week and specific dates. The timers can be used in equations to manage predefined operations or activate outputs.

Equation: a group of logical conditions defined by the installer. An equation comprises a series of operators (AND, OR, +, etc.) and a series of operands (Points, Zones, Timers, etc.). An equation can be associated with an output that will activate when the equation is satisfied.

Holidays: a list of days defined during the system configuration phase that can be associated with a timer.

1.3 The SmartLine fire alarm panel models

The available models are:

- SmartLine020-2 - Conventional fire alarm control panel with 2 zones non expandable
- SmartLine020-4 - Conventional fire alarm control panel with 4 zones expandable to 20
- SmartLine036-4 - Conventional fire alarm control panel with 4 zones expandable to 36

General information

2.1 In-box documentation

- Installation and programming manual (this manual)
- User's manual

The Installation manual is inside the device package. For further copies of the installation manual, please contact INIM Electronics s.r.l. offices quoting the order number shown in Appendix B - *Order Codes*.

2.2 Manual details

- Title: SmartLine installation and programming manual
- Version: 3.00
- Month and year: May 2011
- Manual code: DCMIINE0SLINE
- Addressees: installers, technical assistance

2.3 Firmware information

- SmartLine firmware version: 2.x.x
- Extinguishant module firmware version: 1.0.x

2.4 Operator qualifications - access levels

The SmartLine is EN-54 compliant. There are four access levels:

Level 1: The public

All building occupants can view the system status (active events) and events log; silence the panel beeper and, under pre-alarm conditions, override pre-alarm status and activate an instant alarm.

Level 2: Authorized operators — person/s responsible for the safety of the building and its occupants.

Authorized operators (keyswitch and PIN users) can silence the outputs, reset the panel, activate the 'Investigation' delay, disable zones, points and outputs, change the operating mode (Day/Night) and activate the 'Evacuation' alarm.

Level 3: Authorized technicians appointed by the Installer company.

Such technicians possess the tools required for the removal of the control panel frontplate. And, are allowed to insert the jumper which enables the control panel programming phase (via control panel or PC), in order to access the programming and maintenance functions. The control panel is unable to process data or generate fault or alarm signals of any kind during the programming phase.

Level 4: Authorized technicians, appointed by the Manufacturer (INIM Electronics s.r.l.).

The manufacturer company technicians can, by means of special tools, repair or replace the control panel components.

Note: *This manual is for Authorized installer company technicians (Level 3). However, it also provides some installation information related to level 1 and level 2.*

2.5 Intellectual property rights

The information contained in this document is private property. All rights reserved.

No part of this document may be copied or reproduced unless expressly authorized in writing by INIM Electronics, in particular the parts regarding the device specified in paragraph 2.13.

2.6 Disclaimer

INIM Electronics s.r.l. shall not be responsible for damage arising from improper application or use.

This control panel should be handled by qualified personnel only. Installation must be carried out strictly in accordance with the instructions described in this manual, and in compliance with the local fire code in force.

2.7 Recommendations

INIM Electronics recommends that the entire system be tested on a regular basis (refer to paragraph 2.8 - *Testing the system*).

2.8 Testing the system

This system has been designed to the highest standards of quality and performance. The system may fail to function as intended due to the failure of a component. Most problems that prevent a fire control system from operating as intended can be found by regular testing and maintenance (refer to Chapter 15 - *Maintenance*).

Testing should include all detectors, signaling devices and any other operational devices that are part of the system.

2.9 Note to the installer

In order to provide adequate protection and instructions for proper use, you (the installer) must be familiar with the operating procedure of this device. As the only individual in contact with system users, it is your responsibility to instruct them on how to use this system properly and to bring to their attention that every fire is different in the amount of smoke and rate of burning. Therefore, smoke and heat detectors may not provide timely warning of fires caused by violent explosions, escaping gas or improper storage of inflammable materials.

Regardless of its capabilities, a fire alarm system is not a substitute for the necessary precautions building occupants must take to prevent or minimize the harmful effects of fire.

2.10 Technical support

Our professional engineers are readily available to assist you. Call our phone number and you will be connected right away to a person who will answer all your questions and provide you with full technical support.

2.11 Conventions

2.11.1 Glossary and terminology

Panel; device; system: refer to the devices defined in paragraph 2.13.

Left, right, behind, above, below: refer to the directions as seen by the operator in front of the mounted device.

Communicator (telephone, SMS, digital): synonym of dialer.

STP: Shielded twisted pair cable.

Qualified personnel: those persons whose training, expertise and knowledge of the laws and bylaws regarding service conditions and the prevention of accidents, are able to identify and avoid all possible situations of danger.

Select: click on and select a specific item (from drop-down menu, options box, graphic object, etc.).

Press: click on a video button, or press a key on the panel keypad.

2.11.2 Graphic conventions

Following are the graphic conventions used in the text. For a description of the graphic conventions relating to the interface, refer to paragraph 5.1 - *SmartLine panel frontplate*.

Conventions	Example	Description
<i>Text in Italics</i>	Refer to paragraph 4.1 - <i>Internal devices</i>	Text in italics: indicates the title of a chapter, section, paragraph, table or figure in this manual or other published reference.
<text>	#<CustomerCode>	Variable data.
[lowercase letter] or [number]	[A] or [1]	Representation of a part of the system or video object.
BUTTON	Esc, RESET	Computer or control panel keys.

Note: *The detached notes contain important information about the text.*

Attention: **The attention prompts indicate that total or partial disregard of the procedure could damage the connected devices.**

Danger: **The danger warnings indicate that total or partial disregard of the procedure could injure the operator or persons in the vicinity.**

2.12 Menu paths

Example

From panel: <key>, **Programming, Progr. zone**, select a zone, **Ok**

Via software application: **Control panel, Zones**

Access to specific functions can be achieved by using the panel keys or PC video objects and the respective path.

Note: *This manual describes the recommended programming flow.*

Attention: **For most part this manual describes programming from the control panel.**

2.13 Device identifier



Figure 2 - Overview

<div style="text-align: center;"> <p>0051</p> <hr/> <p style="text-align: center;">09 0051 - CPD - 0230</p> <p style="text-align: center;">Control and signaling panel with integrated power-source devices. SmartLine020-2</p> <hr/> <p>EN54-4: 1997/ A2: 2006 EN54-4: 1997/ A1: 2006 Isolation: Class I Available options: - 7.8 Sounder circuits output - 7.11 Delayed outputs - 7.12 Alarm on two points activation - 8.3 Fault from points signal - 8.9 Monitored output for remote signalling - 9.5 Points isolation - 10.0 Test condition</p> <hr/> <p>Manufacturer: INIM Electronics s.r.l. Address: via Fosso Antico, Centobuchi 63076, Montepandone (AP), Italy</p> </div>	<div style="text-align: center;"> <p>0051</p> <hr/> <p style="text-align: center;">09 0051 - CPD - 0229</p> <p style="text-align: center;">Control and signaling panel with integrated power-source devices. SmartLine020-4</p> <hr/> <p>EN54-4: 1997/ A2: 2006 EN54-4: 1997/ A1: 2006 Isolation: Class I Available options: - 7.8 Sounder circuits output - 7.11 Delayed outputs - 7.12 Alarm on two points activation - 8.3 Fault from points signal - 8.9 Monitored output for remote signalling - 9.5 Points isolation - 10.0 Test condition</p> <hr/> <p>Manufacturer: INIM Electronics s.r.l. Address: via Fosso Antico, Centobuchi 63076, Montepandone (AP), Italy</p> </div>	<div style="text-align: center;"> <p>0051</p> <hr/> <p style="text-align: center;">09 0051 - CPD - 0224</p> <p style="text-align: center;">Control and signaling panel with integrated power-source devices. SmartLine036-4</p> <hr/> <p>EN54-4: 1997/ A2: 2006 EN54-4: 1997/ A1: 2006 Isolation: Class I Available options: - 7.8 Sounder circuits output - 7.11 Delayed outputs - 7.12 Alarm on two points activation - 8.3 Fault from points signal - 8.9 Monitored output for remote signalling - 9.5 Points isolation - 10.0 Test condition</p> <hr/> <p>Manufacturer: INIM Electronics s.r.l. Address: via Fosso Antico, Centobuchi 63076, Montepandone (AP), Italy</p> </div>
--	--	--

Figure 3 - CE Approval

2.14 Warranty

INIM Electronics s.r.l. warrants the original purchaser that for a period of 24 months from the date of final acceptance, the product shall be free of defects in materials and workmanship. The warranty applies only to defects in parts and workmanship relating to normal use. It does not cover:

- Improper use or negligence
- Damage caused by fire, flood, wind or lightning
- Vandalism
- Fair wear and tear

INIM Electronics s.r.l. shall, at its option, repair or replace any defective products. Improper use, that is, use for purposes other than those mentioned in this manual which is the cause of fault or damage to the system, will void the warranty. For the full details and conditions regarding the warranty, refer to the purchase order.

2.15 Safety laws

The aim of the instructions in this section is to ensure that the device is installed and handled properly. This chapter contains vital information. The installer should be familiar with this section and bring each item to the attention of the system users.

2.15.1 Compliancy

The design and manufacture of the SmartLine panel conform with EN 54-2 *Fire detection and signaling systems - Control and signaling panels*.

The design and manufacture of the power supply comply with EN 54-2 *Fire detection and signaling systems - Power supply devices*.

The SmartLetLoose/ONE extinguishant board enhanced SmartLine control panel has been developed and designed in compliance with EN 12094-01 *Fire-fighting Systems - Components of fire-extinguishant systems - Part 1: Requirements and testing methods for automatic electrical command and fire-extinguish or delay management devices*.

2.15.2 Managing electronic devices

The normal motions of any person may generate electrostatic potential of thousands of volts. Discharge of this current through semiconductor devices during handling may cause serious damage which although may not be immediately evident may reduce the reliability of the circuits.

If located in their housings, the electronic circuits of INIM Electronics products are highly immune to electrostatic discharge.

Do not expose the circuits to damage by removing the modules unnecessarily from their housings.

- When removing or handling the boards, hold the board edges only.
- Do not touch the electronic components, the printed circuits or the metal parts of the connectors.
- Do not hand the module to another person without first ensuring that you both have the same electrostatic potential. This can be achieved by simply shaking hands.
- Place the board on an anti-static surface or a conductor surface with the same potential.

Further information regarding procedures relating to safety when working with electronic devices can be found in Directive *IEC 60147-0F*.

2.15.3 Setting up the system

In order to provide adequate protection and instructions for proper use, security professionals (Installers and maintenance technicians) must be familiar with the operating procedure of this device.

Please read the instructions carefully before installing and/or servicing the system.

Before first power-up, be sure that the earth connection has been completed properly on the respective terminal.

The recommended minimum wire cross section for the earth connection is 2.5 mm², that is, unless otherwise stated in accessory documentation.

2.15.4 Replacement and disposal of used devices

Replacement

When replacing used devices, disconnect the devices concerned then complete the connections of the new devices in compliance with the instructions printed on the respective leaflets.

In order to avoid short-circuits, take all the necessary precautions when removing used batteries.

Disposal

Do not burn used electronic devices, or allow them to pollute the environment (countryside, rivers, etc.). Electronic devices must be disposed of in a safe environment-friendly way.

Contact your local municipal offices for information regarding the disposal of electronic devices and/or batteries.

Device management

3.1 Product handling and storage

This device is safely packed inside a cardboard box, however, care must be taken to avoid accidental damage during handling. Cartons/boxes should be placed in such a way as to avoid knocks and falls, and special care must be taken to protect the devices from extreme heat and/or cold.

3.2 Environmental conditions

Temperature limits:

-10° / +55°C for transport and storage

-5° / +40°C operating temperature

3.3 Unpacking the device

Take due care when unpacking the product, and dispose of all waste packaging in accordance with the local method of disposal.

The cardboard box contains the SmartLoop control panel (cabinet in metal).

Note:

The two lead batteries are not included. Be sure you have the batteries on hand before starting.

When you remove the four screws and metal-frontplate, you will find:

- The SmartLine motherboard mounted on a plastic support that bridges the two sides of the metal box.
- Power supply module located under the plastic support. The power supply module is connected to the SmartLine motherboard.
- A plastic bag containing:
 - Battery connection wires
 - Key for access level 2
 - Resistors and EOL diodes for supervised circuits
 - Expansion board connection cable (SmartLine036 only)

The following accessory items must be ordered separately (see Appendix B - *Order Codes*):

- [A] SmartLetLoose/ONE - extinguishant board
- [B] SmartLetUSee/LCD-Lite - repeater panel
- [C] ProbeTH - thermal probe battery-charge optimizer
- [D] SmartLevel - power-supply station
- [E] SmartLine/8Z - 8 zones expansion board
- [F] SmartLAN/485 - ethernet interface board



Figure 4 - Accessory devices

Technical description

4.1 Internal devices

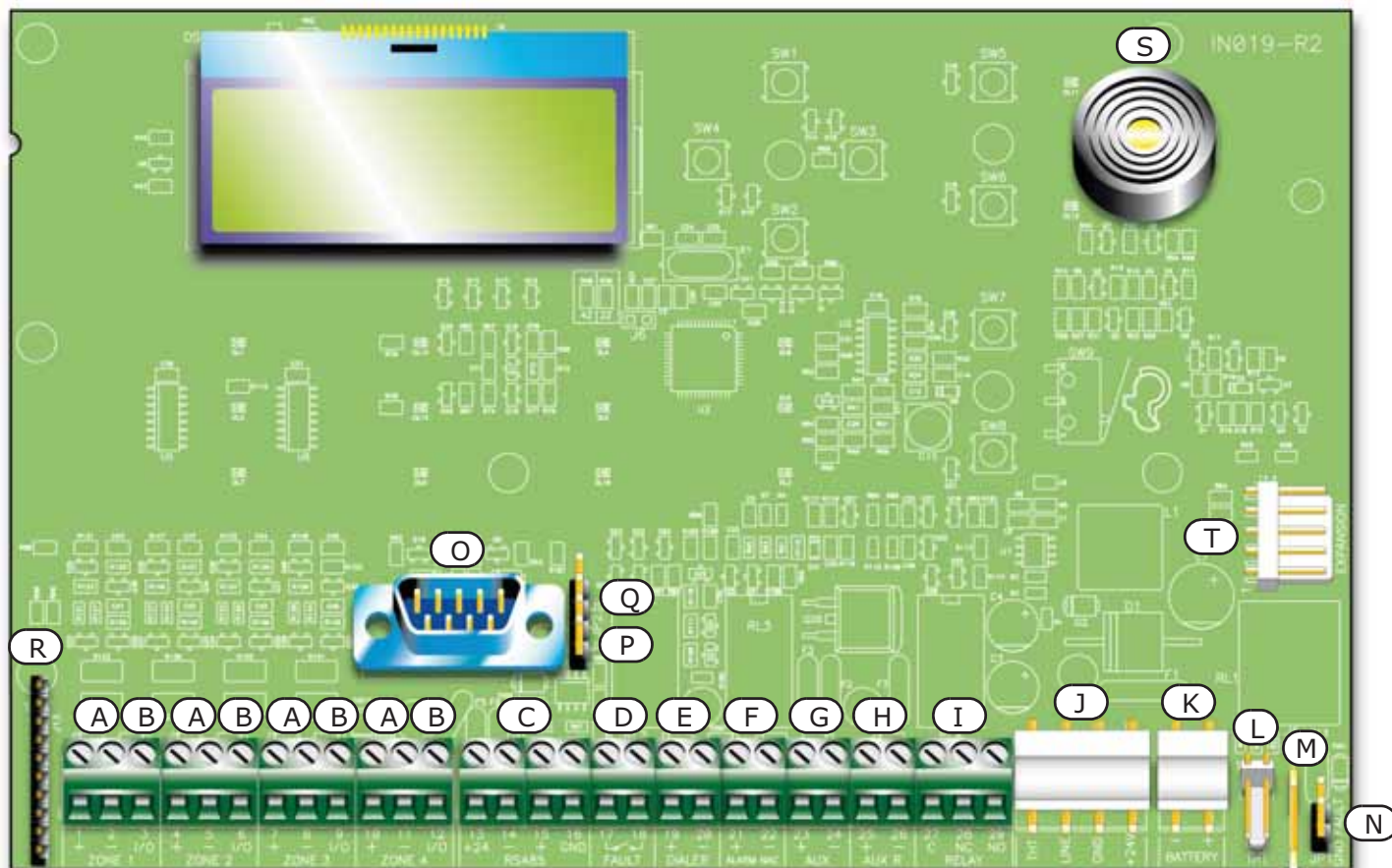

Figure 5 - SmartLine motherboard

Main components:

[A]	ZONE +/-	Zone detection-line terminals
[B]	ZONE I/O	Zone I/O terminals
[C]	RS485	RS485 BUS terminals for repeater and poer station connections, max. 0.9 A
[D]	FAULT	Fault output, dry contact
[E]	DIALER	Output terminal for dialer connection, supervised
[F]	ALARM NAC	Supervised alarm output
[G]	AUX	24 V 0.8 A output for external loads
[H]	AUX R	24 V 0.8 A output for external loads - off during reset
[I]	RELAY	Programmable dry contact (Alarm at default)
[J]		Power-supply module connector
[K]		Battery connector
[L]		Thermal probe connector for batteries
[M]		Connector for the earth wire of the power supply module
[N]		Earth-fault-bypass jumper - if this jumper is removed faults will be bypassed
[O]		RS232 serial port for PC connection

[P]	Jumper for programming from panel (keypad and LCD) J8
[Q]	Jumper for programming from PC J9
[R]	Extinguishant module connector
[S]	Buzzer
[T]	Connector for expansion board

Note: *INIM s.r.l. reserves the right to change, replace, in part or entirely, the components not strictly relating to the user and therefore, which do not involve the installation process described in Chapter 6 - Installation instructions.*

4.2 Technical specifications

Specification	SmartLine020	SmartLine036
AC power	230 Vac (-15% + 10%) 50/60 Hz	
Maximum current draw 230V	0.5 A	0.9 A
DC current	1.4 A	4 A
Nominal output voltage	27.6 V	
Maximum current for external loads, boards and optional devices	0.9 A	2.8 A
Maximum current draw on terminal + AUX	0.8 A	
Maximum current draw on terminal + AUX-R	0.8 A	
Current ripple on AUX and AUX-R outputs	1% MAX	
Maximum battery-charge current	400 mA	1 A
Battery specifications	2 x 12 V/7 Ah YUASA NP-12 FR or similar with case flame class UL94-V2 or higher	2 x 12 V/17 Ah YUASA NP-12 FR or similar with case flame class UL94-V2 or higher
Maximum battery internal resistance ($R_{i \max}$)	32 Ohm	
Output current	19V - 27.6V	
Fuse (F2) - switching power supply	F 6.3 A 250V	
Fuse (F1) - switching power supply (not resettable)	T 3.15 A 250V	
Maximum output current ripple	1%	
Operating temperature	-5°C to 40°C	
Dimensions	325 x 325 x 80 mm	497 x 380 x 87 mm
Weight	2.8 Kg	6 Kg

4.3 PCB current draw

Module	Standby current draw	Maximum current draw
SmartLine motherboard	90 mA	90 mA
SmartLAN/485 board	50 mA	50 mA
SmartLine/8Z board	50 mA	50 mA
SmartLetLoose/ONE board	10 mA	70 mA
SmartLetUSee/LCD-Lite repeater	40 mA	80 mA

User interface

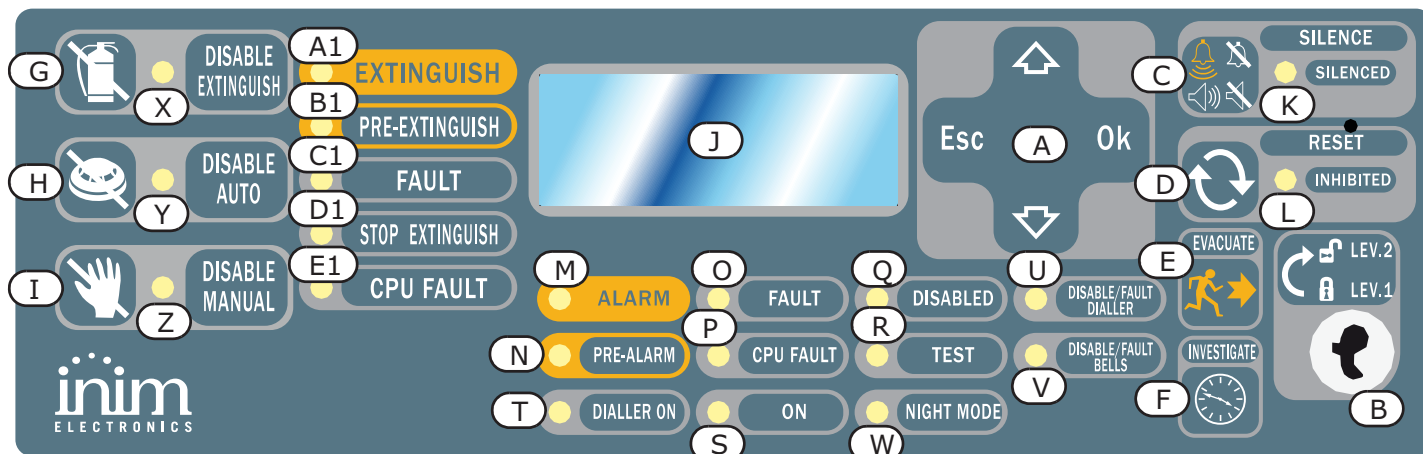

Figure 6 - Frontplate

5.1 SmartLine panel frontplate

5.1.1 Commands

Command	Access level 1	Access level 2	Note
[A] Navigation keys			To be used to navigate through the menus on the display. The effect these keys have during programming depends on the specific field. See Chapter 8 - <i>Introduction to Programming form the panel.</i>
[B] Keyhole for the access level 2 key	Key not inserted or inserted in vertical position	Key inserted in horizontal position	When the key is removed or placed in the vertical position and no key is pressed, the control panel will hold access level 2 status for 20 seconds.
[C] SILENCE	Push this button to silence (turn off) the panel beeper.	Silences (turns off) active outputs with the silenceable attribute. The silenceable outputs will hold silenced status until a new event occurs that releases the outputs automatically. The SILENCE button operates as a toggle switch, therefore, silenced outputs can be unsilenced by pushing the button again.	If the system is operating in Night mode, SILENCE status will be held for the preset SILENCE time only. This is a safety precaution designed to protect building occupants and persons in charge of night-security who, after silencing the system, may be overcome by smoke or fumes during fire investigation and unable to restart the alarm signaling devices manually.
[D] RESET		Push this button to clear any active events, delete the memory and restore standby conditions.	Any alarm/fault conditions which persist after RESET operations will generate new alarm/fault signals.

Command	Access level 1	Access level 2	Note
[E] EVACUATE	If this button is pressed during active pre-alarm conditions, the system will override the programmed pre-alarm time and generate an instant alarm (i.e. activate all evacuation-warning devices).	If this button is pressed when pre-alarm conditions are not active, the system will generate a panel alarm.	
[F] INVESTIGATE		If this button is pressed during active pre-alarm conditions, the system will add the preset investigation time to the running pre-alarm time (this operation can be done once only).	The extended alarm delay will allow authorized building occupants and/or security staff to check and verify the fire hazard.

Extinguishant module (accessory item) commands

[G] DISABLE EXTINGUISH		If this button is pressed once, the system will disable Extinguish commands. If this button is pressed again, the system will re-enable Extinguish commands.	This button can be used during testing and maintenance of the fire extinguishant devices.
[H] DISABLE AUTO		If you push this button once, the system will disable automatic extinguish commands generated by the Extinguishant module. If you push this button again, the system will re-enable automatic extinguish commands generated by the Extinguishant module.	
[I] DISABLE MANUAL		If you push this button once, the system will disable manual extinguish commands. If you push this button again, the system will re-enable manual extinguish commands. Refer also to paragraph 6.14 - <i>Connecting the Mains</i> .	

5.1.2 Signalling

LED	On solid:	Blinking:	Note
[J] Display			See Chapter 8 - <i>Introduction to Programming form the panel</i> .
[K] SILENCED (yellow)	Indicates that the system has been silenced.		
[L] RESET INHIBITED (yellow)	In the event of pre-alarm/ alarm, indicates that reset commands are not allowed. Reset will be allowed when all outputs have been silenced and this LED goes off.		This feature ensures that persons responsible for the safety of the building and its occupants do not reset the system without first silencing the outputs, and evaluating the alarm. The silence operation will stop the signaling devices and restore quiet thus allowing the operator to consider the best way to proceed. The operator will then be able to reset the system and restore standby status.

	LED	On solid:	Blinking:	Note
[M]	ALARM (red)	Signals an alarm condition, that is, activation of a zone point (detector, callpoint, etc.) that is programmed with the alarm attribute.		Examples: a smoke detector has sensed a quantity of smoke that exceeds its alarm threshold; a heat detector has sensed rise in temperature that exceeds its alarm threshold; a callpoint has been activated, etc. Authorized persons only (level 2) can clear these conditions (which may occur after an early warning, pre-alarm, etc.) by means of silence/reset operations. Signaling will continue even after the cause of the alarm has ceased.
[N]	PRE-ALARM (red)	Signals a pre-alarm condition, that is, activation of a zone point (detector, callpoint, etc.) that is programmed with a pre-alarm time.		Examples: a smoke detector has sensed a quantity of smoke that exceeds its alarm threshold; a heat detector has sensed rise in temperature that exceeds its alarm threshold; a callpoint has been activated, etc. Only authorized persons (level 2) can clear these conditions (which may occur after an early warning, pre-alarm, etc.) by means of silence/reset operations. Signaling will continue even after the cause of the alarm has ceased. If the operator does not intervene in the meantime, the point in pre-alarm status will generate an alarm when the programmed pre-alarm time expires. The pre-alarm time is a short alarm delay that notifies the person/s responsible for the safety of the building and its occupants of the possibility of fire. An alarm will be generated when the programmed pre-alarm time expires, thus causing the evacuation of all the building. After pre-alarm notification, the person/s responsible for the safety of the building and its occupants will have time to verify the real risk of fire and, in the event of a false alarm, will be able to avoid unnecessary evacuation signaling. In the event of pre-alarm status generated by the gas detection line, the pre-alarm signal will reset when the gas detector values drop below the pre-alarm threshold.
[O]	FAULT (yellow)	Indicates an active fault condition. The display will provide the fault details.	Indicates a restored fault condition in memory. To view the restored fault condition details, consult the events log using the Main menu (level 1).	To restore the fault memory (return to LED Off status), reset the control panel (level 2).
[P]	CPU FAULT (yellow)	Indicates trouble with the panel CPU; the panel must be sent back immediately to the manufacturer for repair.	Indicates that the CPU re-initialized (due to control panel shutdown or fault condition).	Danger: If this LED "blinks", the efficiency of entire system must be checked. To return to LED Off status, reset the control panel (level 2).

	LED	On solid:	Blinking:	Note
[Q]	DISABLED (yellow)	Indicates that one (or more) of the system components (zone or output) has been bypassed.		The display will provide the respective details. Bypassed components (/disabled/ out-of-service components) will be unable to generate faults, alarms or signals of any sort and cannot be activated under any circumstances. Components must be bypassed (put out-of-service) during maintenance work.
[R]	TEST (yellow)	Indicates that one or more zones are undergoing tests.		A zone which is undergoing tests cannot generate alarms or signaling of any kind. However, the respective LED will turn on for several seconds and then reset and turn off automatically. The ALARM NAC output will activate for approximately 3 seconds to confirm that the detector is working properly. This feature allows technicians to carry out point/zone tests and inspections alone, as it eliminates the need of constantly returning to the panel to verify/reset the events generated by the points.
[S]	ON (green)	Indicates that the system is operating (on).		This LED will go Off in the event of joint primary (230 V ac) and secondary (batteries) power failure.
[T]	DIALLER ON (red)	Indicates that the dialler activation output is active.		The dialler will be activated (after the pre-set delay) in the event of an alarm.
[U]	DISABLE/ FAULT DIALLER (yellow)	Indicates that the dialler activation output is disabled or faulty—the display will provide the respective details.	Indicates restoration of a fault event. This condition can be cleared by reset only (level 2).	
[V]	DISABLE/ FAULT BELLS (yellow)	Indicates that the sounder/flasher activation output is disabled or faulty—the display will provide the respective details.	Indicates restoration of a fault event. This condition can be cleared by reset only (level 2).	
[W]	NIGHT MODE (yellow)	Indicates that the panel is operating in night mode.		For safety reasons, the pre-alarm time of all points is cancelled automatically during night mode (night mode pre-alarm time = 0 seconds). As a further safety precaution, the system can be silenced for the pre-set SILENCE time only. Night Mode should be applied when no or few persons are present or awake in the building, and the building security is the responsibility of a night watchman or security patrol guard notified by the dialler.

Extinguishant module signaling (optional system enhancement tool)

[X]	DISABLE EXTINGUISH	Indicates disablement of all types of extinguish commands, via the appropriate key (paragraph 5.1 - [G]).		
[Y]	DISABLE AUTO	Indicates disablement of automatic extinguish commands, via the appropriate key (paragraph 5.1 - [H]).		

	LED	On solid:	Blinking:	Note
[Z]	DISABLE MANUAL	Indicates disablement of manual extinguish commands, via the appropriate key (paragraph 5.1 - [I]).		
[A1]	EXTINGUISH	Indicates that fire extinction is running.		
[B1]	PRE-EXTINGUISH	Indicates activation of the pre-extinguish output; refer to paragraph 6.13, terminal PRE-EXT.	Indicates that only one zone is in alarm status, therefore, the extinguishant system will not be activated. If another zone latches in alarm, the extinguishant system will be activated.	
[C1]	FAULT	Indicates trouble with the fire extinction circuits.	Indicates restoral of a fault event.	This condition can be cleared by reset only (level 2).
[D1]	STOP EXTINGUISH	Indicates that the fire extinguishant system has been stopped from a remote hold-off unit; refer to paragraph 6.13, terminal STOP-EXT.	Indicates restoral of a Stop extinction event.	
[E1]	CPU FAULT	Indicates a CPU fault that requires immediate repair.	Indicates restoral of a fault event.	

5.2 Repeater (optional system enhancement panel)

Up to four repeater panels can be connected to the RS485 bus. Connected repeater panels replicate all the information provided by the control panel and allow access to all level 1 and 2 functions (view active events, reset, silence, etc. access to the main menu is not possible).



Figure 7 - Front view of the Repeater panel

The SmartLetUSee/LCD-Lite repeater is supported by most control panel models. However, not all the keys/button will work if it is connected to the SmartLine panel. The following keys/buttons will work:

[A]	Navigation keys	Scroll keys which will allow navigation through menus, etc.
[B]	EVACUATE	As per paragraph 5.1
[C]	SILENCE	As per paragraph 5.1
[D]	RESET	As per paragraph 5.1
[E]	INVESTIGATE	As per paragraph 5.1
[F]	BUZZER	Turns the panel beeper off
[G]	TEST	Turns on al the LEDs to verify functionality.

Repeaters provide the following signals.

5.2.1 Display

The display provides same event data as the panel. For further details refer to paragraph 2.5 - *Signaling on display* in the User manual.

5.2.2 LED

	LED	On solid:	On blinking:
[H]	SILENCED	As per paragraph 5.1	
[I]	RESET DISABLED	As per paragraph 5.1	
[J]	INVESTIGATE	Indicates that investigation time has been requested.	
[K]	ALARM	As per paragraph 5.1	
[L]	PRE-ALARM	As per paragraph 5.1	
[M]	FAULT	As per paragraph 5.1	
[N]	CPU FAULT	Indicates that the repeater CPU is not operating properly. If this occurs, the repeater must be sent back to the manufacturer immediately for repair.	
[O]	DISABLED	As per paragraph 5.1	
[P]	TEST	As per paragraph 5.1	
[Q]	NIGHT MODE	As per paragraph 5.1	
[R]	BATTERY	Indicates that the panel batteries are low or inefficient.	Indicates restoral of the low/ inefficient battery event.
[S]	EARTH	Indicates voltage dispersion to earth.	Indicate restoral of the voltage dispersion to earth event.
[T]	FUSE	Indicates protection fuse intervention due to short-circuit on the AUX or AUX-R output.	Indicates restoral of the short-circuit on AUX or AUX_R output event.
[U]	MAINS	Indicates Mains failure.	Indicates restoral of the Mains failure event.
[V]	BELLS - ACTIVE	Indicates that the ALARM NAC output is active.	
[W]	BELLS - FAULT	Indicates that a fault has been detected on the ALARM NAC output.	Indicates restoral of the ALARM output fault.
[X]	BELLS - DISABLED	Indicates that the ALARM NAC output has been disabled.	
[Y]	DIALLER - ACTIVE	Indicates that the DIALER output is active.	

LED		On solid:	On blinking:
[Z]	DIALLER - FAULT	Indicates a DIALER output fault.	Indicates restoral of the Dialer output fault.
[Z1]	DIALLER - DISABLED	Indicates that the DIALER output has been disabled.	

5.2.3 Repeater board

If you open the repeater enclosure, the rear side of the electronic board (which is attached to the frontplate) will be on view. Following is a description of the parts which will be used during the installation phase:

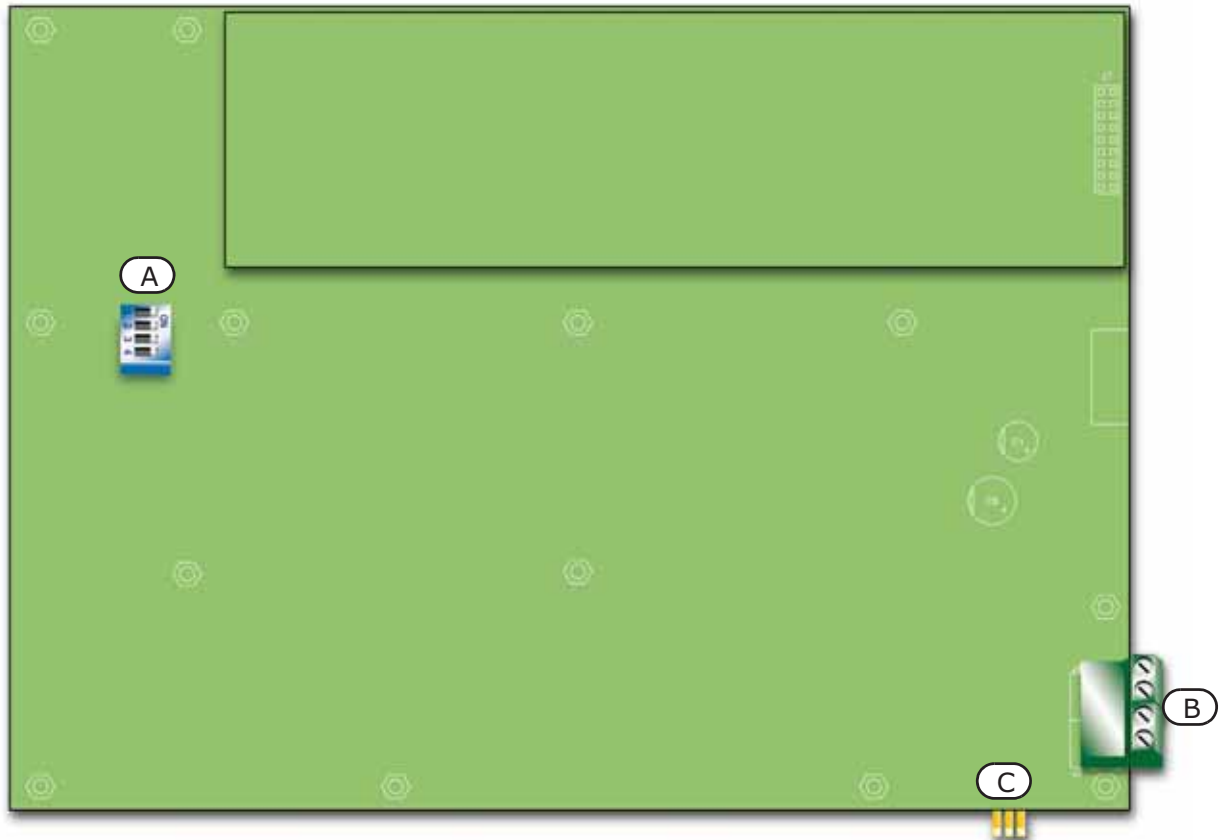

Figure 8 - The rear side of the repeater board

[A]	DIP switches	For the repeater address setting
[B]	RS485 terminals	Respectively, from the bottom of the figure to the top "+24V - + GND", for the connection to the RS485 BUS
[C]	EOL terminals	For the setting-jumper position of the repeater position.

Installation instructions

6.1 Mounting the SmartLine/8Z expansion board (accessory item)

The SmartLine/8Z zone expansion board can be used with the SmartLine020-4 and SmartLine036-4 models. The SmartLine020-4 control panel can manage 2 SmartLine/8Z boards (8 zones each board) bringing the total number of zones to 20, while the SmartLine036-4 control panel can manage up to 36 SmartLine/8Z boards, bringing the total number of zones to 36.

The zone expansion board also provides a 1A supervised output, the operating principles of which can be defined during the system configuration phase.

The extinguishant module is packed in a separate cardboard box. Together with the extinguishant module (IN020), you will find a plastic bag containing:

- Pin header for the extinguishant module to SmartLine motherboard connection
- Mounting plate
- Screws
- EOL resistors and diodes

nr. SmartLine/8Z board	Connections	Zones
1	to SmartLine motherboard	5 - 12
2	to SmartLine/8Z board n.1	13 - 20
3	for SmartLine036-4 only	to SmartLine/8Z board n.2
4		to SmartLine/8Z board n.3

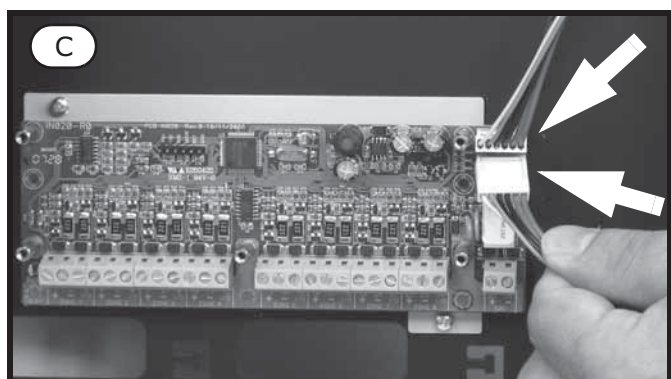
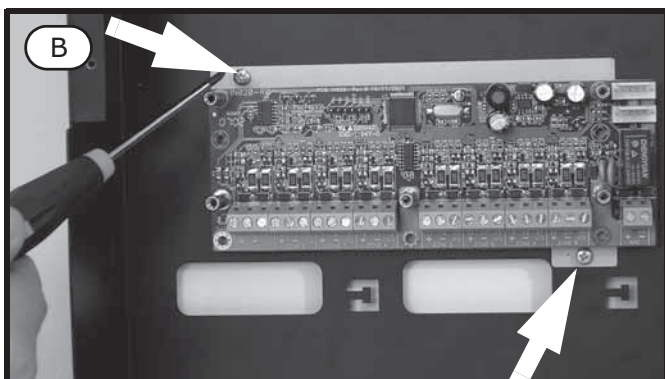
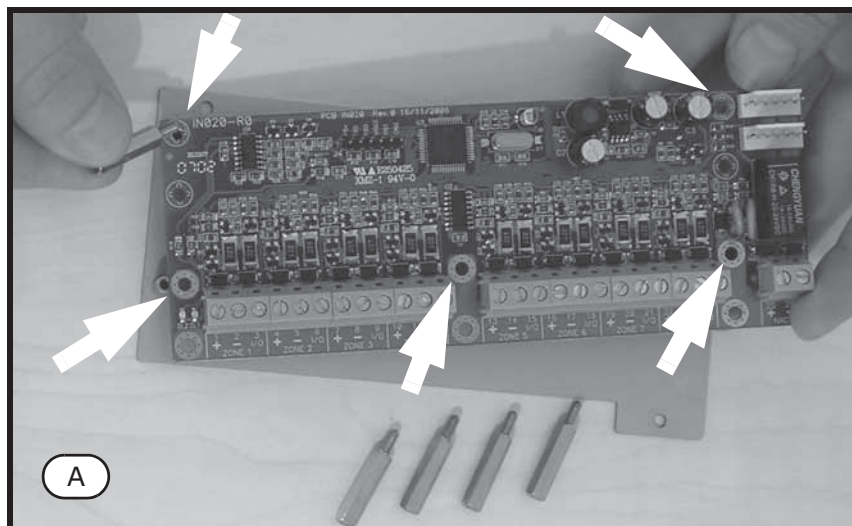

Figure 9 - Mounting the expansion module - 1

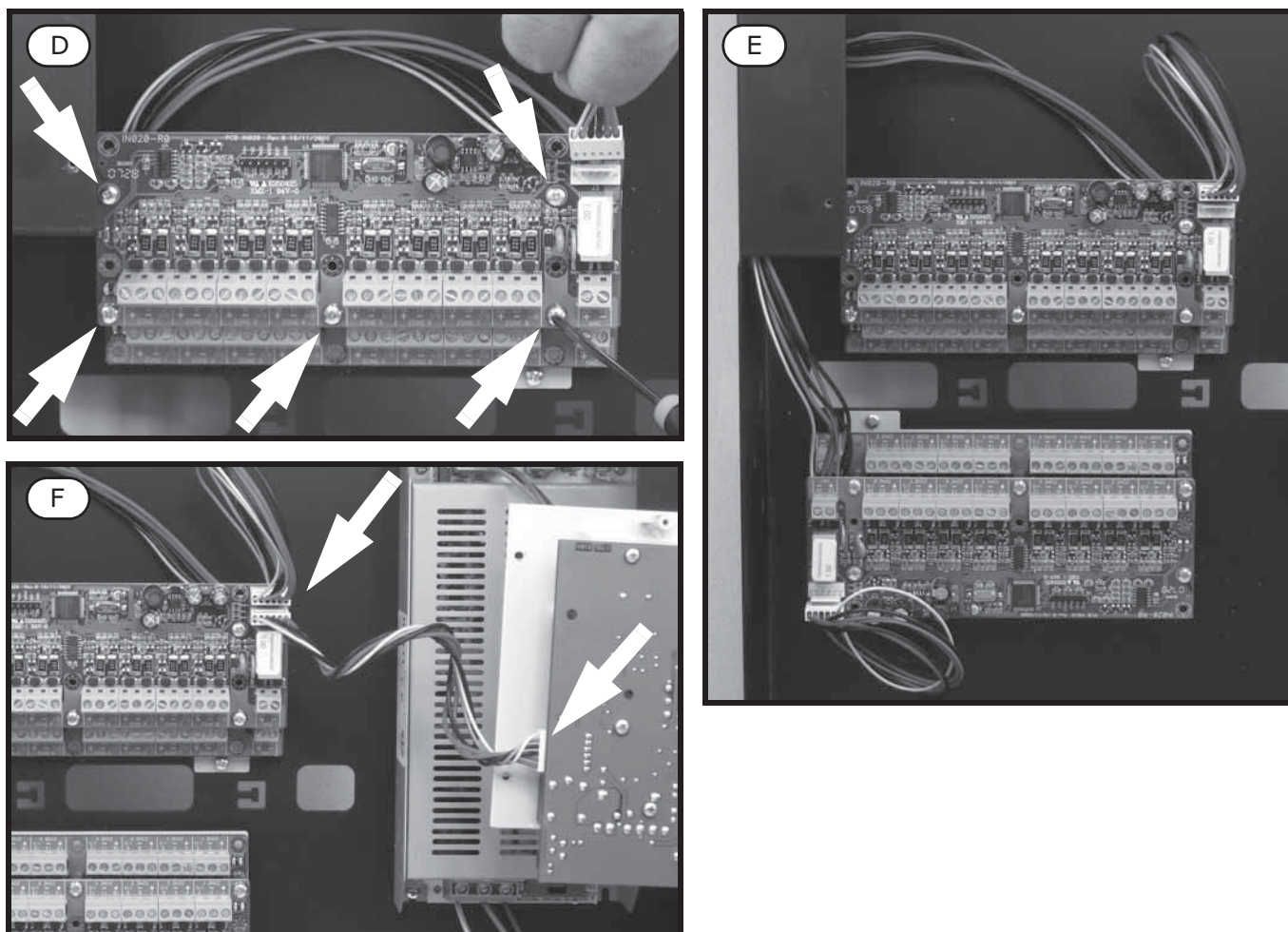

Figure 10 - Mounting the expansion module - 2

1. Remove the four securing screws and the frontplate.
2. Remove the four securing screws and the plastic support.
3. Locate the zone expansion board on the metal plate, using the metal spacers if you are installing two boards (*Figure 9 - [A]*). Be careful to use the mounting holes indicated in the photograph.
4. Position the plate with the expansion board in its location on the backbox (*Figure 9 - [B]*).
5. Plug the expansion board, using the wires to the motherboard and to the next expansion board (*Figure 9 - [C]*).
6. Locate the second zone expansion board on the metal spacers (*Figure 10 - [D]*).
7. Connect the wire from the previous zone expansion board and to the next zone expansion board.
8. Mount on another metal plate and connect each other the third and the fourth boards.
9. Position the second plate board in its location on the backboard.
10. Connect the third to the second board (*Figure 10 - [E]*).
11. Connect the wire coming from the first zone expansion board to the SmartLine motherboard (*Figure 10 - [F]*).
12. Replace the plastic holder and close the control panel cabinet.

Note:

In order to allow the control panel to manage the expansion board, you must include it in the configuration. Refer to the Programming section for details.

6.2 Mounting the SmartLAN/485 ethernet board (accessory item)

The SmartLAN/485 allows you to program the fire-detection panel parameters from remote locations using the SmartLeague software via LAN/internet. Additionally, the SmartLAN/485 is capable of sending a UDP packet (event description report) to a configurable IP address each time the fire-detection panel registers an event.

As a result of this feature, the fire-detection panel can be supervised through INIM's custom software (SmartLook), or integrated into any supervisory software. For further details and for the installation procedure, refer to the manual provided with the board.

6.3 Mounting the SmartLetLoose/ONE extinguishant board (accessory item)

The extinguishant module is packed in a separate cardboard box. Together with the extinguishant module (IN015), you will find a plastic bag containing:

- Pin header for the extinguishant module to SmartLine motherboard connection
- Screws
- EOL resistors and diodes

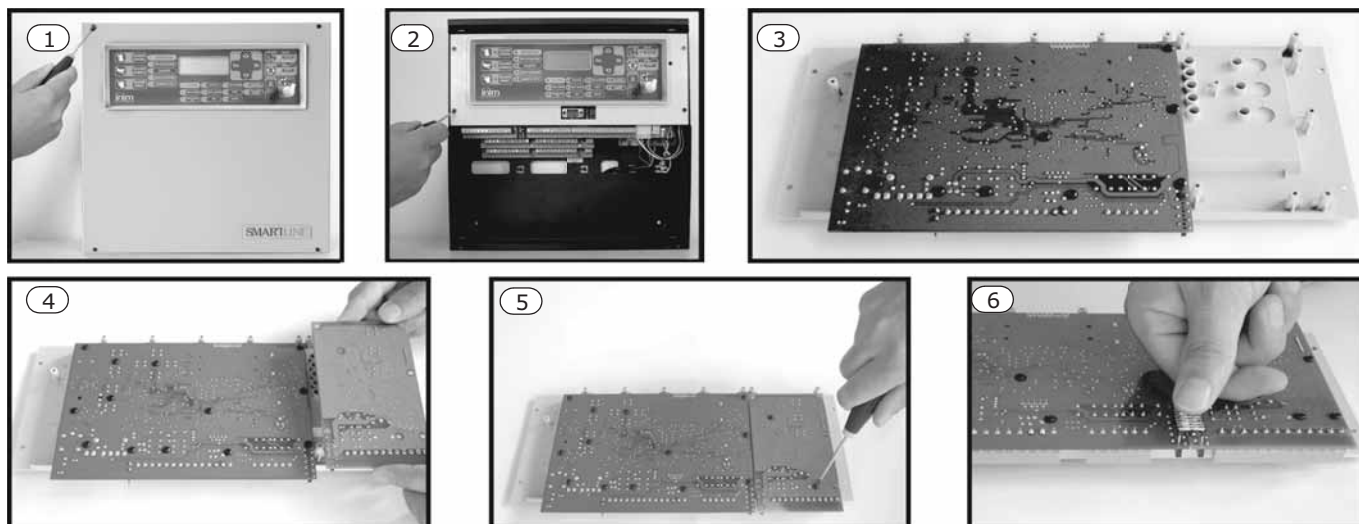

Figure 11 - Mounting the extinguishant module

1. Remove the four securing screws and the frontplate.
2. Remove the four securing screws and the plastic support.
3. Position the SmartLine motherboard as shown in the figure.
4. Locate the extinguishant module in its housing.
5. Using the four screws, secure the extinguishant module in position.
6. Connect pins J13 of the SmartLine motherboard (paragraph 4.1 - [R]) to the respective pins J2 on the extinguishant module.
7. Move the SmartLine motherboard back to its original position.
8. Replace the plastic support.

Note: *In order to allow the control panel to manage the connected extinguishant board, you must include it in the configuration. Refer to the Programming section for details.*

6.4 Wall mounting

6.4.1 Control panel

1. Pull the wires through the wire entry and ensure they do not get in way of operations.
2. Using the wall plugs, attach the backplate to the wall.

Danger: **Care must be taken not to drill in the vicinity of electrical wiring, heating ducts and plumbing.**

6.4.2 SmartLetUSee/LCD-Lite repeater (accessory item)

1. Remove the four frontplate screws and lift off the frontplate.
2. Pull the wires through the wire entry on the back of the repeater and ensure they do not get in way of operations.
3. Using the wall plugs, attach the backplate to the wall.

6.5 Connecting the lines

6.5.1 Connecting the detection lines

Each control panel zone has a pair of detector or callpoint connection terminals (detection line).

Attention: In order to validate the IMQ-SECURITY SYSTEMS, NOT more 512 detectors and/or manual callpoints can be connected.

The following diagrams illustrate the detection line wiring of the IRIS devices from INIM (see Appendix A - *Iris devices*):

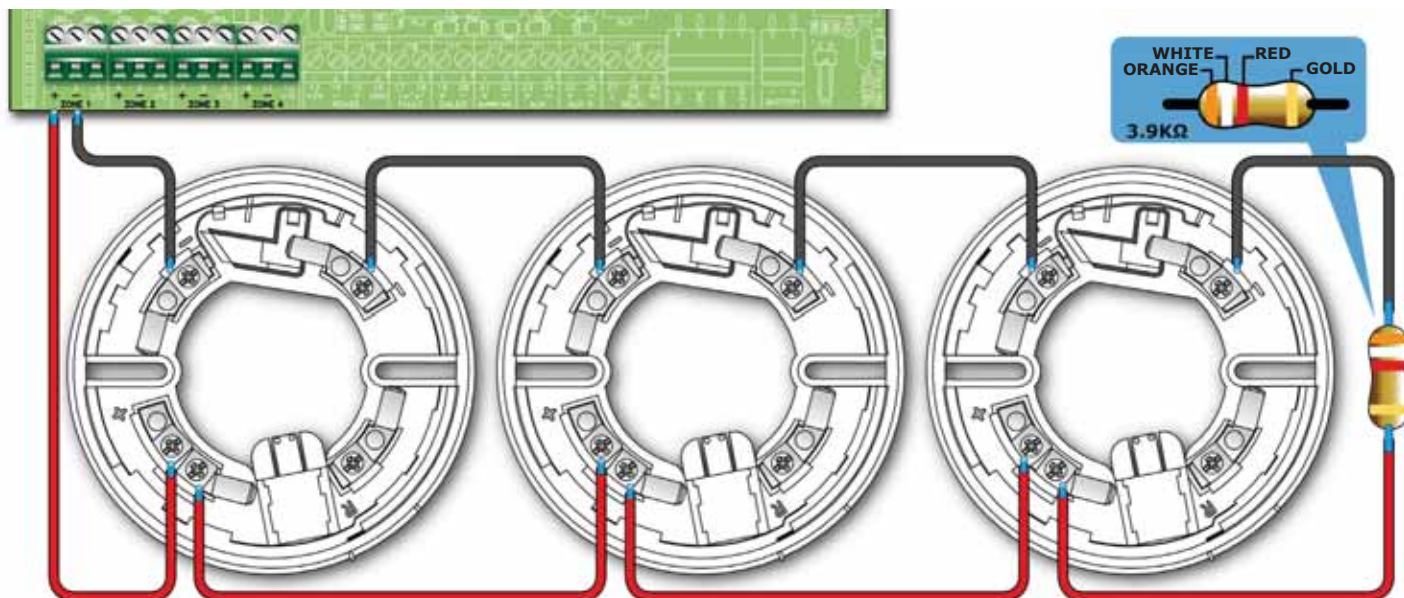

Figure 12 - Connecting Iris detectors

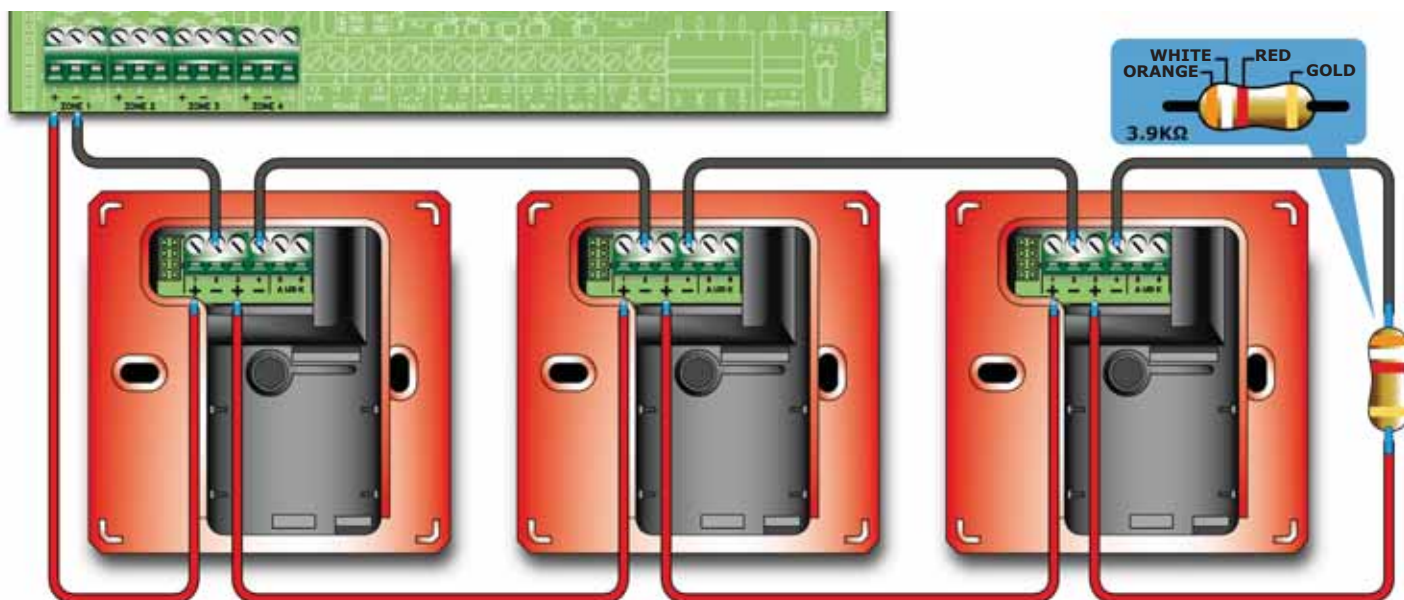

Figure 13 - Connecting Iris callpoints

If detectors and callpoints are wired as per the diagram and the zone "Monitor Callpoints" option is enabled, the control panel will discriminate between detector and callpoint triggered alarms.

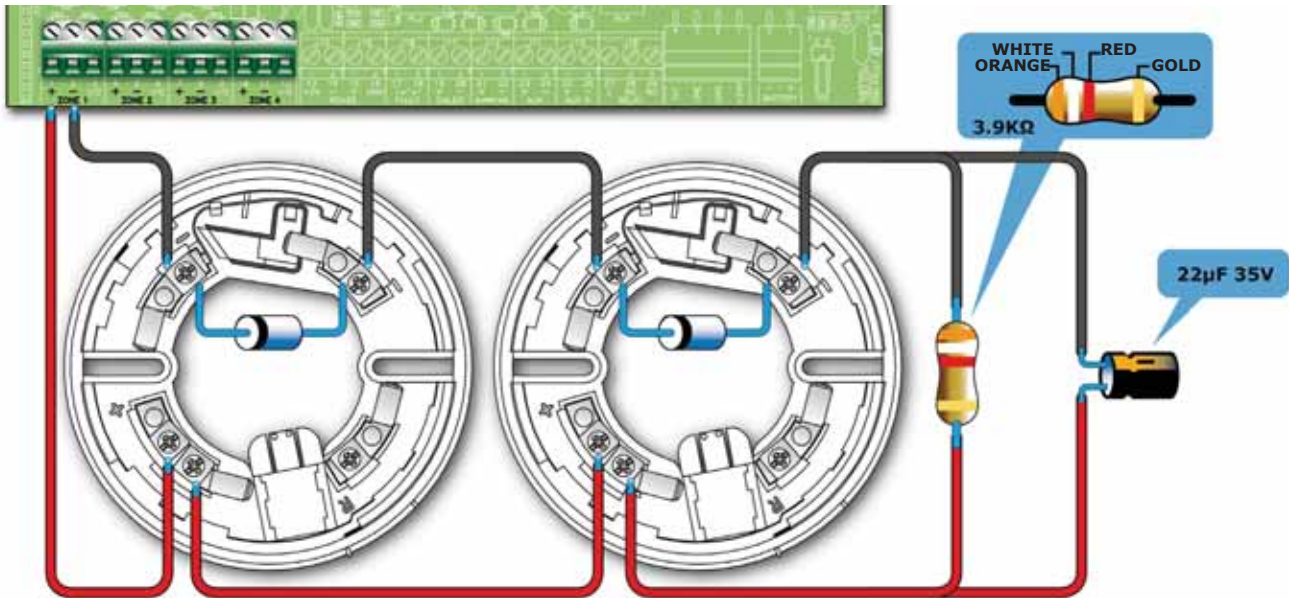

Figure 14 - Wiring for detection with missing detectors

If detectors are wired as per the diagram and the “Det.Missing” option is enabled, the control panel will generate a fault signal when a detector is removed from its base and at the same time will be able to receive alarm signals from other detectors connected downstream.

Attention: If you enable the “Det.Missing” option for a zone that is not wired as illustrated in the figure, the control panel will signal fault only.

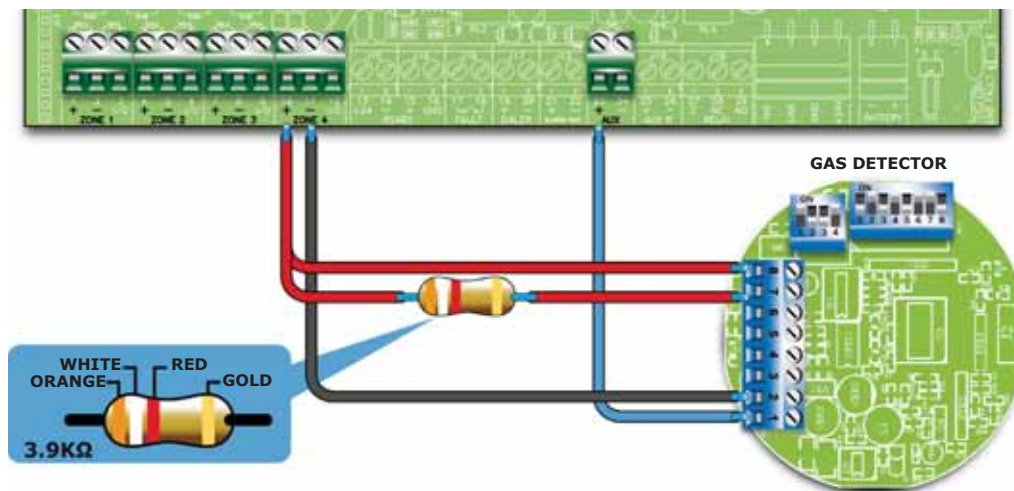

Figure 15 - Connecting gas detectors to the detection line

If the wiring is completed as per the diagram, it will be possible to interface the control panel with a gas line (line configured as a GAS line; refer to the zone programming section).

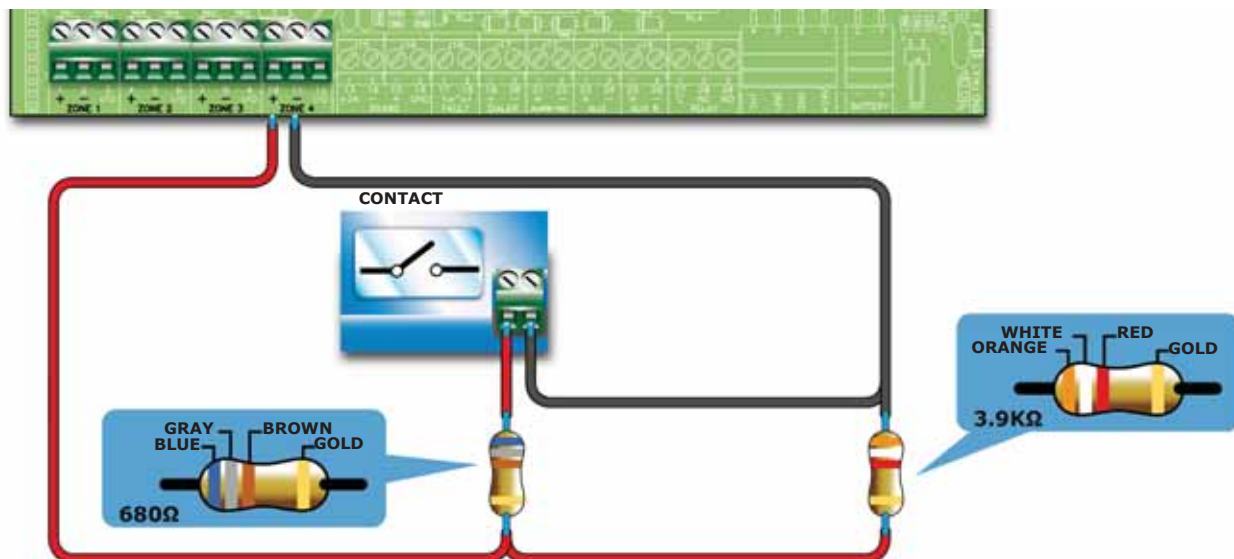

Figure 16 - Connecting generic contacts to the detection line

The wiring diagram above illustrates the connection of a generic device (callpoint, switch, generic device output) to the detection line. If the line is wired in this way, it will signal a fault if a short-circuit or cable interruption occurs, and will generate the pre-set line signals (alarm, sprinkler, change class, etc.) if the contact closes.

6.5.2 Connecting I/O Lines

Each zone I/O line can be wired in one of the following ways:

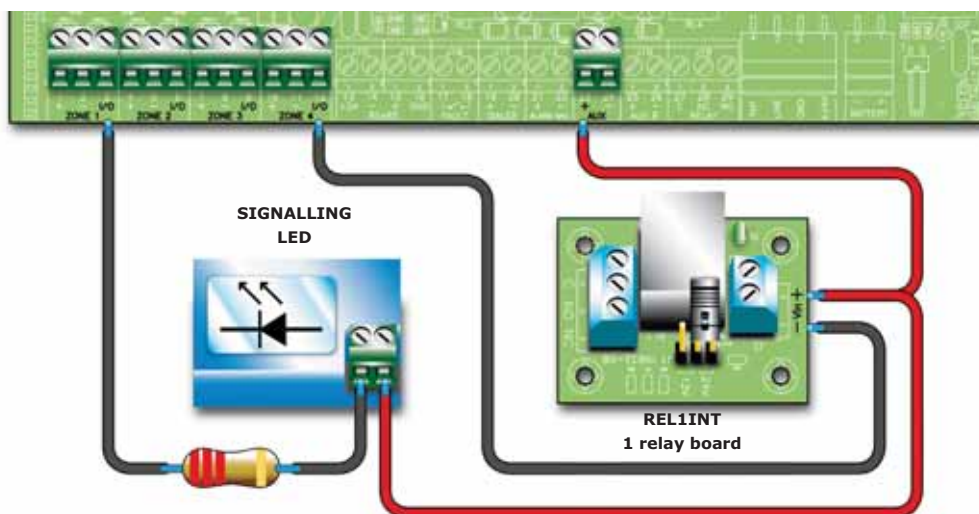

Figure 17 - Wiring the I/O line as an output

The diagram above illustrates a line wired as an output. The terminal will operate in the same way as an open-collector output, that is, it will be open during standby status and close to Ground (-) in the event of activation.

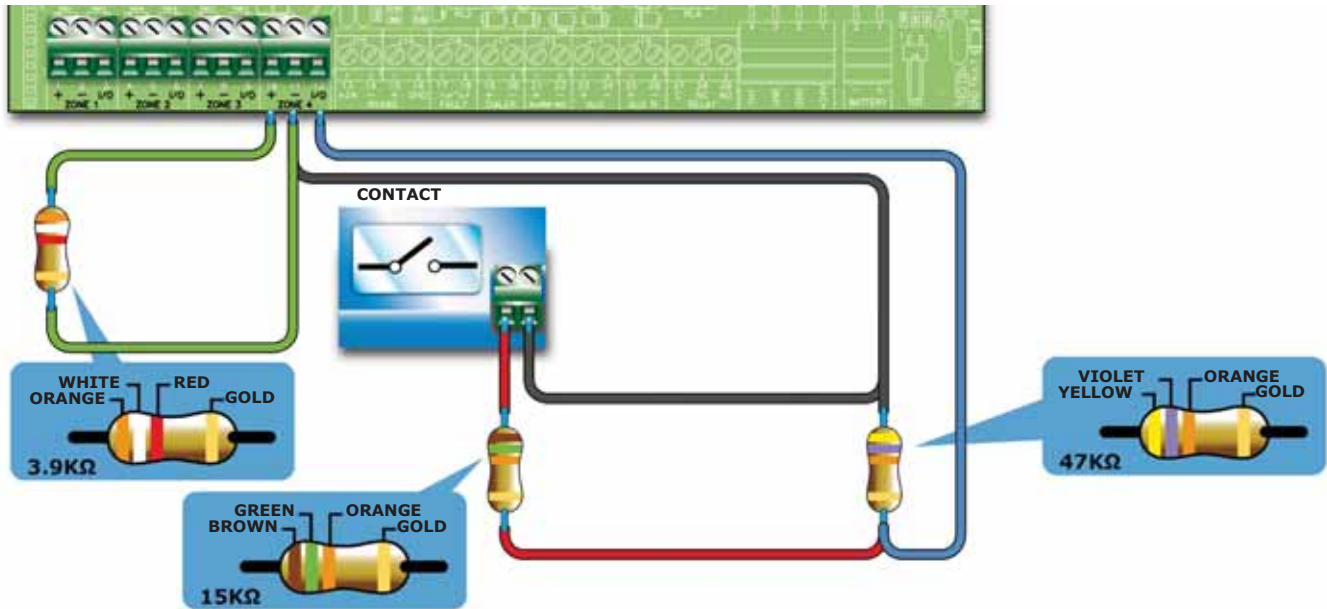

Figure 18 - Wiring the I/O line as an input

The diagram above illustrates a line wired as an input. The EOL resistor will allow the control panel to supervise the wiring, and the resistor connected in series to the activation contact will allow it to discriminate between an activation signal and short-circuit.

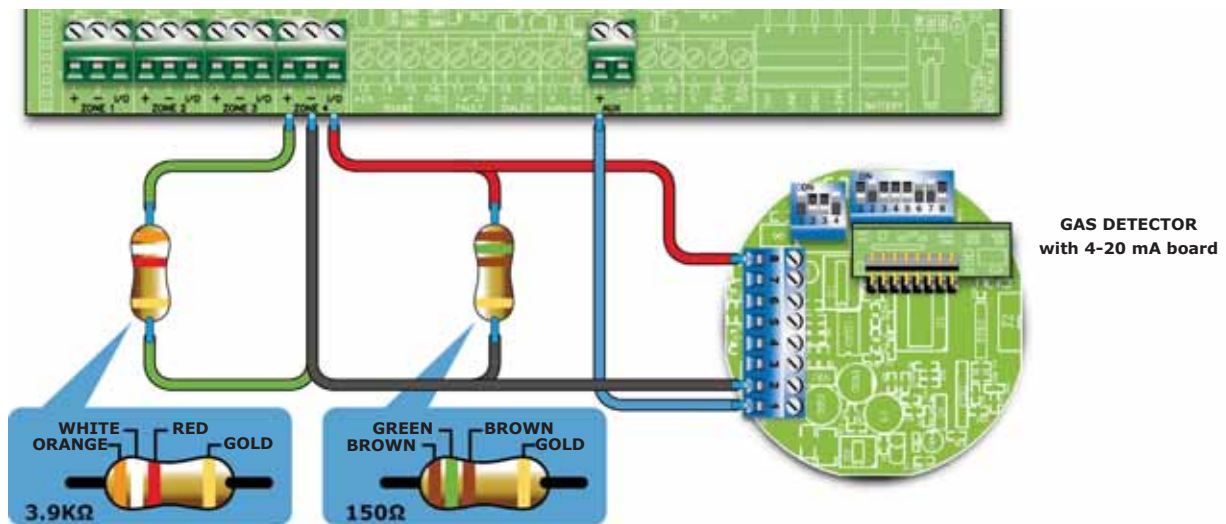

Figure 19 - Connecting 4-20 mA gas detectors

The diagram above illustrates a I/O line wired as a 4-20mA gas input, this wiring method allows the line to interface with a 4-20mA gas detector.

During the installation of the gas detector, it is recommended to insert the 4-20 mA board as shown in figure, with the components side opposite the DIP switch.

Note: *In order to validate the IMQ-SECURITY SYSTEMS certification, this output should not be used as a type C, E or J output (EN 54-1), and must not be used to command Fire-alarm or Fault transmission devices.*

6.5.3 Wiring

1. Use 2 pole cable with Fire code compliant flame class.

Note: *In order to validate the IMQ-SECURITY SYSTEMS certification: the total number of fire detectors and/or manual callpoints connected to a zone using the split method (terminals + with - and I/O with -), must not exceed 30 units; the maximum wire length must not exceed 3000m and the wire resistance must not exceed 100 ohm.*

2. Fire alarm wires must be separate from other power wiring circuits.
3. All cabling, connections and junctions should be completed using the local country Fire Code compliant method.

6.5.4 Fire code guidelines

Danger: **All circuits should be wired using the local country Fire Code compliant method.**

6.6 Connecting the Dialer

The panel dialer must have an activation terminal that will generate calls when it connects to GND (activation -A).

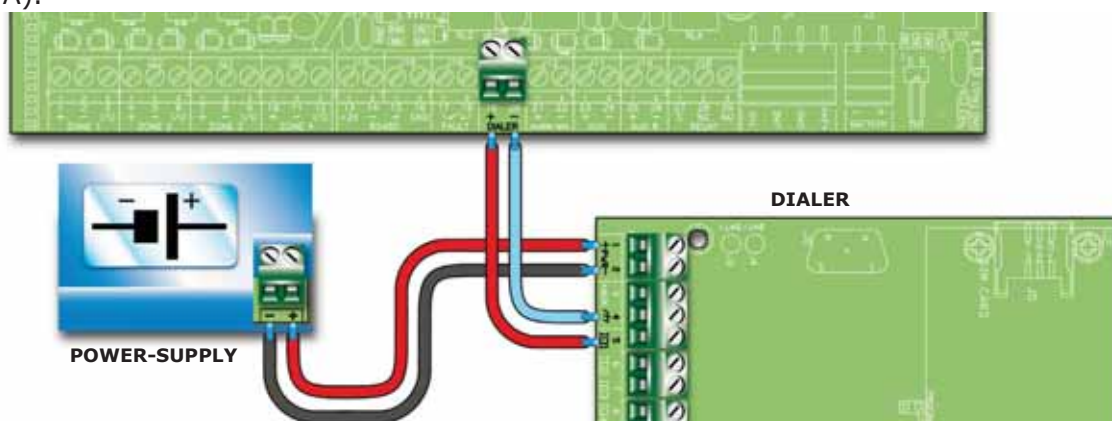

Figure 20 - Connecting the Dialer

6.6.1 Wiring

1. Connect the telephone dialer to the *DIALER* terminals.
2. Connect a 10 kΩ resistor to the dialer, as shown in the previous figure. This resistor will monitor the integrity of the connection between the panel and the dialer and will signal any short-circuits or interruptions.

In the event of an alarm, the panel will trigger the dialer which, after the programmed delay, will send the respective calls to pre-set telephone numbers.

Note: *If you do not connect a dialer, the control panel +DIALER output should be connected to the +AUX output by a 10 kΩ resistor.*

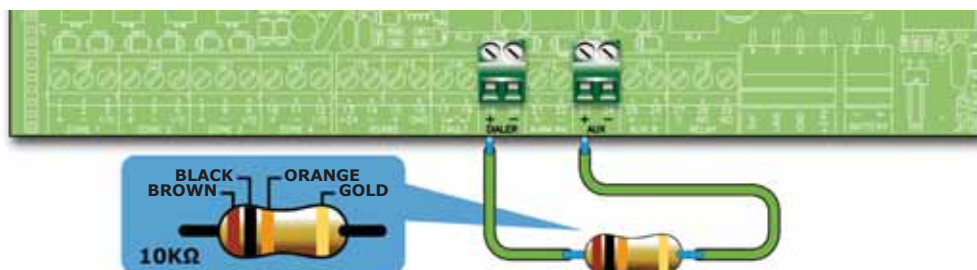

Figure 21 - +DIALER output connection without dialer

6.7 Connecting the RS485 BUS

The RS485 BUS terminals accept up to 4 SmartLetUSee/LCD-Lite repeaters (remote information points, generally located in the entrance areas of the protected building) and 2 SmartLevel power stations.

The devices must be connected in parallel. The panel communicates with the repeater panels using a highly noise-immune digital protocol.

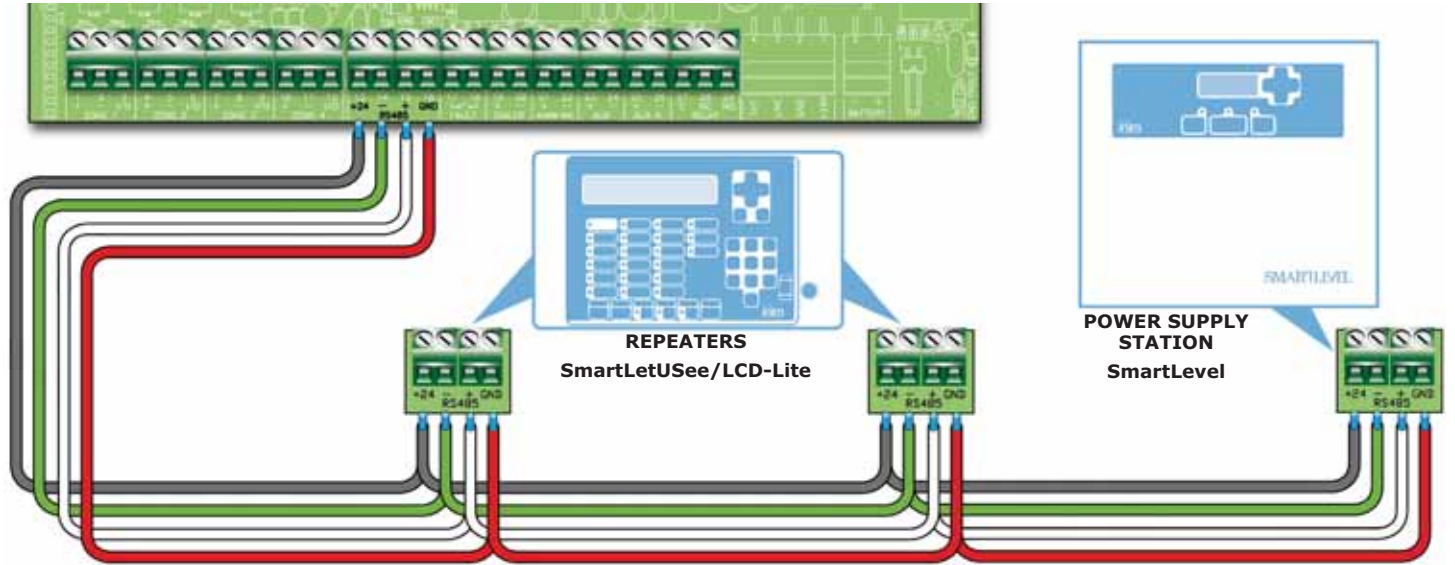

Figure 22 - Connecting the RS485 BUS

6.7.1 Wiring

1. Use a 4 pole STP cable.
2. The cable length between the panel and repeater should not exceed 1000 m.
3. Connect the shield to earth (terminal 6 can be used for this connection).

6.7.2 Setting the addresses of devices connected to the RS485 BUS

1. Each of the devices connected to the RS485 BUS must have a distinct address. When setting the addresses of SmartLevel devices, refer to the Power Station programming manual. When setting the addresses of repeaters, use the DIP switches (paragraph 5.2.3 - [A]).

Address	1	2	3	4
DIP Switch position				

Attention: All other DIP switch configurations are NOT allowed.

2. Ensure that the EOL jumper (paragraph 5.2.3 - [C]) is set in the EOL position on the last device on the line ONLY.

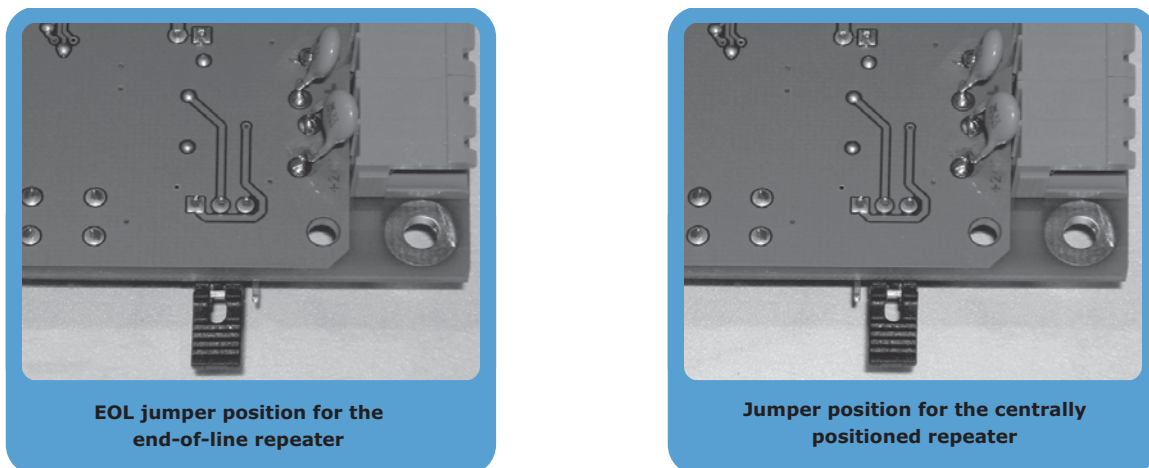

Figure 23 - SmartLetUSee/LCD-Lite board - jumper position

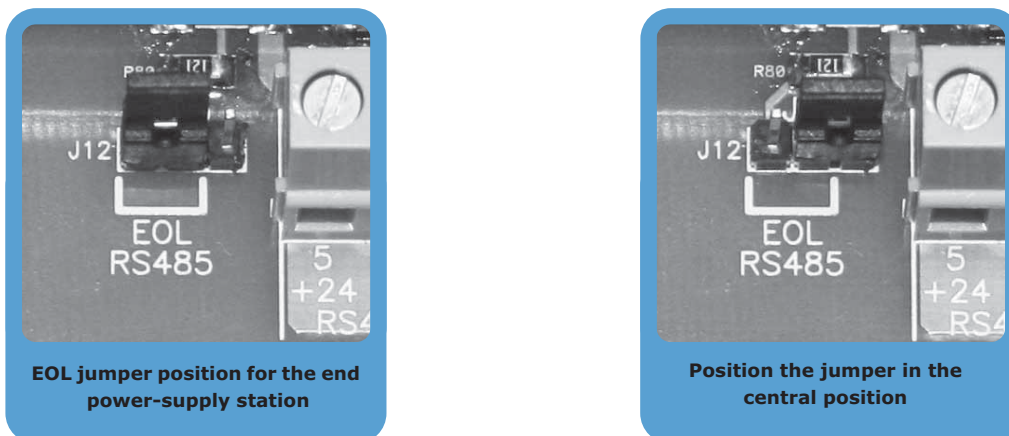

Figure 24 - SmartLevel board - jumper position

6.8 Connecting the fault signaling outputs

The control panel provides a Fault signal output (normally open, non-supervised contact).

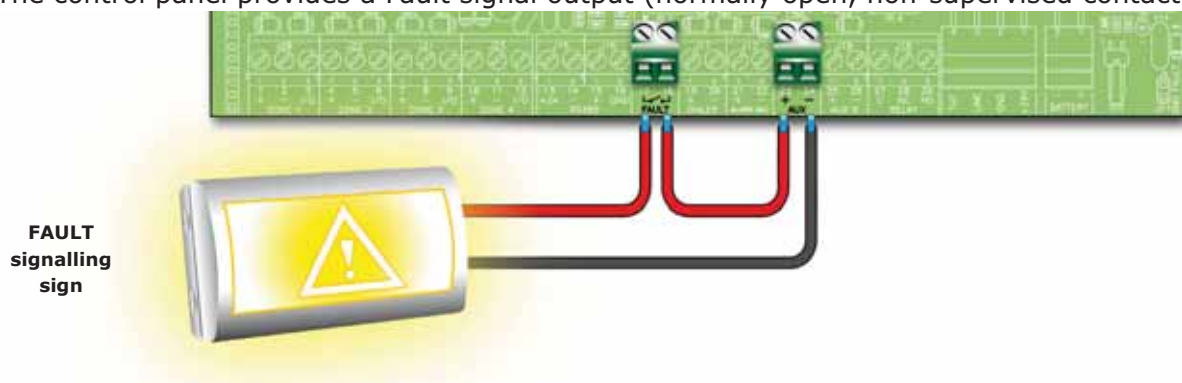

Figure 25 - Connecting the fault signal output

During standby status, the 2 terminals will be open. If the control panel detects any type of fault, the two terminals will close together. The contact can switch a maximum load of 1A - 30V.

Note: *In order to validate the IMQ-SECURITY SYSTEMS certification, this output should not be used as a type C, E or J output (EN 54-1), and must not be used to command or Fault transmission devices.*

6.8.1 Wiring

Use NON-shielded cable. The wire section should be compatible with the wire length and load connected.

6.9 Connecting the Alarm signaling output

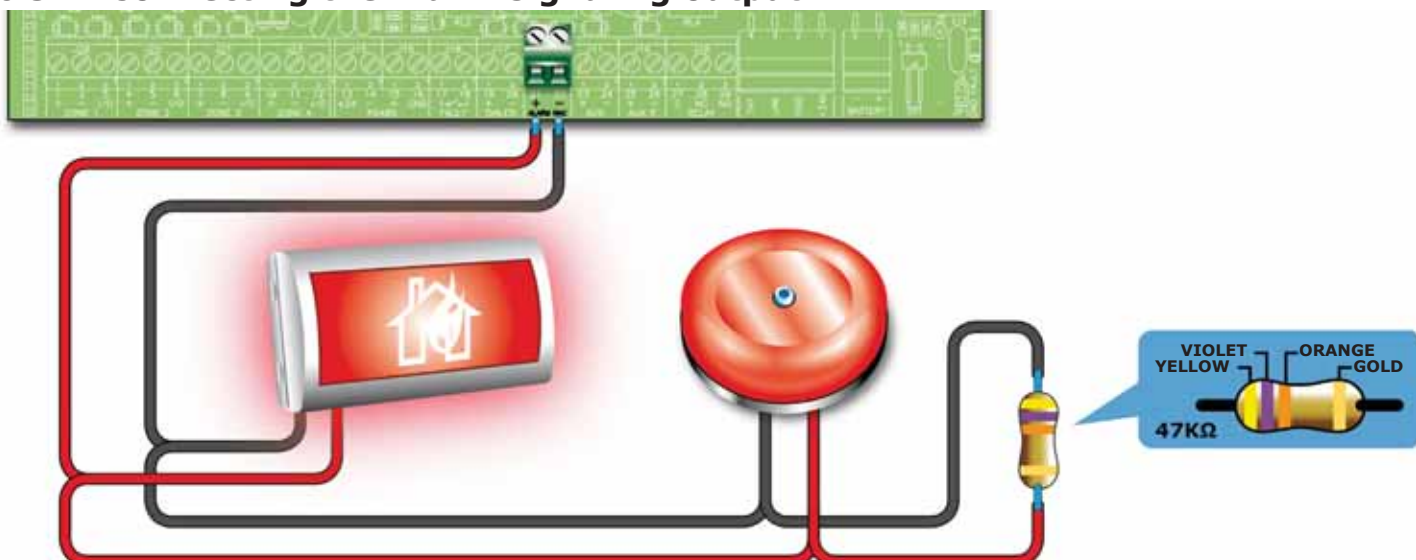

Figure 26 - Connecting the Alarm output

The alarm output is a silenceable supervised output protected by a resettable fuse @ 0.9 A.

During standby status the panel will allow a low supervisory current to circulate on the line with reverse polarity to that indicated on the board. The diodes connected in series to each load on the line will ensure that the current closes on the EOL resistor. This current allows the panel to verify cable integrity. Open or shorted conditions on the wires will generate a fault signal: "Open" or "Shorted alarm output".

In the event of an alarm, the output will activate and the panel will supply 24 V in accordance with the polarity indicated on the board.

6.9.1 Wiring

1. Use NON-shielded cable. The wire section should be compatible with the wire length and load connected to the output.
2. Connect the EOL resistor (47 K Ω) in parallel to the last device on the line.
3. Connect a 1N4007 diode (or equivalent) in series to each load.

6.10 Connecting NAC outputs to the Smart/8Z expansion board

The NAC outputs on the expansion boards are programmable, supervised outputs protected by a resettable 0.9 A fuse.

During standby status the panel will allow a low supervisory current to circulate on the line with reverse polarity to that indicated on the board. The diodes connected in series to each load on the line will ensure that the current closes on the EOL resistor. This current allows the panel to verify cable integrity. Open or shorted conditions on the wires will generate a fault signal: "Open" or "Shorted alarm output".

In the event of an alarm, the output will activate and the panel will supply 24 V in accordance with the polarity indicated on the board.

Note: *In order to validate the IMQ-SECURITY SYSTEMS certification, and to comply with type C outputs, thus suitable to command Fire Alarm signaling devices, these outputs must be programmed to activate only in the event of fire. Furthermore, they should not be used as type E or J outputs (EN 54-1) and consequently should not be used to command Alarm or Fault transmission devices.*

6.10.1 Wiring

Refer to paragraph 6.9.1 - *Wiring*.

6.11 Connecting AUX and AUX-R outputs

6.11.1 AUX output

The AUX output supplies 24V (27.6V), 0.9A current (maximum) power source for external devices. The output is protected by a resettable fuse @ 0.9 A.

In the event of short-circuit, the panel will signal a fault.

6.11.2 AUX-R output

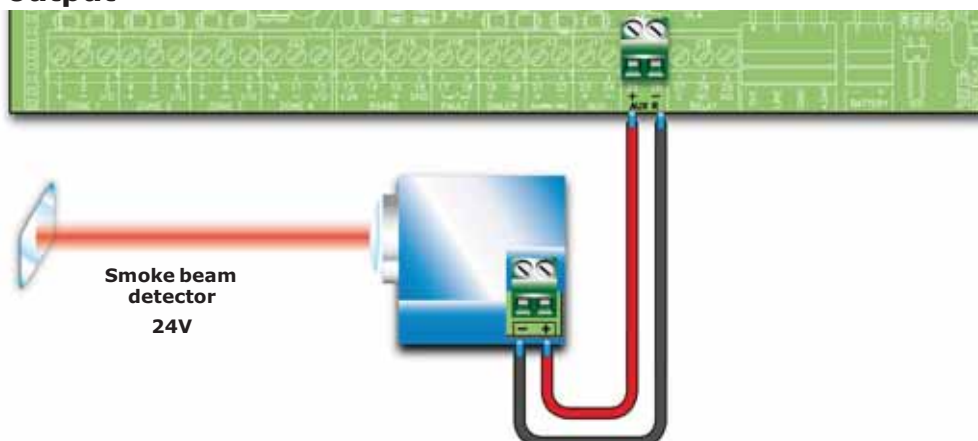

Figure 27 - Connecting AUX-R output

The AUX-R output supplies 24V (27.6V) and 0.9A current (maximum) that is removed during reset, and therefore can be used as a power source to beam detectors, that once latched in alarm must be switched off in order to reset to standby status.

The AUX-R output can be wired to activate/deactivate as a consequence of different conditions (refer to the Programming section).

6.11.3 Wiring

Use NON-shielded cable. The wire section should be compatible with the wire length and load connected.

6.12 Connecting RELAY output

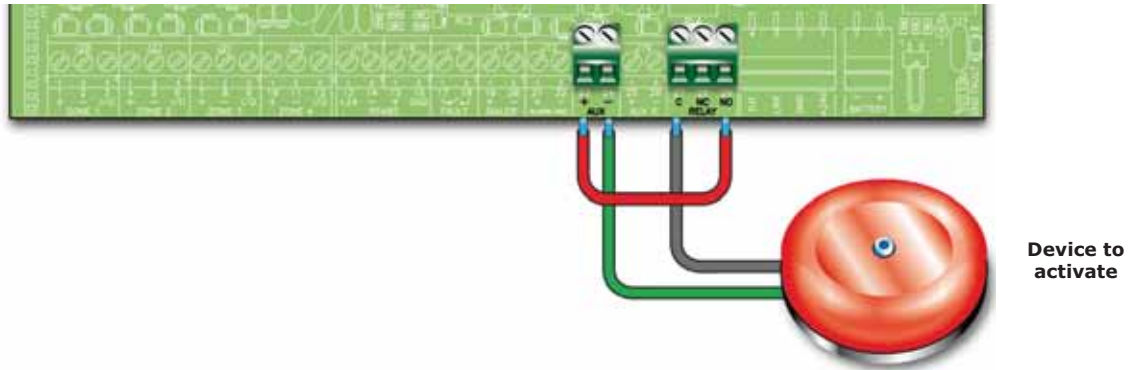

Figure 28 - Connecting RELAY output

The RELAY output provides a dry contact that can switch 1A 30V loads. At default the relay is configured to activate in the event of an alarm but can be configured to activate in the event of various conditions.

Note: *In order to validate the IMQ-SECURITY SYSTEMS certification, this output should not be used as a type C, E or J output (EN 54-1), and must not be used to command Fire-alarm or Fault transmission devices.*

6.12.1 Wiring

Use NON-shielded cable. The wire section should be compatible with the wire length and load connected.

6.13 Connecting the Extinguishant module (optional system enhancement tool)

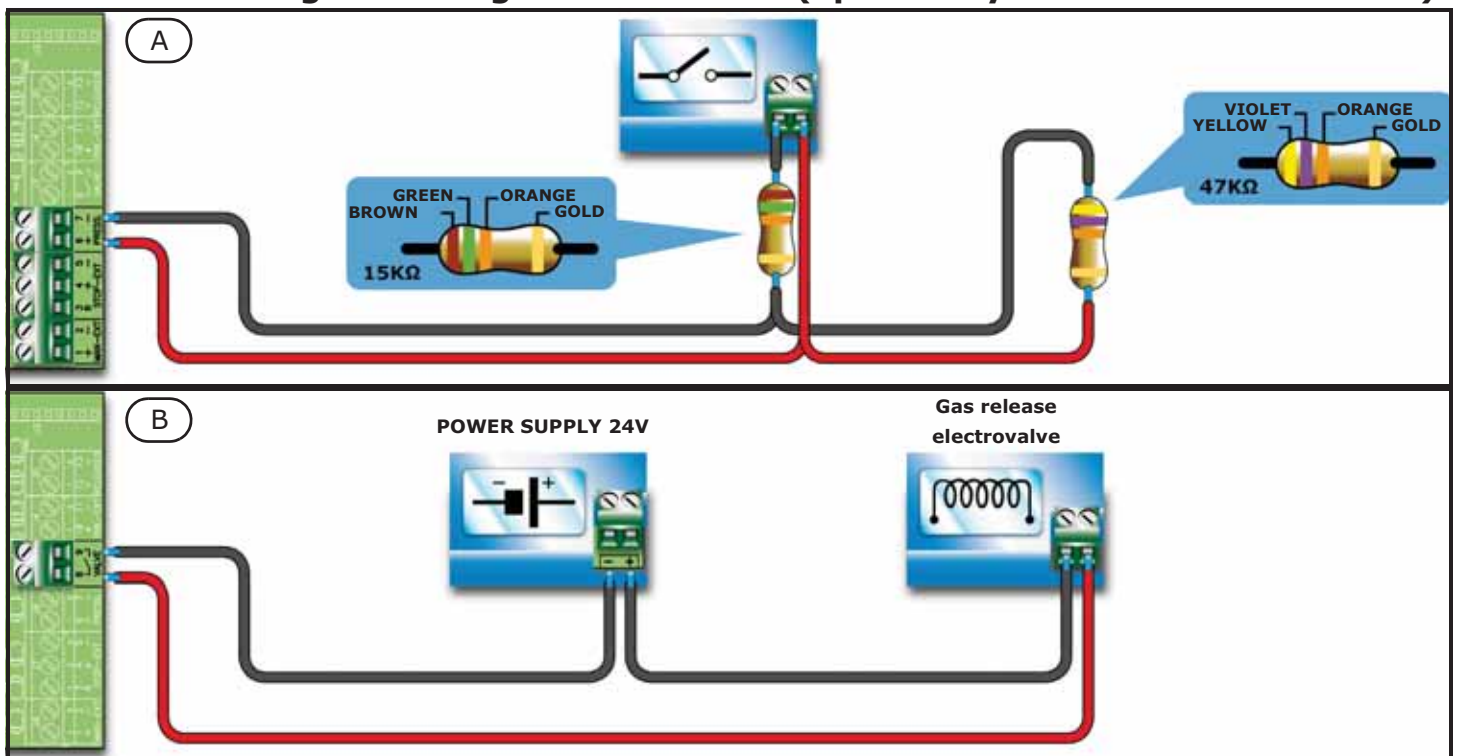

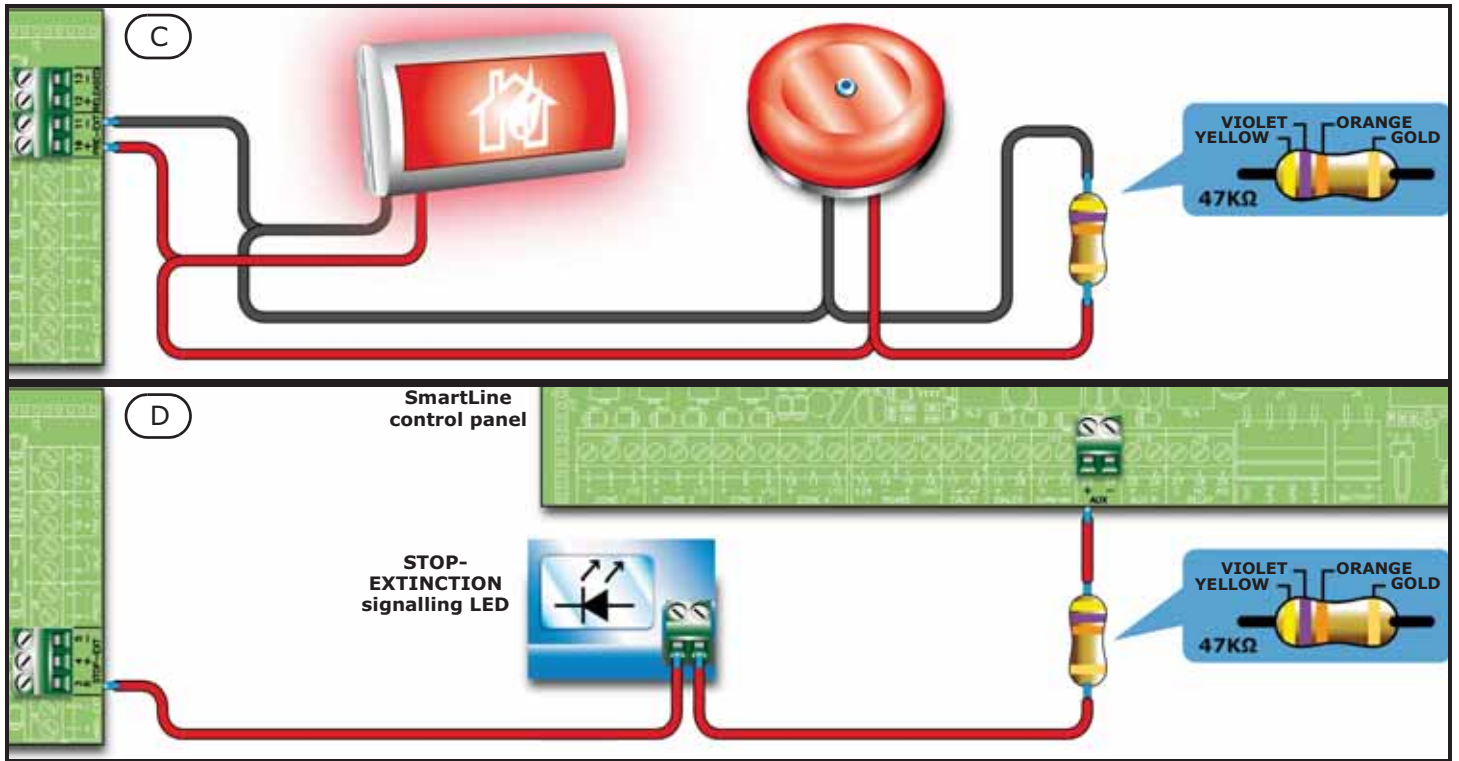

Figure 29 - Extinguishant module

6.13.1 Inputs

Terminal	Device to be connected	Input Type	Note	Wiring Diagram
MAN-EXT	Extinguishment system Start button	Supervised.	Up to 20 devices can be connected to this input.	Figure 29 - Extinguishant module/A 47K = Standby 15K = Active
STOP-EXT	STOP extinguishment-system button	Supervised.	The STOP extinguishment-system button should always be located near to the protected area. This will allow any persons present during the release of extinguishment gas to stop the process and evacuate the area unharmed. Up to 20 devices can be connected to this input.	
PRESS	Gas extinguishment pressure switch.	Supervised.	The pressure switch has two functions: - Under normal operating conditions, it monitors the pressure of the Gas extinguishment. If the pressure drops spontaneously below the pre-set value, it will generate a fault signal. - After an 'Extinguishment' command, it confirms that the command has been executed.	

6.13.2 Outputs

Terminal	Device/s to connect	Output Type	Note	Wiring Diagram
VALVE	Electrovalve for gas release.	Supervised		Figure 29 - Extinguishant module/B

Terminal	Device/s to connect	Output Type	Note	Wiring Diagram
PRE-EXT	Audible and Visual signaling devices	Supervised	The signaling devices activate as soon as the detectors sense fire conditions that require gas extinguishant intervention. This will allow building occupants to evacuate the building before the gas extinguishant is released. The delay between the activation of alarm signaling devices and the release of the gas extinguishant is customizable.	Figure 29 - <i>Extinguishant module/C</i> 47K Balancing
RELEASED	"Extinguishant Gas release" signaling devices	Supervised	There are two activation modes: - activation on confirmation of Extinguishant Gas release; - simultaneous activation with the electrovalve output. This mode requires gas detectors in the protected environment.	
R	Remote LED that signals the deployment of the STOP extinguishant-system button.	Open Collector (non-supervised)	Activates (closes to GND) in the event of activation of the STOP EXT input (max 100 mA).	Figure 29 - <i>Extinguishant module/D</i>

6.14 Connecting the Mains

The switching power supply module (housed inside the box under the motherboard) provides the power source to the entire system and recharges the batteries.

The panel must be connected to a separate line on the electrical switch board. The line must be protected by a fire code compliant sectioning device.

The protective earthing system must be compliant with the local safety regulations, fire code, laws and bylaws in force.

6.14.1 Technical specifications

Primary power source: 230 V ac (-15% + 10%) 50/60 Hz

Panel current draw: 0.5 A (max.)

6.14.2 Wiring

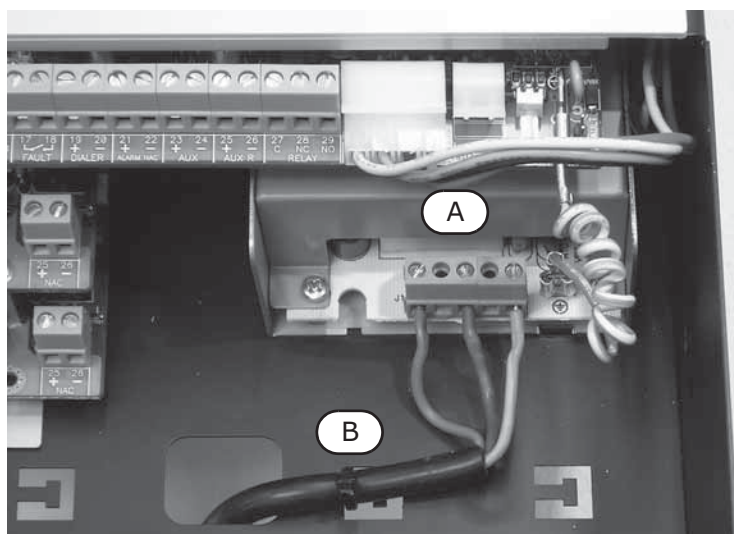

Figure 30 - Connecting the Mains

Danger: Switch off the mains power before starting the mains connections.

1. Connect the wires to the terminal board [A] of the power supply.
2. Using a plastic cable tie, secure the cable to the hook [B] on the back of the control panel.

Attention: **Wiring circuits must not be commingled without proper separation. Adhere to the connection wiring in the diagram.**

6.15 Connecting the batteries

The panel box provides housing for two 12 V-7 Ah lead batteries. The two batteries must be connected in series, in such way as to provide a 24 V current.

Using the connection wires (included), connect the batteries together and then connect the batteries to the SmartLine control panel. The actual connection must be completed during the process described in paragraph 7.3 - *Powering up the system*.

The batteries are the secondary power supply of the system. Once powered up, the panel will charge and monitor the batteries automatically. The battery monitoring process is as follows:

- **Efficiency test**

The panel checks the efficiency of the batteries by simulating load current demand at regular 60 second intervals. If the batteries fail to meet the load current demand, the event will be signaled on the "Battery disconnected" fault LED.

- **Battery level test**

In the event of mains failure, the panel continuously monitors the battery voltage. If it drops below 22.8 V, the panel will signal the event on the "Low Battery" LED. The event will end when the voltage restores to 24.6 V.

- **Deep discharge shutdown**

If a mains failure event lasts for a long period, and battery voltage drops below 18 V, the panel will shutdown the batteries automatically in order to avoid irreparable damage.

6.16 Thermal Probe

Attention: **In order to validate the IMQ-SECURITY SYSTEMS certification and comply with EN 54-4 requirements, installation of a thermal probe is essential.**

The battery has an on-board connector for a thermal probe (accessory item). This device will regulate the charging process in accordance with the battery temperature. The thermal probe protects against battery overheating and consequent permanent damage.

6.16.1 Connecting a thermal probe

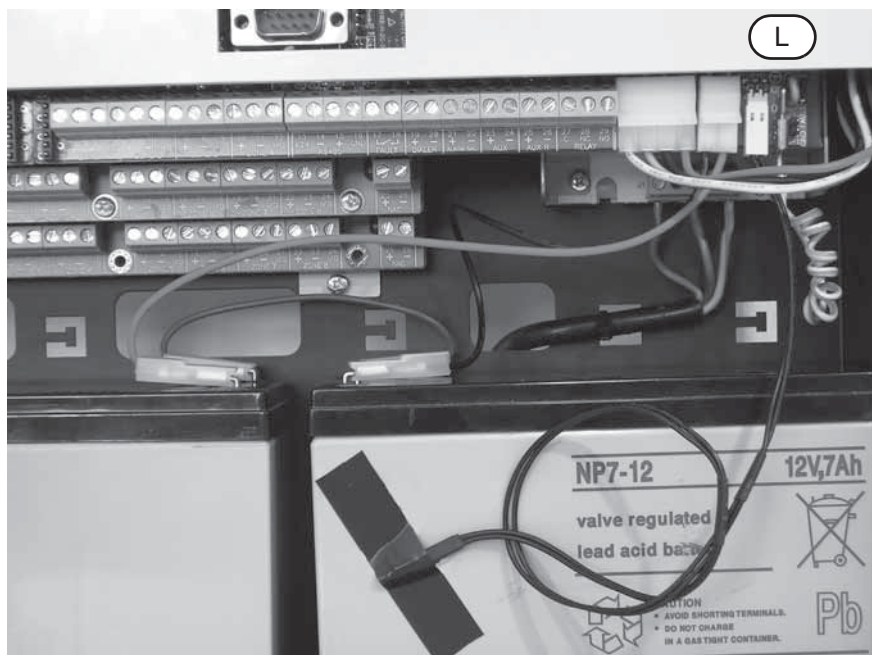

Figure 31 - Connecting a thermal probe

1. Disconnect the batteries (if already connected).
2. Connect the thermal probe to the connector (paragraph 4.1 - [L]).
3. Using adhesive-insulating tape, attach the thermal probe to one of the batteries, in order to provide optimized heat-transfer measurements.
4. Hold a thermometer against the probe, and measure the probe temperature.
5. Using the following graph, find the value the measurement will be based on.

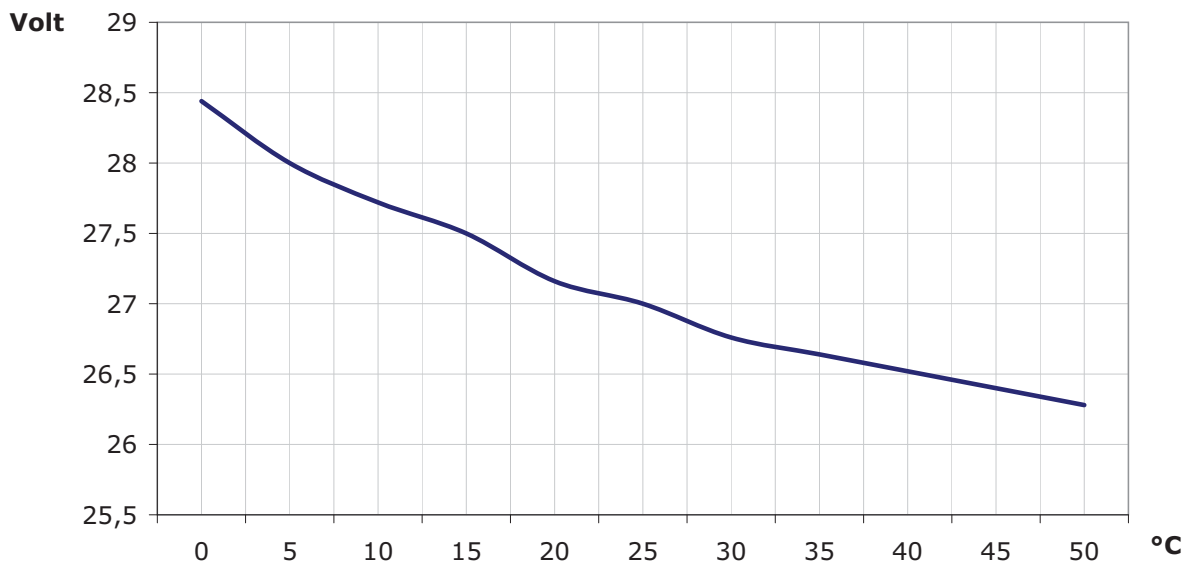

Figure 32 - Voltage charge in relation to the Battery Temperature.

6. Using a tester, measure the voltage on the AUX [A] (paragraph 4.1 - [G]) and turn the trimmer [B] to the previously measured value.

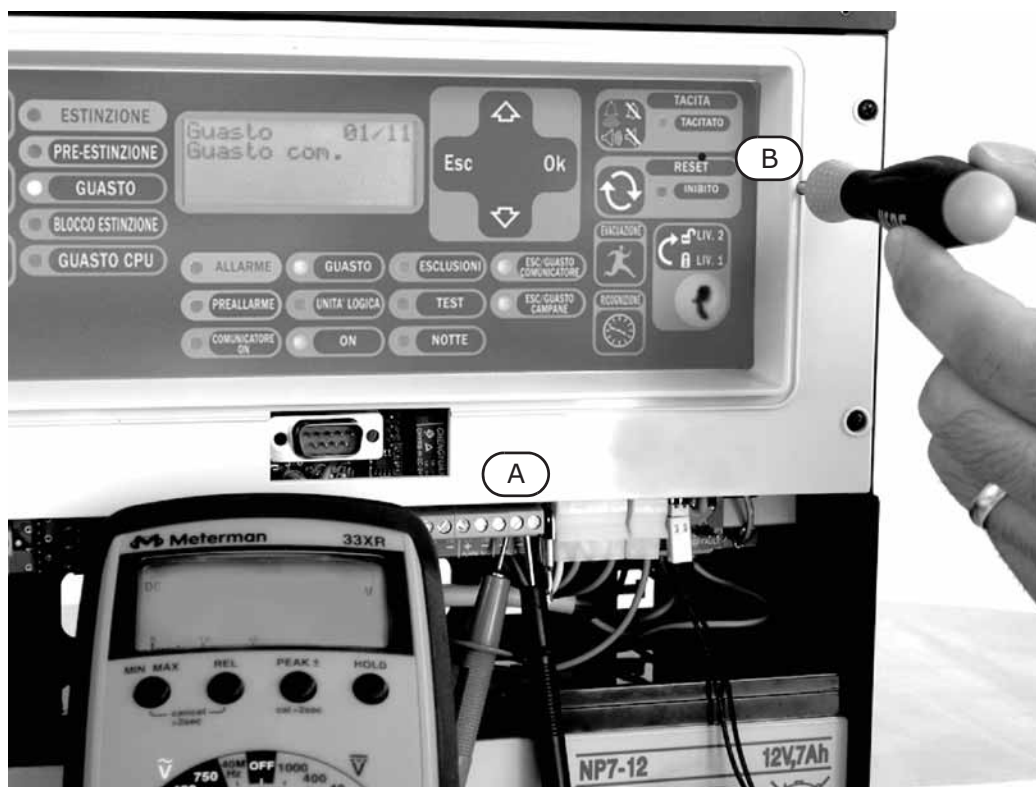

Figure 33 - Adjusting the voltage charge

Powering up and configuring the system

7.1 Testing wiring integrity

Before powering-up the system, check the wiring integrity and the isolation between the wires and earth.

1. Remove the jumper (paragraph 4.1 - [N]) in order to bypass earth fault check.
2. Using a tester, check that the resistance between each wire and earth is infinite.
3. Replace the jumper in order to unby pass earth fault check.
4. Disconnect the wires of each line.
5. Using a tester, ensure that the line resistance corresponds to the value as the EOL resistance.
6. Disconnect the wires of the supervised outputs from the respective terminals on the motherboard.
7. Using a tester, measure the cable resistance. Test both polarities. At least one must have the same resistance value as the EOL resistor.
8. Check that all cables are properly separated, bunched (by means of cable ties) and attached firmly to the cable hooks on the backbox.
9. Check the proper polarity of the primary power source connections (230 Vac).
10. Ensure that the cable is attached firmly to the cable hook by means of a plastic cable tie.
11. Ensure that the repeater panel address DIP microswitches have been set properly (paragraph 5.2.3 - [A]).
12. Ensure that the EOL resistance jumper of the last device connected to the BUS is in the EOL position.

7.2 Connecting the RS232 PC serial link

Connect the RS232 cable to the apparatus by means of an RS232 serial input (paragraph 4.1 - [O]).

Note: *The connection between the panel and the PC will be operative only when the PC programming jumper is inserted.*

The cable should be connected to the device as shown:

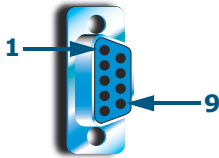
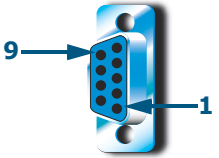
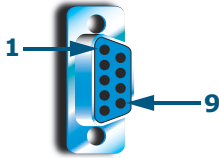
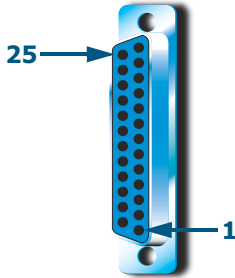
SmartLine end DB9F connector		PC end DB9F connector	
	2	3	
	3	2	
	4	4	
	5	5	
	6	6	
	7	7	
	8	8	
SmartLine end DB9F connector		PC end DB25F connector	
	2	2	
	3	3	
	4	20	
	5	7	
	6	6	
	7	4	
	8	5	

Note:

The RS232 link can be ordered separately. The order code is indicated in Appendix B - Order Codes. If your PC does not have a RS232 port but has a USB, use an RS232-USB adaptor.



7.3 Powering up the system

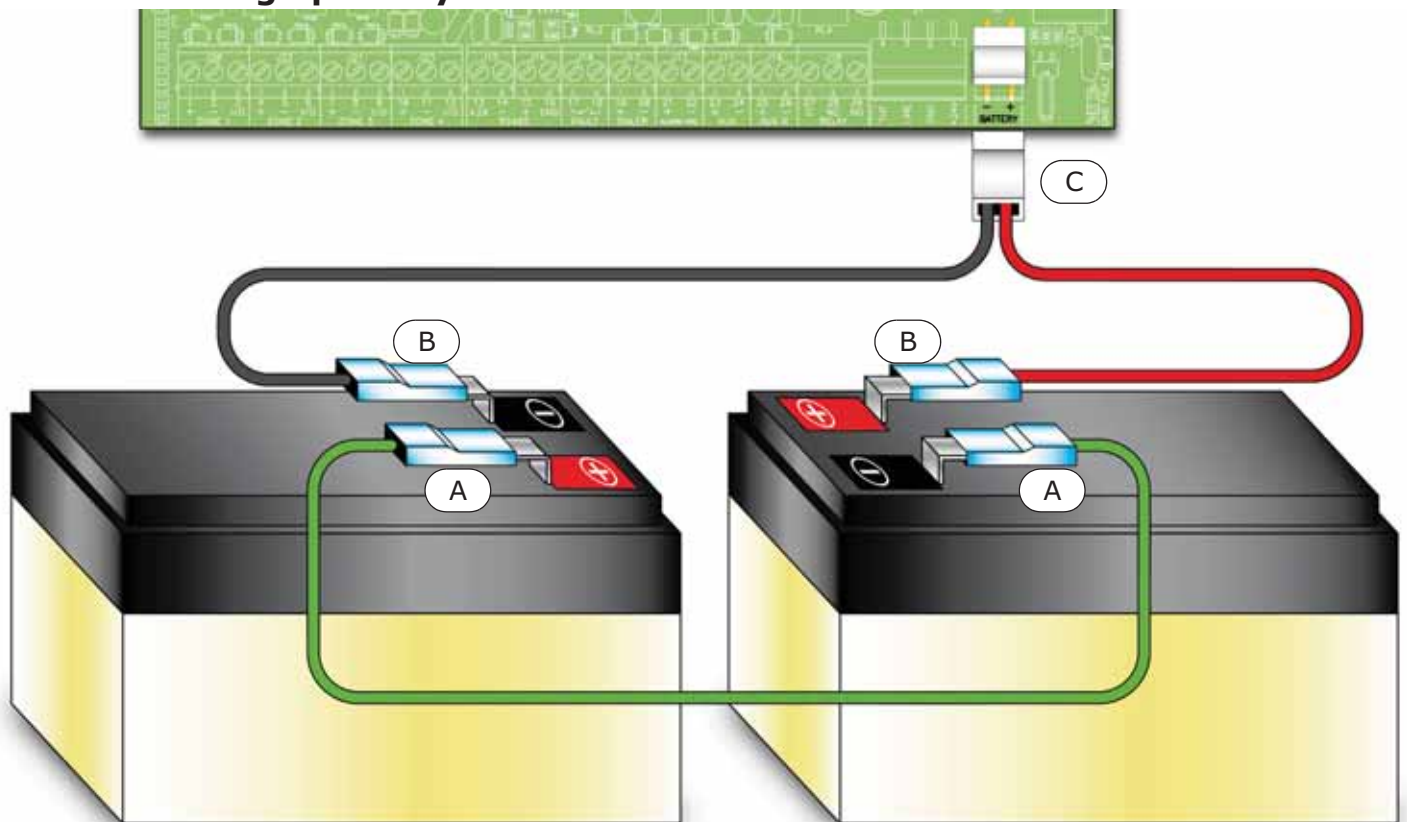

Figure 34 - Connecting the batteries

1. Connect the connection wire [A] to the batteries. Refer also to paragraph 6.15 - *Connecting the batteries*.
2. Connect the connection wire [B] to the batteries.

Attention: Be sure that cable polarity is correct.

3. Connect the connector [C] of the battery wire to the control panel (paragraph 4.1 - [K]).

Attention: Ensure that connector polarity is correct.

The panel will take several seconds to stabilize, startup will be indicated by an intermittent audible signal and the "Resetting".

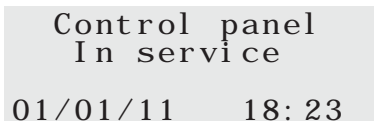

Control panel
In service
01/01/11 18:23

Figure 35 - Reset signaling

Full panel reset will be indicated by:

- The On status of the green LED (paragraph 5.1.2 - [S]) indicates that the panel is operating.
- The CPU LED (paragraph 5.1.2 - [P]) will blink to indicate that the board is initializing.
- If you do not carry out the successive step (connection to the mains power source) within 2 minutes, the FAULT LED (paragraph 5.1.2 - [C1]) will go On and the "Mains Fault" message will appear on the display.

4. Power up the panel from the mains.

In the event of restoral of a Mains fault; the FAULT LED will blink to indicate that the event has been saved to the memory.

5. If the fault persists, check all wiring sections thoroughly. See Chapter 16 - *Diagnostics and fault solutions*.

6. Once all faults have been cleared, turn the key in the keyswitch (access Level 2) and press the **RESET** button (paragraph 5.1.1 - [D]).

After Reset operations, all the LEDs should go OFF, with the exception of the green ON LED (paragraph 5.1.2 - [S]).

The display will show "Panel working" message.

7. Press any key to access the main menu. Using the cursor key ▼ select the second option on the "Test LEDs" menu. Press and hold the **Ok** key and check that all the LEDs go On.

Chapter 8

Introduction to Programming form the panel

The control panel and its zones and outputs can be programmed and configured via the control panel or by means of the SmartLeague software programme. For a brief description of the software application and the programming process, refer to *Chapter 14 - SmartLeague software* or, for a more complete description, refer to the SmartLeague user's guide.

Access to programming is allowed only after the programming jumper has been inserted:

```
Control panel
IN PROGRAMMING
Ver. 2.00
01/01/00 00:00
```

1. Remove the frontplate.
2. Insert the programming jumper (refer to paragraph 4.1 - [P]).
3. The display will show the relevant message.
4. The panel switches Off: no faults or alarms will be signaled.

```
Control panel
IN MAINTENANCE
Ver. 2.00
01/01/00 00:00
```

If this message appears, the programming phase has been blocked via PC. If this occurs, only maintenance functions can be accessed.

Note: To unblock the programming phase, start the SmartLeague application on the PC and type in the code previously used to block it. This feature protects the system from being accessed by persons other than qualified technicians authorized by the Installer company.

Menu options

```
→001<Zone Descr. >
002<Zone Descr. >
003<Zone Descr. >
004<Zone Descr. >↓
```

Press **Ok** to access the zone screen.

'↓' indicates that there is further information after the last line.

Press **Esc** to step back to the previous screen.

Editable alphanumeric field

```
Modify descr.
↑↓: move OK: mod.
<Zone 001>
```

Use keys ▲ and ▼ to move along the string.

Press and hold **Ok** to scroll the alphanumeric characters.

Press **Esc** to confirm the data entry, exit and step back to the previous screen.

Editable numeric field

```
→Delay mains fail
-- hour -- min.
Delay dialler
-- min -- sec
```

Press and hold **Ok** to scroll the values the two-digit counters (e.g.: 0 to 99 and "--", which means non-specified).

Use key ▲ or ▼ to move to the next programming field.

Press **Esc** to confirm the data entry, exit and step back to the previous screen.

Variable field

```
Alarm: YES
Pre-alarm: YES
GAS Alarm: YES
GAS Pre-Alarm: NO
```

Use key ▲ or ▼ to scroll the list.

Press **Ok** to toggle the parameter in the programming field (e.g.: YES to NO).

Press **Esc** to confirm the data entry, exit and step back to the previous screen.

Chapter 9

Programming from panel

This section describes how to program the control panel.

9.1 Configuring the control panel

From panel: <key>, **Programming, Configuration**

The first step is to configure the control panel. Press **Ok** after you select "Acquire int. bus", the display will show the current configuration of the control panel (i.e. the number of extinguish and expansion boards).

```
Current devices
Extin. module 0
Expansion      0
OK per execute
```

Press **Ok** to initiate the scanning phase. On completion of this phase, the control panel will enroll the properly connected extinguish board (one only) and expansion boards. Ensure that the configuration is correct, then press **Esc** to exit.

Select "Acquire ext.bus" and press **Ok**, the display will show the number of Repeaters in the current system configuration.

```
Current devices
Repeater      0
Power Station 0
OK per execute
```

Press **Ok** to initiate the RS485 BUS scanning phase. On completion of this phase, the control panel will enroll all the properly connected devices found on the RS485 BUS.

Once a component has been enrolled, it will be monitored by the control panel. If the device for any reason does not respond or is not functioning properly, the control panel will signal a fault.

9.2 Programming the zones

From panel: <key>, **Programming, Progr. Zone**, select zone number, **Ok**

This section describes the zone parameters of the detection line and the I/O line.

Attention: Consult the local laws in force for any restrictions regarding the definition of zones (dimensions and installation).

9.2.1 Zone parameters

ZONE	Pre-set zone number (from 2 to 20 or 36, depending on the control panel model).
<aaaaaaaaaaaa>	Zone Description (e.g.downstairs kitchen).
Pre-alarm	Length of pre-alarm signal for the zone. The zone will trigger an alarm when the set time expires..
Investigate	Length of investigation time, the countdown starts when the INVESTIGATE button is pressed during pre-alarm status. Pressing this button will stop the pre-alarm timer and start the "Investigate" timer.
Verify alarm time	If this option is enabled for the detection line (details follow), the control panel will not activate an alarm when it receives an alarm signal from one of the line detectors but will reset the detector that triggered the alarm and will start the pre-set verify alarm time. The control panel will consider the alarm valid only if the detector signals the condition again within the preset time.
Filter time	If the "Filtered" option is enabled for the zone detection line or I/O line, this represents the minimum duration of an line alarm or fault signal before the control panel will consider it as valid. This filter avoids accidental activation of fault or alarm signals caused by instant activation (for example, when an elevator trolley violates the area covered by a linear smoke detector).

- Detection line** Press **Ok** when the cursor is positioned on this line, to access the programming page relating to the detection line of the selected zone.
- I/O line** Press **Ok** when the cursor is positioned on this line, to access the programming page relating to the I/O line of the selected zone.

9.2.2 Detection line parameters

<aaaaaaaaaaaa> Zone description (e.g. downstairs kitchen). The field cannot be edited at this point. If you wish to change the string, you must step back to the previous menu.

Line type Using the **Ok** key, scroll the various activation types that can be assigned to the detection line:

FIRE ALARM The line will operate as a fire detection line. Activation of the line will generate a fire alarm. The line will remain active until the control panel resets.

Modify levels Position the cursor on this option then press **Ok** to access the detection line threshold-adjustment wizard (refer to Chapter 10 - *Detection line threshold-adjustment* for details).

Det.Missing If this option is enabled, the voltage on the line will be reversed periodically for several mS, in order to check if any detectors have been removed from their bases. This function mode can be applied only when bases with diodes have been suitably wired using an EOL diode/capacitor connected in parallel (refer to the wiring diagram).

Detect CP If this option is enabled, the line will discriminate between alarms generated by callpoints and detector. Alarms generated by callpoints will override the pre-alarm time and activate instant alarms. This option can be enabled only when the line is wired as indicated in the respective wiring diagram.

Short=Alarm If this option is enabled, short-circuits on the line will activate the line itself (depending on the type of line: Alarm, Supervision, etc.).

NightPrealarm If this option is enabled, the line will signal pre-alarm conditions even when the system is operating in Night Mode (the Pre-alarm feature must also be enabled).

Verify If this option is enabled, the control will remove the power from the line (and its detectors) when it receives an alarm signal from one of the line detectors. After reset (a few seconds), it will repower the line (and detectors) and will consider the alarm valid only if the detector signals the condition again within the preset "Verify alarm time".

Prealarm If this option is enabled, the control will signal pre-alarm for the pre-set time when the line triggers an alarm.

Filtered If this option is enabled, an alarm or fault condition on the line will be activated only when it persists for a period of time longer than the pre-set "Filter Time".

RESET ALARM The line will operate as a fire detection line. Activation of the line will generate a fire alarm. The line will remain active until the detectors connected to it remain in alarm status, once the detectors restore to standby, the signaling on the control panel will stop.

Modify levels As seen before.

Det.Missing As seen before.

Detect CP As seen before.

Short=Alarm As seen before.

NightPrealarm As seen before.

Verify As seen before.

Prealarm As seen before.

Filtered As seen before.

The line will operate as a resettable alarm line (it will remain active for the duration of the alarm condition). Activation of the line will generate a fire alarm and the display will indicate activation of the "Sprinkler" system. The line will also generate the "Sprinkler" signal that can be used for the activation of specific outputs which provide separate signals.

SPRINKLER

- Modify levels** As seen before.
- Short=Alarm** As seen before.
- NightPrealarm** As seen before.
- Prealarm** As seen before.
- Filtered** As seen before.

The line will signal a specific fault condition and will activate Fault and Supervision signals that can be used for the activation of specific outputs.

SUPERVISORY

- Modify levels** As seen before.
- Short=Alarm** As seen before.
- Filtered** As seen before.

The line will interface gas detectors with output relay (see the respective diagram). Pre-alarm activation will generate a pre-alarm gas signal, if the pre-alarm clears (restores to standby), the control panel will stop signaling. In the event of alarm activation, the control panel will signal a gas alarm.

GAS RELAY

- Modify levels** As seen before.
If you select "Yes", alarm signalling will cease when the value returns below the set threshold; otherwise alarm signalling will persist until the next reset operation occurs.
- Reset.Alarm**
- Filtered** If this option is enabled, an alarm or fault condition on the line will be activated only when it persists for a period of time longer than the pre-set "Filter Time".
- Passing** If this option is enabled, the line will be activated with no alarm signalling; useful for CO gas detection in parking areas.

The line will be used to command the extinguishment board functions. The type of command that is achieved by activating the line can be set on the two lines that follow. The available functions are: Disable extinguish; Disable manual extinguish; Disable automatic extinguish; Confirm extinguish; Manual extinguish; Stop extinguish. For further details regarding the previously mentioned functions, refer to the extinguishant board section.

EXTINGUISH

- Modify levels** As seen before.
- Short=Alarm** As seen before.
- Filtered** As seen before.

9.2.3 I/O detection line parameters

<aaaaaaaaaaaa> Zone description (e.g.downstairs kitchen). The field cannot be edited at this point. If you wish to change the string, you must step back to the previous menu.

Line type Using the **Ok** key, scroll the various programming options for the I/O line:

In this mode, the line will operate as an Open-Collector output that will activate in response to any of the selected signals ("Alarm", "Pre-alarm", "Gas alarm", "Gas pre-alarm", "Sprinkler", "Supervisory", "Class Change" and "Fault") relative to the control panel (if the "Panel" option is selected from the following list), or relative to the zones specified in the list (All zones set as "YES").

OUTPUT ZONE STATUS

- Silenceable** If "YES" is selected, it will be possible to switch Off the activated output by inserting the key and pressing the **SILENCE** button.
- Inverted** If selected, the output will always be closed to ground and will open when activated.

Endurance
-- min -- sec Activation time (0 to 10 minutes); if the endurance is not defined ("--") the output will not deactivate. Under all circumstances, if the condition clears the output will deactivate.

At least 1 / 2
/ All The output will activate if one or more signals activates on at least one/two/all of the selected zones.

OUTPUT DISABLE- MENTS

In this mode, the line will operate as an Open-Collector output that will activate when any of the control panel components is bypassed (if "Panel" option is selected), or when one or more zones (all the zones set as "YES") are bypassed.

Silenceable As seen before.

Inverted As seen before.

Endurance
-- min -- sec As seen before.

At least 1 / 2
/ All The output will activate if at least one/two/all of the selected zones are disabled.

OUTPUT EXTINGUISH

In this mode, the line will operate as an Open-Collector output that will activate in response to the selected extinguishant module signals: "Disable manual"; "Disable automatic"; "Pre-extinguish"; "Extinguish"; "Confirm extinguish"; "Pressure Switch".

Silenceable As seen before.

Inverted As seen before.

Endurance
-- min -- sec As seen before.

OUTPUT SIGNALS

In this mode, the line will operate as an Open-Collector output that will activate in response to the selected conditions: ("Reset", "Day", "Night").

Silenceable As seen before.

Inverted As seen before.

Endurance
-- min -- sec As seen before.

OUTPUT TIMERS

In this mode, the line will operate as an Open-Collector output that will activate in response to the activation of the specified timers (i.e. all timers set as "YES").

Silenceable As seen before.

Inverted As seen before.

Endurance
-- min -- sec As seen before.

OUTPUT EQUATIONS

In this mode, the line will operate as an Open-Collector output that will activate when at least one of the specified equations is satisfied (all the equations set as "YES").

Silenceable As seen before.

Inverted As seen before.

Endurance
-- min -- sec As seen before.

OUTPUT GAS OUTPUT

In this mode, the line will operate as an Open-Collector output that will activate when the average reading of the values relating to the 4-20 mA gas detector, connected to the I/O lines of the selected zones, exceeds the set level.

Silenceable As seen before.

Inverted As seen before.

This option is available for the first four zones on the motherboard only; if selected, the output will operate as a PWM (Pulse Width Modulation) output with a period of 0.5 s and a Duty Cycle of:

- 0%, if the average smoke reading is less or equal to the "Level 1" setting
- 100%, if the average smoke reading is more or equal to the "Level 2" setting
- proportional to the average reading, if it is between the two set levels

If the output is set as "Analog" and is equipped with an external filter, it can be used to control an inverter that activates a ventilator whose speeds will be proportionate to the average smoke reading.

Analog

INPUT FIRE ALARM

The line will operate as a fire detection line. Activation of the line will generate a fire alarm. The line will remain active until the control panel resets.

Prealarm If "YES" is selected, a pre-alarm signal will be sent when the line activates and will last for the duration set for the zone concerned.

NightPre-alarm If this option is enabled, the line will signal pre-alarm conditions even when the system is operating in Night Mode (the Pre-alarm feature must also be enabled).

Filtered If "YES" is selected, alarms or faults on the I/O line will be signaled only when the conditions persist for longer than the "Filter Time" of the zone concerned.

INPUT GAS 4-20mA

In this mode, the I/O line will operate as a gas detection line for gas detectors with 4-20mA output. If a detector exceeds the pre-alarm threshold, it will generate a gas pre-alarm signal. If the current output drops below the pre-alarm threshold, the signal will clear. If a detector exceeds the alarm threshold, it will generate a gas alarm signal.

Modify levels Position the cursor on this option then press **Ok** to access the detection line threshold-adjustment wizard (refer to Chapter 10 - *Detection line threshold-adjustment* for details).

Reset.Alarm If you select "Yes", alarm signalling will cease when the value returns below the set threshold; otherwise alarm signalling will persist until the next reset operation occurs.

Filtered As seen before.

Only progr. bar / Show LEL / Show PPM 2000FS / Show PPM 500FS

Section to select the detection units of measurement.

Passing If this option is enabled, the line will be activated with no alarm signalling; useful for CO gas detection in parking areas.

INPUT DISABLEMENTS

In this mode, the I/O line operates as a supervised input line that when activated bypasses the zones specified in the lines that follow (all zones with "YES").

Filtered As seen before.

INPUT CLASS CHANGE

During this operating mode, the I/O line will operate as a supervised output which when activated will not provide any data on the display but will activate the "Class Change" signal for the zones specified below (all zone set as "YES"). In this way it will be possible to activate all the outputs that are set up to activate the "Class Change" signal of the respective zones. This function is useful in school building installations, where the alarm bells can be activated manually in order to signal the end of a lesson.

Filtered As seen before.

NAC on CC If you select "Yes", each time the "Change Class" signal activates, the Alarm NAC output on the panel will also activate.

INPUT SPRINKLER

The line will operate as a resettable alarm line (it will remain active for the duration of the alarm condition). Activation of the line will generate a fire alarm and the display will indicate activation of the "Sprinkler" system. The line will also generate the "Sprinkler" signal that can be used for the activation of specific outputs which provide separate signals.

Pre-alarm As seen before.

NightPre-alarm As seen before.

Filtered As seen before.

In this mode, the I/O line will operate as a supervised output that when activated will perform the actions specified below:

INPUT COMMAND

- Filtered** As seen before.
- Reset** Replicates the **RESET** button on the control panel.
- Investigate** Replicates the **INVESTIGATE** button on the control panel.
- Silence** Replicates the **SILENCE** button on the control panel.
- Toggle day** Inverts the Day/Night operating from Day to Night.
- Force night** The control panel will operate in Night mode for the time the input is active.
Functions only when the pre-alarm time is running, in this case the pre-alarm time will be ignored and the control panel will generate an instant alarm. If the pre-alarm time is not running, it will have no effect.
- Evacuate**

The line will be used to command the extinguishment board functions. The type of command that is achieved by activating the line can be set on the two lines that follow. The available functions are: "Disable extinguish", "Disable manual", "Disable automatic", "Confirm extinguish", "Manual extinguish", "Lock extinguish". For further details regarding the previously mentioned functions, refer to the extinguishment board section.

INPUT EXTINGUISH

- NC input** If you select "Yes", the standby and alarm intervals will be reversed; for use with Normally Closed contacts.
- Filtered** As seen before.

9.2.4 Programming the outputs

From panel: <key>, **Programming, Progr. Output**, select an output, **Ok**

This option will allow you to set up the operating mode of each output (RELAY, Expansion board NAC outputs).

9.2.5 Outputs parameters

Relay, Expansion NAC..., Power Stat... Name of the output you are configuring.

Activation Type Using the **Ok** key, scroll the various activation types that can be assigned to the output:

OUTPUT ZONE STATUS

In this mode, the output will activate in response to any of the selected signals ("Alarm", "Pre-alarm", "Gas alarm", "Gas pre-alarm", "Sprinkler", "Supervisory", "Class Change" and "Fault") relative to the control panel (if the "Panel" option is selected from the following list), or relative to the zones specified in the list (All zones set as "YES").

Silenceable If "YES" is selected, it will be possible to switch Off the activated output by inserting the key and pressing the **SILENCE** button.

Inverted If selected, the output will always be closed to ground and will open when activated.

Endurance -- min -- sec Activation time (0 to 10 minutes); if the endurance is not defined ("--") the output will not deactivate. Under all circumstances, if the condition clears the output will deactivate.

At least 1 / 2 / All The output will activate if one or more signals activates on at least one/two/all of the selected zones.

OUTPUT DISABLE-MENTS In this mode, the output will activate when any of the control panel components is bypassed (if "Panel" option is selected), or when one or more zones (all the zones set as "YES") are bypassed.

Silenceable As seen before.

Inverted As seen before.

Endurance -- min -- sec As seen before.

	The output will activate if at least one/two/all of the selected zones are disabled.
At least 1 / 2 / All	
OUTPUT EXTINGUISH	In this mode, the output will activate in response to the selected extinguishant module signals: "Disable manual"; "Disable automatic"; "Pre-extinguish"; "Extinguish"; "Confirm extinguish"; "Pressure Switch".
	Silenceable As seen before.
	Inverted As seen before.
	Endurance As seen before. -- min -- sec
OUTPUT SIGNALS	In this mode, the output will activate in response to the selected conditions ("Reset", "Day", "Night").
	Silenceable As seen before.
	Inverted As seen before.
	Endurance As seen before. -- min -- sec
OUTPUT TIMERS	In this mode, the output will activate in response to the activation of the specified timers (i.e. all timers set as "YES").
	Silenceable As seen before.
	Inverted As seen before.
	Endurance As seen before. -- min -- sec
OUTPUT EQUATIONS	In this mode, the output will activate when at least one of the specified equations is satisfied (all the equations set as "YES").
	Silenceable As seen before.
	Inverted As seen before.
	Endurance As seen before. -- min -- sec

9.3 Setting the Timers

From panel: **<key>, Programming, Progr. Timer**, select a timer, **Ok**

This option will allow you define the timer intervals (e.g.: from 13.00 to 14.00), dates (e.g.: 25-12-2006) or special days (e.g.: Sundays and days of closure). The timer can be included in an equation and can contribute to the activation of an output. Timer activation may trigger associated actions (e.g. bypass a zone, toggle to Night Mode).

Navigate through the programming field and set the new values.

9.3.1 Timer parameters

Timer n	Timer number (maximum 8), preset.
Enabled	If you select "Yes", the selected timer will be enabled.
Start/End time 1	Hour and minutes of the Start and End of the interval 1.
Start/End time 2	Hour and minutes of the Start and End of the interval 2.
Day, Month, Year	Operational date of the timer. To indicate any day, month or year, leave "--" (for example, every 3rd of the: day=3, month = "--", year = "--").
Sunday, etc.	Day of the week for weekly arrangements. Valid only when the "Day", "Month", "Year" are set as "--".
Holidays	If you select "Yes" the timer will operate during the programmed holiday periods (refer to <i>paragraph 9.3 - Setting the Timers</i>).

NO Holiday	If you select "Yes", the timer will not activate during holiday periods; this option has priority over the previous two options.
Force night	Activation of the timer will switch the panel to Night mode. The panel cannot be switched back to Day mode until the set timer interval expires. Once the set timer interval expires, the panel can be switched back to day mode either by another timer or manually from the panel (refer to paragraph 15.3 - <i>Day/Night Mode</i>).
Set day	Activation of the timer will switch the panel to Day mode. The panel can be switched back to Night mode either by another timer or manually from the panel.
Set night	Activation of the timer will switch the panel to Night mode. The panel can be switched back to Day mode either by another timer or manually from the panel.
Disable zone	On activation the timer will bypass the specified zone.
Enable zone	On deactivation, the timer will unby pass the selected zones.
Disable verif.	When the timer is activated, the alarm verify is disabled on the selected zone.
Zone	List of zones to be bypassed on timer activation (zones set as "YES" will be bypassed).

9.4 Setting holidays

From panel: <key>, **Programming, Progr. Holidays**, select a holiday, **Ok**

This option will allow you to set specific periods which determine exceptions with regard timer programming, for example, holidays, bank holidays, etc. Navigate through the programming field and set the new values.

9.4.1 Holydays parameters

Holiday nn	Number of holidays (maximum 15), already preset.
day, month, year	Date of the holiday or start date of the holiday period. To indicate any day, month or year, leave "--" (for example, every 3rd of the: day=3, month = "--", year = "--").
Sunday, etc.	Day of the week for weekly arrangements. Valid only when "Endurance"=1 and "Day", "Month", "Year" = "--".
Endurance	Length of time (expressed in days) of the holiday period (0 at default). If you set 0, the system will not take the holiday into account.

9.5 Setting the control panel options

From the panel: <key>, **Programming, Options**

Navigate through the programming field and set the new values.

9.5.1 Options

Delay mains failure	A delay (0 to 30 minutes) which must run before the mains failure event is signalled. This delay avoids unnecessary signaling of brief 'Mains failure' events.
Delay dialler	The period (0 to 10 minutes) which the dialler allows before signaling a zone alarm. If an alarm is activated from a manual callpoint or by means of the EVACUATE button, the output will activate immediately.
Night silence time	The duration (0 to 10 minutes) of Silence status when the system is operating in Night mode (starting from the moment the SILENCE key is pressed).
Time lock reset	The period (0 to 30 minutes), after extinction activation, when reset operations are not allowed. If a confirm extinction signal is sent to the extinction module during this period, reset operations will be re-enabled.
Time reset	Line reset time (2 to 10 seconds): during this period the power supply to the line is removed, in order to restore the detectors to standby after an alarm.
Time ignore	During this period (1 to 5 seconds), which starts after reset, the lines will not be taken into account thus allowing the line devices to stabilize and restore to standby.

24VR cond. If this option is set as "NO", the AUX-R output will always be active except during Reset time when it will be off.
If this option is set as "YES", the AUX-R output will always be active except when one or more of the zones listed under the option is set as "YES" go into alarm status.

Events on disabled If enabled, this option allows the control panel to register in the log any change of status of the disabled zones.

Slave on485 When activated, the control panel is seen as a power station connected to the SmartLoop RS485 bus in slave mode.
After this option is activated it is possible to change the address of the control panel:
From panel: **<key>, Programming, Configuration, Acquire int.bus, Ok**

Real time

Control panel If this option is enabled (option ="YES"), the display provides a value bar showing the real-time values of the I/O lines of the specified zones during standby status. This function can be used when the I/O lines are configured as 4-20mA gas lines, and allows users to view the level of gas detected by each line.

Repeater n If this option is enabled (option ="YES"), the display provides a value bar showing the real-time values of the I/O lines of the specified zones during standby status. This function can be used when the I/O lines are configured as 4-20mA gas lines, and allows users to view the level of gas detected by each line.

9.6 Setting up equations

From panel: **NOT available**

This section (available form SmartLeague software only) will allow you to define 7 equations that the control panel can use in order to activate the outputs.

Each equation can be defined using operands (zone signals, timers and constants) and operators (AND, OR, NOT, XOR, +, >, >=, <, <=, !=, =).

Detection line threshold-adjustment

By means of the guided threshold settings procedure, it is possible to configure the intervention thresholds of the detection lines and I/O lines configured as "INPUT GAS 4-20mA".

From panel: **<key>, Programming, Progr. Zone**, select a zone, **Detection line** or **I/O line, Modify levels, Use wizard, Ok**

The control panel will ask you to perform a series of operations on the line you are working on (open the line then press **Ok**, Balance the line then press **Ok**, etc.). During each phase, the display will show the terminal value reading (expressed in Volts), and a graphic bar that indicates the reading.

Once the requested operations have been completed, the display will show the value in volts and the point on the graphic bar where the various thresholds are set. Each threshold can be adjusted by means of the UP and DOWN scroll keys. After setting the required value, press **OK** to confirm the entry.

This threshold-setting procedure will allow you to define the current limit (for each line) that discriminates standby status from an alarm, etc.

In this way, the control panel can be set up to work with all types of conventional detectors and existent detection lines with unknown resistance and balancing values. etc.

From panel: **<key>, Programming, Progr. Zone**, select a zone, **Detection line** or **I/O line, Modify levels, Import from, Ok**

The control panel will allow you to import the thresholds of a previously configured zone.

Attention: **If you change the line type of a zone, the thresholds will be restored automatically to default values.**

Programming the extinguishant module

The extinguishant module manages a gas extinguishant system activated by automatic or manual commands:

- automatic commands triggered by the fire-control panel when the programmed zones go into alarm status.
- manual commands from devices connected to the extinguishant module inputs or set up as fire-detection input point.

Therefore, the board makes use of its own terminals and those of the control panel zones, in order to obtain the activation conditions and command the outputs:

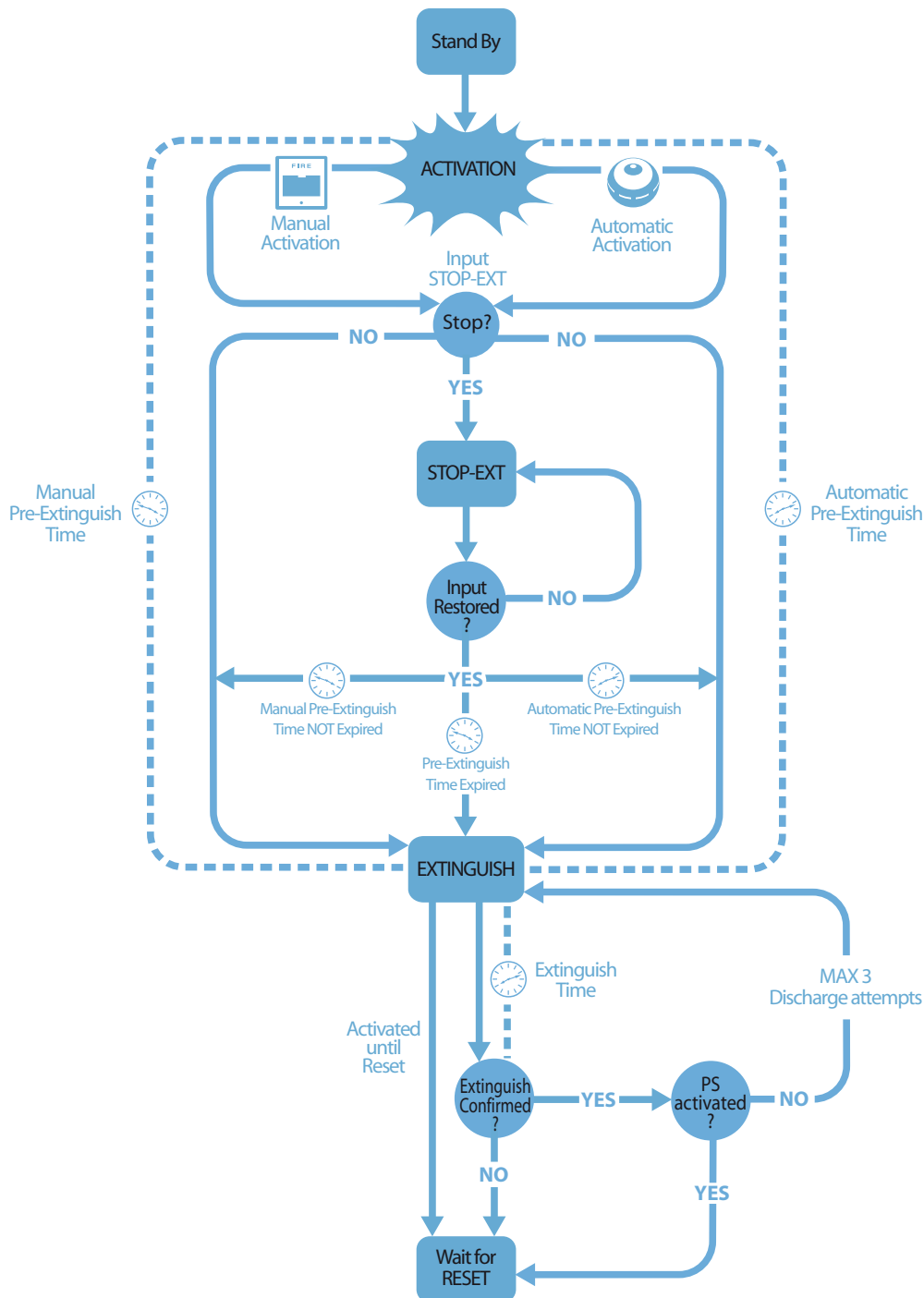

Figure 36 - Extinguishant module: operating principles

To ensure proper programming of the gas extinguishant system you must:

1. Configure the extinguishant module
2. Program the operating principles
3. Configure the Detection lines and I/O utilized by the extinguishant module

11.1 Configuring the extinguishant module

From panel: <key>, **Programming, Configuration, Acquire int.bus, Ok, Ok**

This function allows the control panel to detect the presence of the expansion boards and the extinguishant module.

11.2 Programming the module

From panel: <key>, **Programming, Extinguish, Ok**

Program the parameters that define the operating principles of the extinguishant system.

11.2.1 Module parameters

Zone mask	Zones that activate extinguish commands when they go into alarm status.
Mode:	<p>At least 1 / 2 / All The extinguishant gas release will activate if at least one/two/all of the selected zones go into alarm status.</p>
Confirm extinguish	<p>Extinguishant module feature that provides confirmation of extinguishant gas release. Press the Ok button corresponding to the option below.</p> <p>Do not confirm If an "Extinguish" event occurs, the extinguishment module will activate the VALVE output (for the pre-set time) and the RELEASED output without awaiting confirmation of extinguishant gas release.</p> <p>Wait for press. The RELEASED output will be activated when the "Extinguish time" expires, that is, if the "pressure switch" signal has been activated (from the pressure switch input or from a point set up as a "pressure switch" input). The "pressure switch" signal will be considered valid only when the signal persists after expiry of the extinguish time. Example: you can connect a pressure gauge to the PRESS. input, or to an input with the "pressure switch" attribute, that will signal when the cylinders empty (in order to confirm the successful saturation of the protected space).</p> <p>Wait for flow The RELEASED output will be activated when the Extinguish time expires, that is, if the "from flow detector" signal has been activated during this phase (from the pressure switch input or from a point set up as a "flow detector" input). EXAMPLE: You can connect a gas-flow signaling device to the PRESS input or a point set up as a "flow detector" input (the device will signal when gas is being released).</p>
Pressure switch	<p>Defines the significance of the signal coming from the PRESS input. Press the Ok button corresponding to the option below.</p> <p>Supervisory Activation of the input signals a drop in gas extinguishant pressure.</p> <p>From pressure Activation of the input indicates that the gas cylinders are empty, therefore, the protected space is saturated and activates the "confirm extinction from pressure switch" signal.</p> <p>From flow detector Activation of the input indicates that gas has been released and activates the "confirm extinction from flow detector" signal. If this option is selected, and the pressure switch activates during control panel standby status, it will trigger a control panel alarm.</p>
Time pre-extinction	Duration of the automatic pre-extinction, activated by a zone in alarm status.
Time extinguish	Length of time the electrovalve remains active, starting from the end of the pre-extinguish phase. If the value is not specified, fire extinguishment will be continue until the control panel RESET button is pressed.

Time pre-extinction manual	The duration of the manual pre-extinction phase, activated by a MAN-EXT input or Detection line set up as a manual extinction input.
Time confirm extinction	Delay between activation of the electrovalve output and the pressure switch activation analysis (if programmed as "Confirm extinguish"). Example: in this way, the device connected to the pressure switch input can detect the pressure drop inside the cylinders and intervene.
Pause between discharges	Length of the pause between one gas discharge and another in the event of non-confirmation of gas discharge (extinguishant module allows three discharge events).

11.3 Programming extinguish inputs/outputs

From panel: **<key>, Programming, Progr. Zone**, select a zone, **Detection line** or **I/O line, Ok**

Each Detection line or I/O line can be set up to generate functional signals to the extinguishant board, or to be activated by (in the case of an I/O line configured as an output) signals from the extinguishant board.

For further details regarding the extinguishment functions that can be associated with zones, refer to the zone configuration section.

Configuring the devices connected to the RS485 BUS

From panel: **<key>, Programming, Configuration, Acquire ext.bus, Ok, Ok**

The SmartLetUSee/LCD-Lite repeaters are clone panels. They are equipped with displays and LEDs and replicate all the information provided by the control panel. The panel supports up to 4 repeaters which, under normal circumstances, should be located at entrances/exits, in such way as to allow building occupants or fire officers to view alarm details without going too far inside the building.

The SmartLevel power-supply stations provide load current to remote apparatus located within the area covered by the system. The control panel supports two power-supply stations, for a maximum of six devices connected to the RS485 BUS.

After installing and addressing each device, you must include them in the system configuration.

```

Current devices
Repeater          x
Power Station     Y
OK per execute

```

This will allow the panel to determine which devices are connected to the BUS and indicate those found.

Note: *The panel uses the screen above to indicate the current configuration of the devices. If you press **Ok** (working from this screen), the panel will search the communication BUS and include any newly found devices in the configuration.*

Closing the programming session

Once you have completed the programming, remove the panel/PC programming jumper. The panel will be ready to go into service, and the display will be as follows.

```
Control panel
In service
17/09/11    5:40
```

Double check the functionality of all the input/output devices.

13.1 Restoring factory settings

From panel: **<key>, Programming, Factory data, Ok**

If you select this option, you will access the 'Confirm' screen. If you press **Ok** (working from this screen) all the programming data (panel and extinguishant module) will reset to default values (factory settings).

SmartLeague software

14.1 Overview

The SmartLine system can be programmed from the panel or from a PC. You can access all the programming process via the SmartLeague programming and management software for INIM Electronics security products.

The SmartLeague software programme allows you to access all the system parameters which can be accessed via the control panel. In addition, it provides a clear, complete view of the status of the system and its parts and thus a more precise programming process. The programming process is further enhanced by a greater number of parameters for each point and the use of combinatory logic in the zone "equations".

For further details regarding the SmartLeague software programme, refer to the respective user manual.

14.2 The Solutions

Each *Solution* comprises an installation structure and the respective group of programming parameters. You can save the system solution to the SmartLeague database and use it for maintenance purposes or as a "model" for other systems.

Each solution is dedicated to a device type and has its own programming interface. In this way, it is possible to compare different solutions, or keep two solutions open (one real and the other for test purposes), in order to verify step by step the effects of the programming process.

A solution can be created and changed without computer to device link up. For example, you can prepare a system layout and/or set parameters without leaving your office. The data can be downloaded to the system when you are ready.

14.3 Enable programming via PC

All functions can be accessed via PC without the need of connecting to the control panel; this connection will be necessary only during data upload (transfer of data from the PC to control panel) and download (transfer of data from the control panel to PC).

The extinguishant module can be programmed only via the SmartLeague software, whereas, the configuration and programming of the points can be done from the panel. If the programming jumper is not inserted, access to the programming via PC will be denied.



1. Remove the frontplate.
2. Insert the jumper (paragraph 4.1 - [Q]), the respective message will appear. The panel keys will be disabled.
3. Using the cable (refer to paragraph 7.2 - *Connecting the RS232 PC serial link*), connect the PC to the serial port (refer to paragraph 4.1 - [O]).

Chapter 15

Maintenance

The following operations must be carried out regularly.

1. Using a damp lint-free cloth, remove any dust that may have gathered on the control panel (do not use any kind of cleaning product or solvent!).
2. From panel: press **<key>, Test LED, Ok** to test the LEDs.
3. Check the battery efficiency and change them if necessary.
4. Check the integrity of all wires and connections.
5. Ensure that there are no insects inside the control panel.
6. Carry out maintenance on the detectors (clean the detection chamber).

Note: *Points 1 and 2 can be carried out by authorized persons, whereas all other points must be carried out by qualified technicians.*

15.1 Set Time and date

From panel with the jumper inserted: **<key>, Maintenance, Date & Time**

Navigate through the programming field and set the new values. The system will select the day of the week automatically.

15.2 Viewing events

The system displays information regarding real-time events of major importance and disregards those of minor importance (e.g.: if the system is dealing with three fault events when a pre-alarm event occurs, the fault events will be disregarded and cleared from the display and the pre-alarm will take priority). All events are saved to the log and can be viewed.

15.2.1 Signaling on the display

If several events of the same type occur, only the first will be shown on the display. If several alarms occur, the first alarm will remain on the first line of the display and the most recent alarm will be shown on the line below.

To view the events on the display, press button ▲ or ▼.

15.2.2 Viewing the events log

Press **<key>, View log, Ok**: all the recorded events (maximum 100) can be viewed in chronological order.

15.3 Day/Night Mode

15.3.1 Day

There are people in the building, therefore, those in charge of the safety of the building and its occupants should be duly informed before the evacuation command is given.

Silence	Silences (turns Off) the panel beeper and silenceable outputs. The Silence command will be undone automatically, if a new alarm event occurs (e.g.: another detector signals alarm conditions).
Pre-alarm	Some points can be programmed to signal pre-alarm status. If no-one intervenes during the pre-alarm phase, the system will generate an alarm when the programmed pre-alarm time expires. Refer to paragraph 9.2.2 - <i>Detection line parameters</i> to enable/disable the pre-alarm time of points.

15.3.2 Night

There are no people in the building, therefore, there is only one person in charge of building safety (e.g.: night watchman, guard).

- Silence** The Silence command holds off signaling. The Silence phase will run for the pre-set time. If no-one intervenes during this phase, the system will undo the silence command and the alarm will continue. To change the night-mode silence time, refer to paragraph 9.5 - *Setting the control panel options*.
- Pre-alarm** The pre-alarm signal can be disabled on certain points. Alarm events will generate instant alarms. Refer to paragraph 9.2.2 - *Detection line parameters* to enable/disable the pre-alarm time on points during Night mode.

15.3.3 Changing Day/Night mode manually

From panel with access level 2:<key>, **Settings**

15.3.4 Changing Day/Night mode automatically

Setting up a timer (refer to paragraph 9.3 - *Setting the Timers*) to toggle the panel status.

15.4 Bypassing a zone

From panel with access level 2:<key>, **Disablement, Zones**, select a zone, **Ok**

Under certain circumstances (e.g. maintenance or fault), it may be necessary to bypass a zone. Bypassed zones or points cannot generate fault or alarm signals and cannot be activated.

15.5 Bypass the DIALER or ALARM NAC output

From panel with access level 2:<key>, **Disablement, Outputs, Ok**

Under certain circumstances (e.g. maintenance or fault), it may be necessary to bypass the dialer outputs (paragraph 4.1 - [E]) or ALARM NAC (paragraph 4.1 - [F]). The bypassed object cannot be activated.

Bypass may be necessary in the event of fault signaling triggered by the Dialer or Supervised output (refer to Chapter 16 - *Diagnostics and fault solutions*).

15.6 Testing the zones

From panel with the jumper inserted:<key>, **Maintenance, Test zone**, select a zone, **Ok**

Maintenance work often entails zone tests. Activation of an alarm when a line is in Test status will activate the ALARM NAC output for approximately 3 seconds. The control panel will reset the line automatically when the brief output signal ends. This feature allows the technician to test the system without the assistance of another person.

Note: *The LED of detectors in test status will go on for several seconds, and the ALARM NAC will activate for 3 seconds to confirm reception of the alarm signal. The detector will reset automatically.*

```

Zone          04      ↑
<Zone  04>
In test      ↓
    
```

1. Press **Ok** to put the zone in test/operating status.
2. Press **▲** or **▼** to go to the adjacent zone.

15.7 Force the status of I/O lines configured as outputs

From panel with the jumper inserted:<key>, **Maintenance, Test outputs**, select a zone, **Ok**

In the event of maintenance or first power up, it may be necessary to activate manually the output of an I/O line configured as an output.

```
Zone      04  ↑
<Zone  04>
Off      ↓
```

1. Press **Ok** to activate/deactivate the output.
2. Press **▲** or **▼** to go to the adjacent output.

15.8 Set the date for the next maintenance session

From panel with the jumper inserted: **<key>, Maintenance, Maintenance date, Ok**

```
Maint.  Fault
01/01/01 01:01
Monday
```

If you have set the date of the next maintenance session, the system will signal a fault event on the specified date. Only a new date, selected via this menu, will clear this fault signal.

15.9 Reading the power supply tension

From panel with the jumper inserted: **<key>, Maintenance, Power level, Ok**

```
Power Level 24.4
```

The display shows the output voltage of the power supply module housed in the control panel.

This function is useful during the calibration of the charging voltage described in paragraph 6.16 - *Thermal Probe*.

Diagnostics and fault solutions

Danger: Only authorized operators (Level 2 or 3) may search for, and correct faults.

16.1 Fault "Open"

The panel is unable to find the EOL resistor on the supervised input/output terminals. The following line will specify the terminals concerned (NAC, detection line, I/O line, etc.).

Check the EOL resistor connection on the last device. Using a tester check that the resistor has not burnt out.

16.2 Fault "Shorted"

A short-circuit has been detected on the input/output terminals. The next line indicates the specific terminals (NAC, on a module connected to the detection line, etc.). Check the device connections and cable sections.

16.3 Repeater faults

If the number of repeaters recognized by the control panel is less than expected (refer also to Chapter 12 - *Configuring the devices connected to the RS485 BUS*):

1. Check that the address of each repeater has been set properly (by means of the DIP switches (paragraph 5.2.3 - [A]).
2. Check that the cabling is intact.
3. Check the connection polarity.
4. Check that the EOL jumper is in the EOL position only on the last repeater connected the BUS.
5. Using a tester, measure the voltage across the +24 V and GND terminals of the RS485 BUS.
If the voltage is less than 20 V, it means that the resettable protection fuse is open and the current draw of the devices connected to the BUS is excessive. Disconnect the BUS devices and reconnect them one by one until you find the problem.

16.4 Battery Fault

16.4.1 Battery Disconnected

The battery is not connected or has failed the batter efficiency test.

1. Allow the batteries to charge for several hours.
2. If the fault signal persists, disconnect the batteries from the panel and test them separately.
3. If only one of the batteries has a voltage below 12.5 - 13 V:
 - Replace the faulty battery only.
 - Allow the batteries to charge for several hours.
 - Check that the fault has cleared.
4. If both batteries have a voltage of 12.5 - 13 V, it means they are both inefficient (even though the voltage without load is correct).
 - Replace both batteries.
 - Allow them to charge for several hours.
 - Check that the fault has cleared.
 - With the batteries disconnected, check the voltage on the battery connector, ensure that it is 27.6 V, without a thermal probe, or follow the procedure described in paragraph 6.16.1 - *Connecting a thermal probe*.

16.4.2 Low Battery

The batteries are running low.

This signal should be present only during primary power source failure (Mains 230 Vac). Mains power must be restored in order to charge the batteries.

16.5 Other faults

The panel shows the message:	Meaning
Dialer Fault	Trouble on the dialer communication line (dialer output).
24V output	Short-circuit on the AUX terminals protected by the resettable fuse.
Mains fail	Primary power failure (230 Vac).
Ground fault	Voltage dispersion detected
Maintenance	The pre-set date for Maintenance has expired.

Iris devices



All devices in INIM ELECTRONIC's Iris series of conventional detection devices are LPCB certified and carry the CPD mark.

The technology incorporated in Iris series detectors allows you to configure individual detectors to suit their specific environments and, when used in conjunction with the EITK-DRV, to connect directly to the detector line for a complete diagnosis of each detector and thus test its operating capacity, verify its real-time values, view the contamination level in the optical smoke chamber and change its sensitivity and operating mode. Each detector has a non-volatile memory which allows you to view the smoke and temperature levels measured in the period prior to the last alarm detected.

The Iris series of INIM Electronics provides three conventional detector models:

- Optical chamber with sealed upper-part and 500 micron hole-diameter mesh insect screen
- Bicolour LED: red for alarm, green blinking for standby or for trouble
- Drift compensation for sensor drift caused by dust in the chamber
- Sensitivity selection for smoke and heat thresholds
- Operating mode selection (for ID300 version): only smoke, only heat
- AND mode, OR mode, PLUS mode
- Complete diagnostics - provides contamination level and real-time values
- Memory of the smoke and temperature levels measured in the five-minute period prior to the last alarm detected
- Bypass plate on base guarantees continuity in the event of removal of the detector from the line

For further details regarding the precise features and technical specification of each device, refer to the respective instructions booklet.

Type	Model	Description
Detectors	ID100	Optic smoke detector
	ID200	Heat detector
	ID300	Smoke and heat detector
Bases	EB0010	Mounting base
	EB0020	Relay base
	ESB010	Sounder base (to be installed under EB0010 mounting base with a dedicated wiring)
	ESB020	Sounder base and beacon (to be installed under EB0010 mounting base with a dedicated wiring)
Manual Callpoints	IC0010	Manual callpoint
	IC0010E	Manual callpoint for outdoor installation (IP67)
Alarm repeater	FI100	Remote addressable alarm repeater
Driver	EITK1000	Kit for the configuration, maintenance and diagnostics of systems using IRIS and ENEA series devices
	EITK-DRV	Driver for zones with IRIS series devices or loops with ENEA series devices
	EITK-BASE	Base for IRIS and ENEA series detectors
	EITK-PWSP	Power supply for the EITK-DRV driver

The distinct serial number of each detector is shown on the device information label.

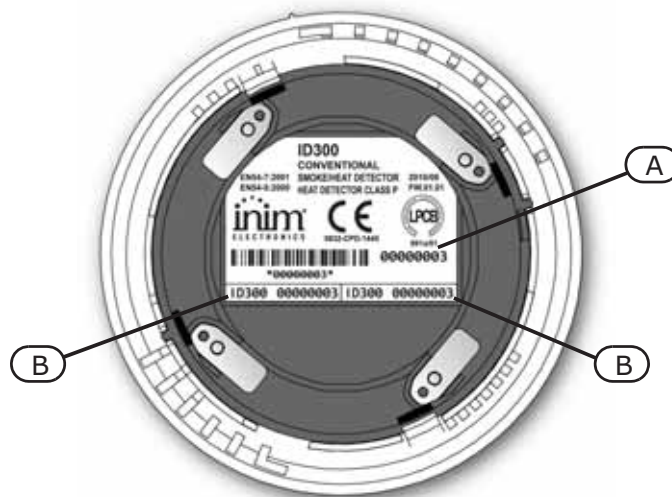

Figure 37 - The reverse side of Iris detectors

The serial number is shown on the information label [A] and on two smaller removable labels [B]. When installing the devices, it is strongly advised to remove the small labels and place one on the system layout and the other on the mounting base. This will facilitate device tracing and re-location operations.

Order Codes

Quote the following order codes when ordering INIM Electronics s.r.l. products:

Code	Description
DCMIINE0SLINE	Installation Manual
DCMUINE0SLINE	User's manual
Link232F9F9	RS232 link
LINKUSB232CONV	RS232-USB adapter cable
ProbeTH	Thermal probe for battery charge optimization
REL1INT	1 relay board
SmartLAN/485	Ethernet interface for Internet connection with TCP-IP protocol
SmartLeague	Programming software, runs under Windows
SmartLetLoose/ONE	Extinguishant module
SmartLetUSee/LCD-Lite	Repeater
SmartLine/8Z	8 conventional zones expansion board
SmartLine020-2	Conventional fire control panel with 2 zones (NON expandable)
SmartLine020-4	Conventional fire control panel with 4 zones expandable to 20 zones
SmartLine036-4	Conventional fire control panel with 4 zones expandable to 36 zones
SmartLook	Programming software for INIM systems, runs under Windows™
SPS24040	SmartLevel power supply station 1.4A 27.6V
SPS24140	SmartLevel power supply station 4A 27.6V

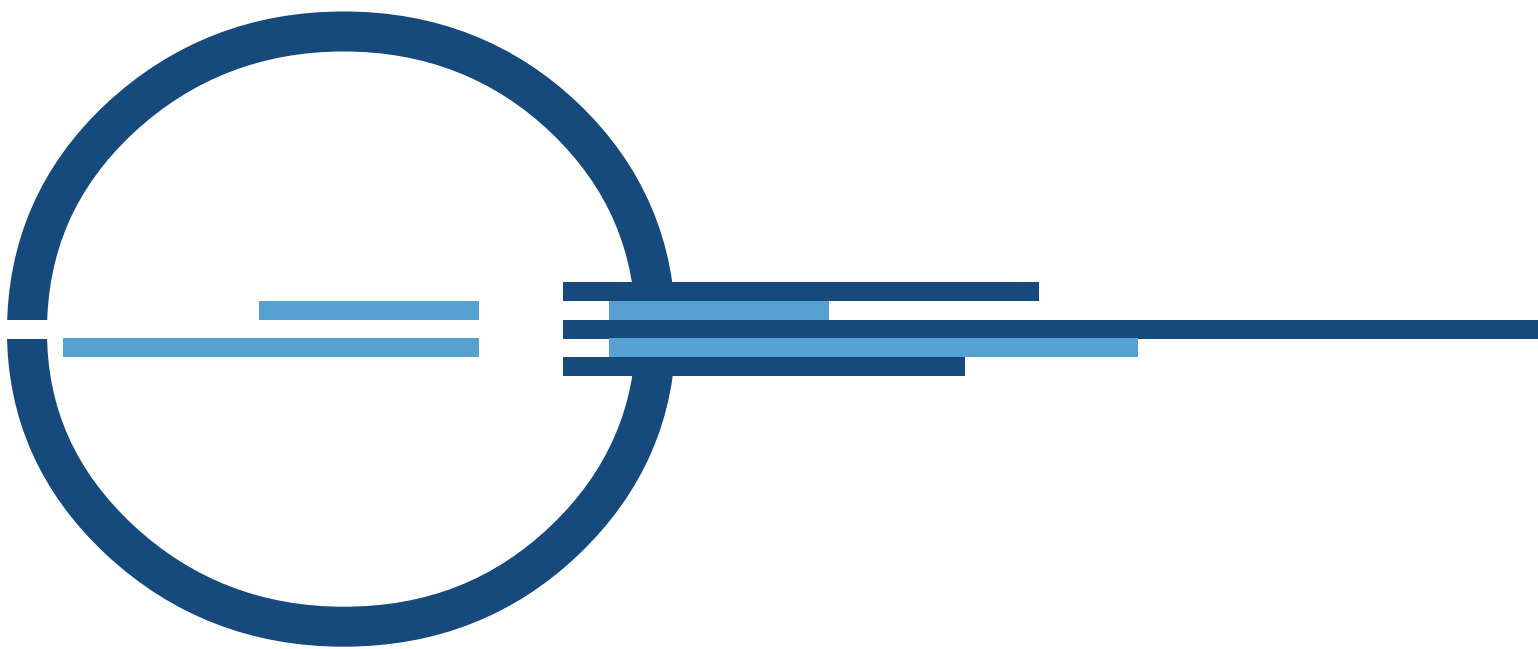

ISO 9001:2008 Registered Company

via Fosso Antico Loc. Centobuchi
63076 Monteprandone (AP) ITALY
Tel. +39 0735 705007 _ Fax +39 0735 704912

info@inim.biz _ www.inim.biz



ISO 9001
FM 530352

DCMIINE0SLINE-R300-20110518