

EN 54-2
EN 54-4
EN 54-21
EN 12094-1



CE
0832
0832-CPR-F1342

PREVIDIA | MAX



FIRE DETECTION AND EXTINGUISHANT SYSTEM



GameOver

INSTALLATION MANUAL

Warranty

INIM Electronics s.r.l. (Seller, Our, Us) warrants the original purchaser that this product shall be free from defects in materials and workmanship under normal use for a period of 24 months. As INIM Electronics s.r.l. does not install this product directly, and due to the possibility that it may be used with other equipment not approved by Us; INIM Electronics s.r.l. does not warrant against loss of quality, degradation of performance of this product or actual damage that results from the use of products, parts or other replaceable items (such as consumables) that are neither made nor recommended by INIM Electronics. Seller obligation and liability under this warranty is expressly limited to repairing or replacing, at Seller's option, any product not meeting the specifications. In no event shall INIM Electronics s.r.l. be liable to the purchaser or any other person for any loss or damage whether direct or indirect or consequential or incidental, including without limitation, any damages for lost profits, stolen goods, or claims by any other party caused by defective products or otherwise arising from the incorrect or otherwise improper installation or use of this product.

This warranty applies only to defects in parts and workmanship relating to normal use. It does not cover:

- damage arising from improper maintenance or negligence
- damage caused by fire, flood, wind or lightning
- vandalism
- fair wear and tear

INIM Electronics s.r.l. shall, at its option, repair or replace any defective products. Improper use, that is, use for purposes other than those mentioned in this manual will void the warranty. Contact Our authorized dealer, or visit our website for further information regarding this warranty.

Limited warranty

INIM Electronics s.r.l. shall not be liable to the purchaser or any other person for damage arising from improper storage, handling or use of this product.

Installation of this Product must be carried out by qualified persons appointed by INIM Electronics. Installation of this Product must be carried out in accordance with Our instructions in the product manual.

Copyright

The information contained in this document is the sole property of INIM Electronics s.r.l.

No part may be copied without written authorization from INIM Electronics s.r.l.

All rights reserved.

Table of contents

	Warranty.....	2
	Limited warranty.....	2
	Copyright.....	2
	Table of contents	3
Chapter 1	General information	5
1.1	Manufacturer's details	5
1.2	Supplied Documentation	5
1.3	About this manual	5
1.4	Operator classification - Access Levels	6
1.5	CE Mark.....	7
Chapter 2	General Description.....	9
2.1	Previdia Max System	9
2.2	Single cabinet control panel	10
2.3	Remote user interfaces (repeaters)	11
2.4	Multi-cabinet control panels	11
2.5	Control panels in a Hornet+ network	11
2.6	Control Panels in an IP network.....	11
2.7	List of Previdia Max system components	12
Chapter 3	Description of the Previdia Max system parts.....	13
3.1	PRCAB, cabinet.....	13
3.2	PRCABSP, PRCABRK, accessories for mounting the cabinet.....	14
3.3	PRREP, repeater enclosure	15
3.4	FPMCPU, front-plate CPU module and repeater.....	15
3.5	FPMLED, FPMLEDPRN, LED and printer front-plate module.....	17
3.6	IFM24160, power-supply module.....	18
3.7	IFM2L, internal module with 2 loops.....	19
3.8	IFMLAN, internal Ethernet module	20
3.9	IFMDIAL, internal dialler module	21
3.10	IFMEXT, FPMEXT, internal module and LED panel for extinguishment control.....	22
3.11	IFMNET, internal network connection module.....	26
3.12	IFM4R, internal module with 4 relays	27
3.13	IFM4IO, internal module with 4 input/output terminals.....	28
3.14	IFM16IO, internal module with 16 input/output terminals	29
Chapter 4	Previdia216 Control Panel.....	30
4.1	Inside the package	30
Chapter 5	Installation	31
5.1	Mounting a PRCAB cabinet	31
5.2	Mounting a PRREP, repeater enclosure	33
5.3	Mounting FPM modules to the front plate	33
5.4	Mounting IFM internal modules	34
5.5	Control panel wiring.....	34
5.6	IFM24160 module wiring	36
5.7	IFM2L internal module wiring - loop connection.....	38
5.8	IFMNET internal module wiring - Hornet+ network connection.....	39
5.9	IFM4R internal module wiring.....	39
5.10	IFM4IO internal module wiring.....	40
5.11	IFMDIAL internal module wiring.....	42
5.12	IFM16IO internal module wiring.....	42
5.13	IFMLAN internal module wiring.....	43
5.14	IFMEXT internal module wiring.....	43

5.15	J and E type relay output wiring (EN54)	44
5.16	FPMCPU front-plate module wiring - repeater connection.....	45
	System test.....	47
	Replacement and disposal of used devices	47
	Information about disposal of batteries and accumulators.....	47

General information

1.1 Manufacturer's details

Manufacturer: INIM ELECTRONICS s.r.l

Production plant: Centobuchi, via Dei Lavoratori 10
63076, Montepandone (AP), Italy

Tel.: +39 0735 705007

Fax: +39 0735 704912

E-mail: info@inim.biz

Web: www.inim.biz

The persons authorized by the manufacturer to repair or replace the parts of this system, hold authorization to work on INIM Electronics brand devices only.

1.2 Supplied Documentation

Previdia Max User's Manual: contains the identification of the parts on the front plate and the end-user operating instructions for use.

Previdia216 Installation Manual: contains the technical specifications of the Previdia216 and the mounting, installation and wiring instructions.

Previdia Max Installation Manual: contains the technical specifications of the system components, the description of the system applications and use, instructions for the installation of the system components with wiring instructions complete with wiring diagrams for the various modules. contains the instructions for system commissioning.

Manual for system configuration, commissioning and maintenance: contains the instructions for system commissioning and the operations to be carried out during commissioning, maintenance and troubleshooting sessions.

Manual for system programming: contains the control panel configuration guide and a detailed description of the various options contained in the programming software.

Installation manual for IFM modules: contains instructions for installation and the wiring diagrams for the various internal modules (IFM2L, IFMNET, IFM4R, IFM4IO, IFMDIAL, IFM16IO, IFMLAN, IFMEXT)

Installation manual for FPM modules: contains instructions for installation and the wiring diagrams for the various internal modules (FPMCPU, FPMLD, FPMLDPRN, FPMEXT, FPMNUL)

Instructions for the installation of accessory components: contains instructions for mounting accessory components (PRCAB, PRREP, PRCABSP, PRCABRK)

Guide to Networking: contains instructions for the connection of control panels in a Hornet network or via IP, with the description of the system limits and responsibilities relating to network use.

Guide for MODBUS usage: register map and MODBUS RTU and IP specifications.

The manuals which are not supplied with the apparatus can be ordered using their respective codes, or downloaded from www.inim.biz.

1.3 About this manual

Manual code: DCMIINEOPREVIDIA

Version: 120

1.3.1 Terminology

Control panel, System, Device: The main supervisory unit or any constituent part of the fire detection system.

Left, Right, Behind, Above, Below: Directions as seen by the operator when directly in front of the mounted device.

Qualified personnel: Persons whose training, expertise and knowledge of the products and laws regarding security systems, are able to create, in accordance with the requirements of the purchaser, the most suitable solution for the protected premises.

Select: Click on a specific item on the interface (drop-down menu, options box, graphic object, etc.).

Press: Push a button/key or tap on a video button on a touchscreen or display.

1.3.2 Graphic conventions

Following are the graphic conventions used in this manual.

Conventions	Example	Description
Text in Italics	Refer to <i>paragraph 1.3.2 Graphic conventions</i>	Directs you to the title of a chapter, section, paragraph, table or figure in this manual or other published reference.
<text>	<AccountCode>	Editable field
[Uppercase letter] or [number]	[A] or [1]	Reference relating to a part of the system or video object.

Note: *The notes contain important information relating to the text.*

Attention: *The "Attention" prompts indicate that total or partial disregard of the procedure could damage the device or its peripherals.*

EN54: Such indications indicate that the information and instructions refer to European standards.

Cables: Such indications state the types and specifications of the cables which must be used for the wiring in accordance with the manufacturer's advice or the standard concerned.

1.4 Operator classification - Access Levels

The control panel has 4 distinct access levels:

Level 1: Public level - this is the normal access level of the control panel and is the access level for building inhabitants who are neither authorized to use the system nor instructed in its use.

This level allows building inhabitants to view information on the screen and signalling LEDs, interact with the system (in accordance with Level 1) and scroll through the information by means of the buttons and touchscreen. Level 1 allows the following operations only:

- mute buzzer
- test signalling LEDs
- activate alarm signalling when an early-warning process is running

Level 2: Authorized users - this access level is for the system supervisors and is for authorized personnel who are adequately instructed in the use of the system and its functions.

Access requires the use of a key or entry of a valid access code with sufficient access rights. In addition to the operations described for level 1 it is also possible to carry out the following operations:

- mute alarm signalling devices
- rearm the control panel
- activate alarm signalling devices manually
- disable control panel elements
- place in test status one or more of the system elements

Level 3: Programming - this access level is for specialized technical operators who carry out system configuration, commissioning and maintenance.

Access requires entry of a valid access code with sufficient access rights after inserting a jumper which enables programming. Refer to the manual for system configuration, commissioning and maintenance.

ONLY authorized technicians, appointed by the Manufacturer can, by means of special tools, carry out repair work on the motherboard.

Level 4: ONLY authorized technicians, appointed by the Manufacturer can, by means of special tools, carry out repair work on the motherboard.

1.5 CE Mark

1.5.1 Regulation (EU) No. 305/2011

This product complies with requirements stated by standards listed here below in compliance with Regulation (EU) No. 305/2011.

 0832
INIM Electronics s.r.l. Via Fosso Antico snc - Fraz. Centobuchi 63076, Montepandone (AP) - Italy 16 0832-CPR-F1342
EN 54-2:1997 + A1:2006 EN 54-4:1997 + A1:2006 EN 54-2:-21 + A1:2006 EN 12094-1:2003, PREVIDIA216 PREVIDIA216R <i>Control and indicating equipment with power supply equipment, alarm transmission and fault warning routing equipment and electrical automatic control and delay device integrated for fire detection and fire alarm systems installed in buildings and for gas extinguishing systems installed in buildings and part of a complete system.</i>

Essential features	Performance	
Performance in the event of fire	PASS	
Power supply performance	PASS	
Response delay (response time in the event of fire)	PASS	
Performance of the transmission	PASS	
Operating reliability	PASS	
Durability of reliability	Thermal resistance	PASS
	Vibration resistance	PASS
	Humidity resistance	PASS
	Electrical stability	PASS
Options provided in accordance with EN54-2	Performance	
7.8 Output to fire alarm devices	PASS	
7.9 Output to fire alarm routing equipment	PASS	
7.10 Output to fire protection equipment	PASS	
7.11 Delay on outputs	PASS	
7.12 Co-incident detection (Type A, B and C)	PASS	
7.13 Alarm counter	PASS	
8.3 Point fault signal	PASS	
8.9 Output to remote fault or warning signalling devices	PASS	
9.5 Addressable points out-of-service	PASS	
10.0 Test condition	PASS	
Options provided in accordance with EN12094-1	Performance	
4.17 Delay of extinguishing signal	PASS	
4.18 Signal representing the flow of extinguishing agent	PASS	
4.19 Monitoring of the status of components	PASS	
4.20 Emergency hold device	PASS	
4.21 Control of flooding time	PASS	
4.22 Initiation of secondary flooding	PASS	
4.24 Triggering signals to equipment within the system	PASS	
4.26 Triggering of equipment outside the system	PASS	
4.27 Emergency abort device	PASS	
4.28 Control of extended discharge	PASS	
4.29 Release of the extinguishing media for selected flooding zones	PASS	
Additional information according to EN 54-2		
About information required at point 12.2.1, see data contained in this manual.		
Additional information according to EN 54-4		
About information required at point 7.1, see data contained in this manual.		
Additional information according to EN 54-21		
About information required at point 7.2.1, see data contained in this manual.		
Additional information according to EN 12094-1		
Environmental class: A Degree of protection: IP30 Flooding zones: up to 24 Zones from 1 a 24 for CO2, inert gas or halogenated hydrocarbons. Response delay activation condition: max 3s Response delay triggering of outputs: max 1s		

1.5.2 Directive 1999/5/EC

Hereby, INIM Electronics S.r.l. declares that these Previdia216 and Previdia216R with IFMDIAL module are in compliance with the essential requirements and other relevant provisions of Directive 1999/5/EC.

Following paragraph explains how to download the complete Declaration of Conformity.

This product may be used in all EU Countries.

1.5.3 Documents for the users

Declarations of Performance, Declarations of Conformity and Certificates concerning to INIM Electronics S.r.l. products may be downloaded free of charge from the web address www.inim.biz, getting access to Extended Access and then selecting "Certifications" or requested to the e-mail address info@inim.biz or requested by ordinary mail to the address shown in *paragraph 1.5.1*.

Manuals may be downloaded free of charge from the web address www.inim.biz, getting access to Extended Access and then selecting "Manuals".

General Description

2.1 Previdia Max System

Previdia Max is a modular system for the construction of fire detection and extinguishant systems.

The three typical system applications are:

- control panel in single cabinet
- control panel in several cabinets (multi-cabinet system)
- Control panels in a network (via RS485 BUS, TCP-IP connection or by means of a combination of both)

Previdia Max control panels, installed in several cabinets, are a combination of modules. Two types of modules are available:

• FPM Modules

modules to be mounted on the cabinet front plate:

- FPMCPU, main CPU unit, essential for system functioning if required, a second CPU unit can be installed inside the cabinet. This second CPU will take over in the event of fault status on the main unit and by so doing will disable the main CPU completely.
- FPMNUL - plastic support (provide no functions other than support)
- FPMLED - signalling module with 50 individually programmable tricolour LEDs
- FPMLEDPRN - signalling module with 50 individually programmable tricolour LEDs and an 80mm printer
- FPMEXT - extinguishant channel status module, to be used when the control panel is equipped with modules for the management of automatic fire-extinguishant systems (IFMEXT).



•IFM Modules

internal modules, to be mounted inside the cabinet by means of the CAN drive bar:

- IFM24160 - power supply module, essential for control panel functioning, to be mounted in the first position at the top on the CAN drive bar
- IFM2L - module for the management of two loop circuits for devices distributed in the protected area.
- IFM4R - module with 4 programmable relays
- IFM4IO - module with 4 supervised power inputs/outputs
- IFMDIAL - module for dialler communications over PSTN or GSM networks and GPRS connection management
- IFM16IO - module with 16 low-power inputs/outputs
- IFMNET - module for the connection of control panels in a Hornet+ network
- IFMLAN - module for advanced TCP-IP service management (Video verification, Web Interface Web, e-mail, etc.)
- IFMEXT - module for gas-extinguishant system management

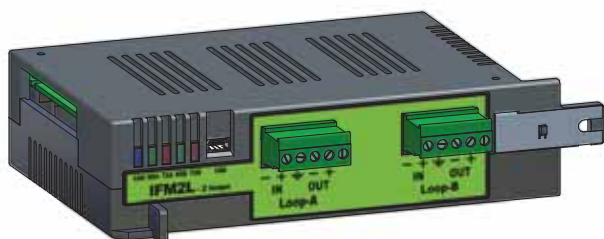

Each cabinet can house two front-plate modules and 8 internal modules.

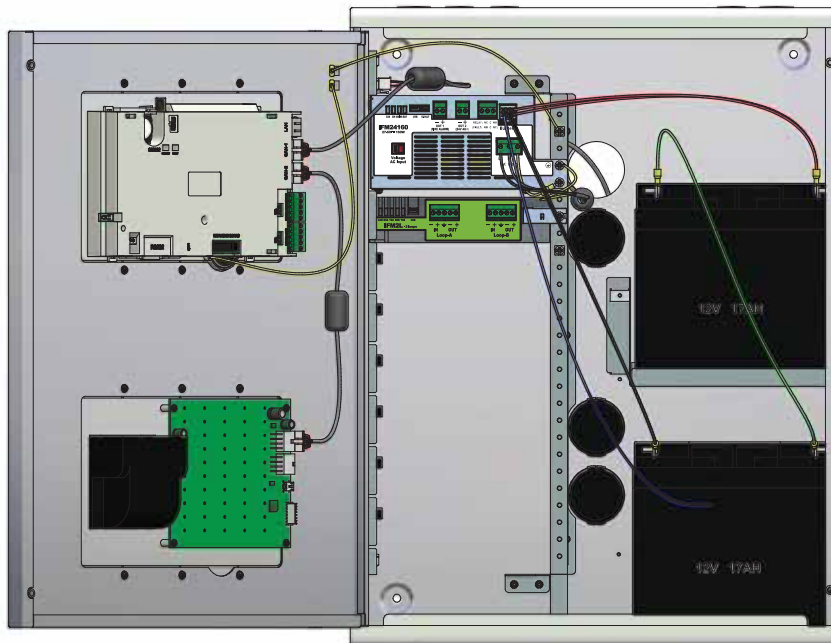

The Previdia Max control panel can be mounted in up to 4 cabinets affixed together. In a system with more than one cabinet, the maximum number of modules is as follows:

FPM Module	maximum number	IFM Module	maximum number
FPMC100	2	IFM24160	4 one per cabinet
FPMNUL	7	IFM2L	8
FPMLED	7	IFM4R	16
FPMLEDPRN	1	IFM4IO	16
FPMEXT	5	IFMDIAL	1
		IFM16IO	4
		IFMNET	1
		IFMLAN	1
		IFMEXT	24

2.2 Single cabinet control panel

If the Previdia Max system is mounted in a single cabinet with a main FPMC100 unit (crucial for system functioning), it will be possible to install a second FPM module on the front plate.

The cabinet has a CAN drive inside for the interconnection of a maximum of 8 IFM modules, installed in accordance with system requirements.

Previdia216, the basic Previdia Max control-panel model mounted in a single cabinet already has the following modules installed:

- Main CPU unit
- IFM24160 - power-supply module
- IFM2L - module for the management of two loops



2.3 Remote user interfaces (repeaters)

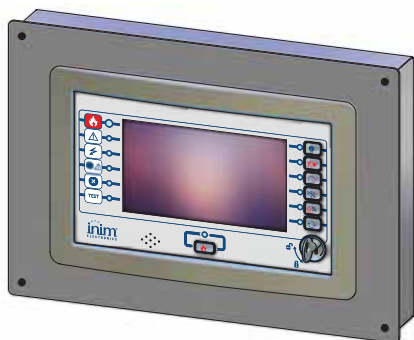

The FPMCPU unit has an RS485 BUS which supports up to 15 repeater user interfaces.

Each repeater provides the same functions as the FPMCPU module. Each repeater is constituted by an FPMCPU unit housed in an enclosure with a cover plate (PRREP). During the configuration phase each unit must be included in the system as a repeater.

For the installation instructions refer to *paragraph 5.2 Mounting a PRREP, repeater enclosure*; for the electrical connections refer to *paragraph 5.16 FPMCPU front-plate module wiring - repeater connection*.

Repeaters can be connected to the system also through a TCP-IP connection (refer to *paragraph 2.6 Control Panels in an IP network*).

2.4 Multi-cabinet control panels

The capacity of the control panel can be expanded by affixing as many as 4 cabinets together.

The cabinets can be affixed together by securing the bottom of one cabinet to the top of another by means of the supplied bolts. Once the cabinets are affixed to one another, all the CAN drive bars must be connected together by means of the supplied BUS cable.

The number of housings available for front-plate and internal modules increases with the number of cabinets installed.

An IFM24160 power supply module can be installed in each of the cabinets, thus providing a voltage equal to the sum of the maximum voltages of the power-supply modules installed. Power-supply modules installed in this way share the voltage load automatically.

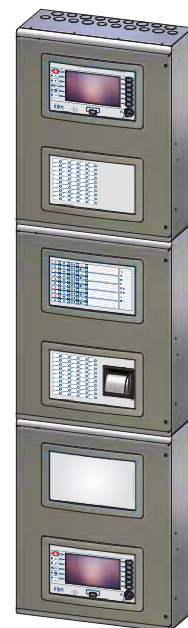

2.5 Control panels in a HorNet+ network

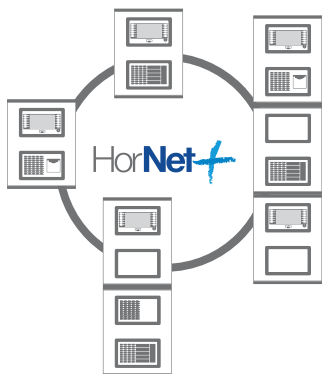

The system can be expanded by simply connecting other control panels (maximum 48) in such a way as to constitute a system with increased capacity (Hornet+ network).

When connecting two or more control panels in a HorNet+, it will be necessary to install an IFMNET module inside each control panel. These modules provide two RS485 ports for the loop (for the wiring description refer to *paragraph 3.11 IFMNET, internal network connection module*).

For further information regarding the method used for connecting control panels in a network refer to the Previdia Max Networking Guide available at www.inim.biz

2.6 Control Panels in an IP network

Several control panels or HorNet+ networks of control panels can be connected together by means of a TCP-IP connection.

Each node in a connection of this type is identified as a "cluster". Each cluster can consist of a single control panel, a HorNet network of control panels or a repeater.

For further information regarding the method used for connecting control panels in a network refer to the Previdia Max Networking Guide available at www.inim.biz

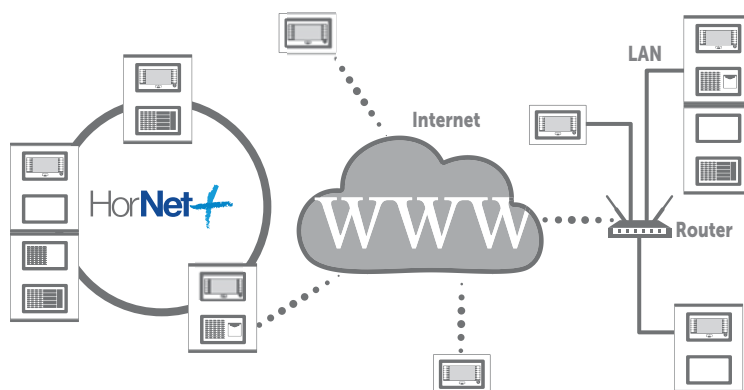

2.7 List of Previdia Max system components

Following is a list of the elements available for the Previdia Max system:

- Basic Previdia Max control panels:
 - Previdia216 Control panel comprising a metal cabinet complete with front plate, CPU unit, power-supply module, 2 loop module and a blind plate to seal the aperture on the front of the cabinet.
 - Previdia216R As per Previdia216 but comes in red cabinet
- IFM internal modules:
 - IFM24160 CAN power-supply module
 - IFM2L CAN module with 2 loops
 - IFMNET CAN module for Hornet+ network connections
 - IFM4R CAN module with 4 relays
 - IFM4IO CAN module with 4 I/O
 - IFMDIAL CAN dialler module
 - IFM16IO CAN module with 16 I/O
 - IFMLAN CAN LAN module
 - IFMEXT CAN extinguishant module
- FPM front-plate modules:
 - FPMCPU CPU / Repeater module
 - FPMLED LED module
 - FPMLEDPRN LED module with printer
 - FPMEXT LED module for extinguishant module
 - FPMNUL Blind-plate module
- Cabinets:
 - PRCAB Metal cabinet complete with front plate
 - PRCAB-R Metal cabinet complete with front plate, in red
- Accessories:
 - PRREP Enclosure and front plate in aluminium for repeaters
 - PRCABSP Kit for distancing the cabinet from the wall
 - PRCABSP-R Kit for distancing the cabinet from the wall, in red
 - PRCABRK Kit for mounting cabinet to 19" rack

Description of the Previdia Max system parts

3.1 PRCAB, cabinet

The PRCAB cabinet is a metal enclosure equipped with a front plate (door) with removable hinges. The cabinet can be wall mounted and anchored in place using the holes on the back of the enclosure or can be affixed to another cabinet by means of two bolts and the holes on the top and bottom sides of the enclosure.

The front of the cabinet provides two apertures for mounting two FPM front-plate modules and the grounding connections.

It has a compartment for the connection of up to 8 IFM modules via a CAN drive bar equipped with connectors for IFM internal modules, and a CAN BUS cable for communication with the FPM front-plate modules or affixed cabinets. The compartment has a bar which serves to hold the modules in place and allows the grounding connections. There is a placement for two 12V, 24Ah or 17Ah batteries.

The cabinet has hooks for the cable ties and cable entries on the top and bottom sides. Appropriate hole covers are provided.

The cabinet is also available in red and can be ordered using the following code: PRCAB-R.

The available accessory items, required in accordance with the type of installation, are as follows:

- PRCABSP kit for mounting the cabinet at a distance of 5cm from the wall, also available in red (PRCABSP-R)
- PRCABRK kit for mounting the cabinet to a rack, also available in red (PRCABRK-R)

PRCAB comes with:

- CAN drive bar (inserted)
- Hole covers (inserted)
- 2 bolts for affixing cabinets together
- CAN BUS cable
- Ground connection wire
- Instructions manual

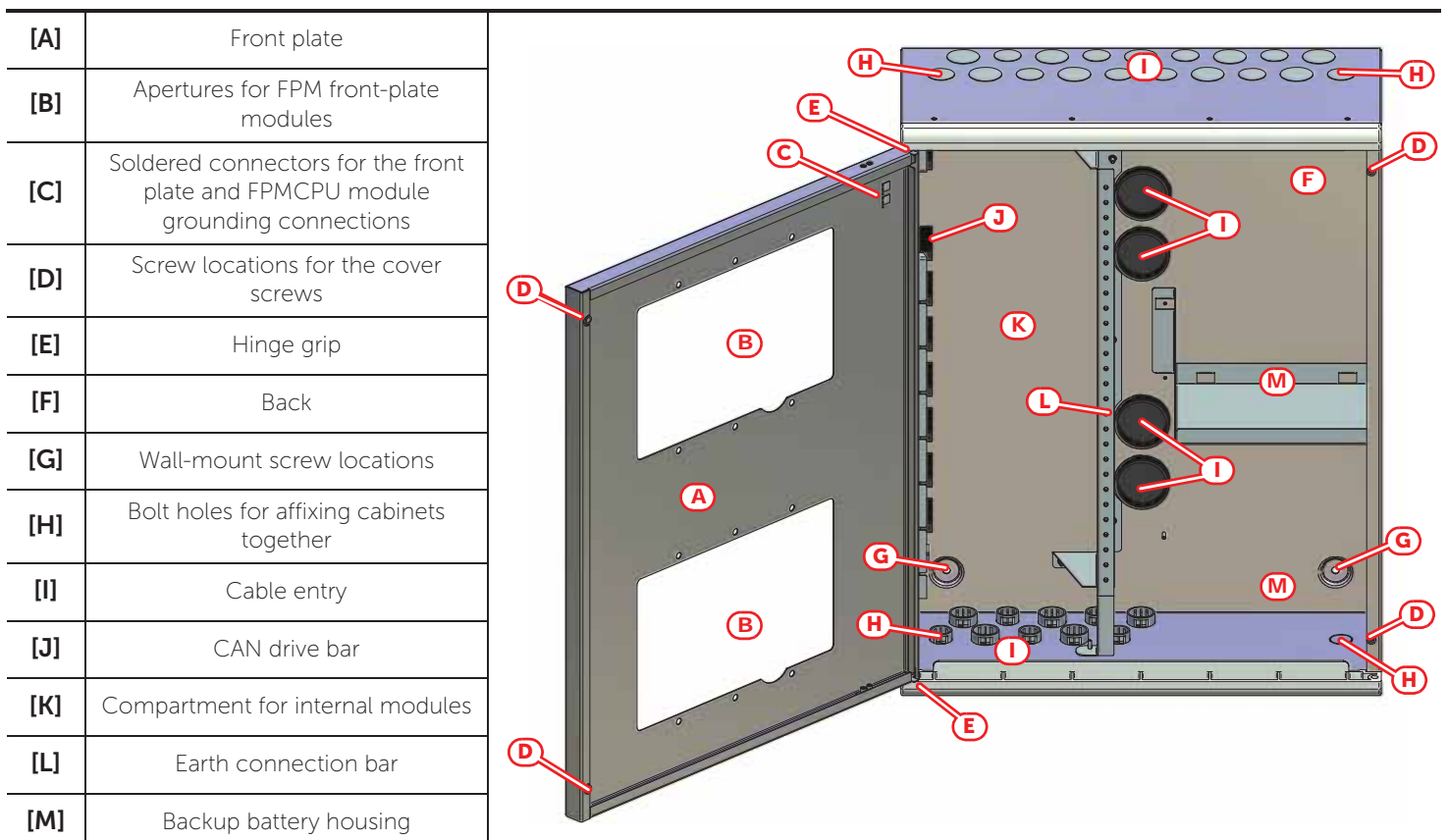

[N]	PCB CAN drive	
[O]	CAN connector	to the CAN drive bar of an upper cabinet
[P]		to the module on the front plate
[Q]		to the CAN drive bar of a lower cabinet
[R]	Connector for IFM internal module	to the power-supply module, if present or any module
[S]		for all modules except the power supply module

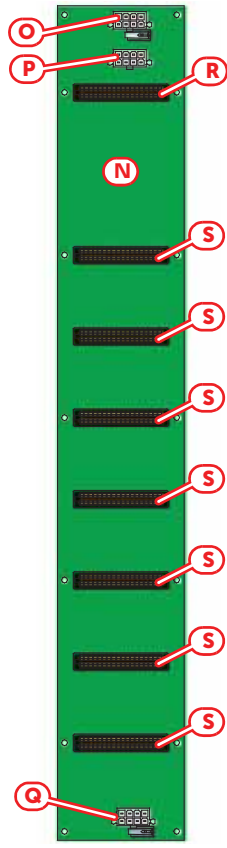

PRACAB - technical specifications	
Dimensions	433 x 563 x 187 mm
Weight	10Kg
Protection rating	IP30
Accepted Batteries	2 x 12V 24Ah, NPL24-12I or equivalent or 2 x 12V 17 Ah, NP 17 -12-FR or equivalent

3.2 PRCABSP, PRCABRK, accessories for mounting the cabinet

The PRCABSP kit allows you to distance the cabinet 5cm from the wall thus creating a space between the cabinet and its placement. Consists of three pieces to be assembled together before mounting the control panel cabinet.

The PRCABRK kit allows you to mount the cabinet to a 19" rack by means of two support brackets at each side of the cabinet.

PRCABSP, PRCABRK come complete with:

- 4 nuts with washers
- Instructions manual

The PRCABSP kit is also available in red.

PRCABSP	[A]	Distance bracket/template
	[B]	Support bracket
	[C]	Wall-mount screw location
	[D]	Dovetail locations
	[E]	Threaded rivet
PRCABRK	[F]	Support bracket (2)
	[G]	Rack anchor-screw locations
	[H]	Threaded rivet

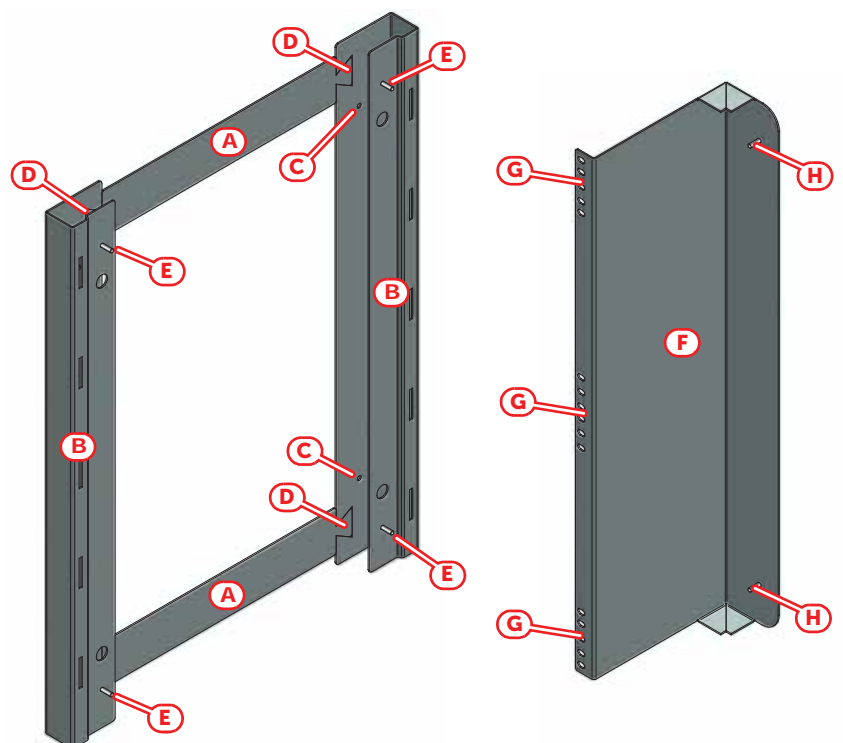

3.3 PRREP, repeater enclosure

A remote repeater user-interface can be housed either inside a PRCAB cabinet or inside a PRREP mounting enclosure.

These enclosures can be wall mounted using the anchor-screw holes, or flush-mounted using the flanges available on the back of the enclosure.

PRREP provides a front plate in aluminium for the mounting of an FPMCPU front-plate module.

[A]	Front plate
[B]	FPMCPU module aperture
[C]	Screw locations for the panel screws
[D]	Screw locations for the FPMCPU module screws
[E]	Speaker position
[F]	Flush-mount box
[G]	Cable entry
[H]	Wall-mount screw locations
[I]	Flush-mount flange knockouts

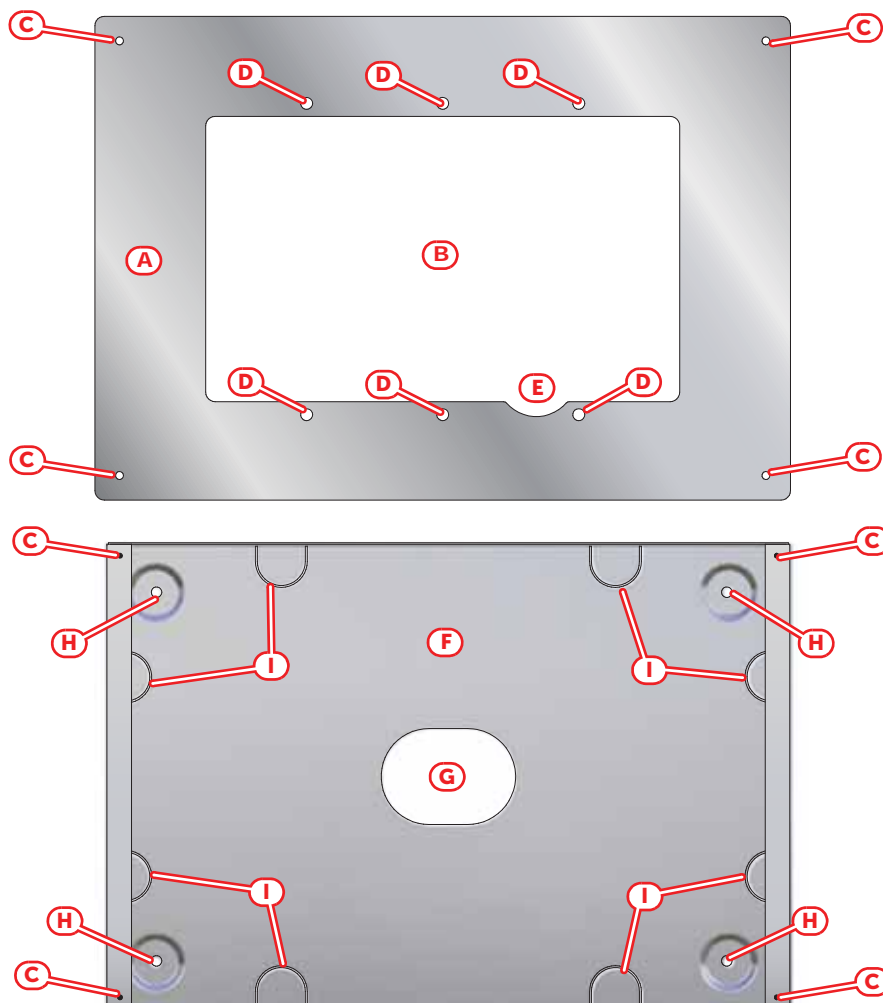

PRREP - technical specifications

Dimensions	Front plate	368 x 256 x 2.5 mm
	Flush-mount enclosure	356 x 244 x 56 mm
Weight		250g

3.4 FPMCPU, front-plate CPU module and repeater

The FPMCPU module is the main unit of the control panel and contains the main CPU with all the system configuration data.

Each module in the Previdia Max system has its own independent CPU. Each FPMCPU unit contains two CPUs: a main CPU and a emergency backup CPU. The backup CPU will take over in the event of fault on the main CPU.

The emergency backup CPU ensures the efficiency of the basic functions of the system (alarm signal reception from points and activation of outputs). However, it does not ensure all the configured activation logic. For total redundancy of all the configured functions, it is necessary to add and configure a second FPMCPU unit to the control panel.

The FPMCPU front-plate module has three operating modes:

- main unit of the control panel
- backup unit
- remote repeater user-interface

FPMCPU comes with:

- CAN BUS cable
- 6 screws with washers for securing the module
- 2 system access keys
- 2 ferrites
- Instructions manual

[A]	Touchscreen display
[B]	Status LED
[C]	LED and function button
[D]	LED and multiple-alarm button
[E]	Access-key slot
[F]	Speaker
[G]	Ground connection wire
[H]	Mounting screw locations
[I]	CR2032 battery (included, for internal clock)
[J]	MicroSD card holder
[K]	Button to reset default settings (factory settings)
[L]	Reset button
[M]	Ethernet port
[N]	CAN bar connector
[O]	Connector for other front-plate module
[P]	RS485 terminal board for repeaters
[Q]	EOL jumper connectors
[R]	RS485 MODBUS terminal board
[S]	MODBUS EOL jumper connectors
[T]	For future use
[U]	USB mini port

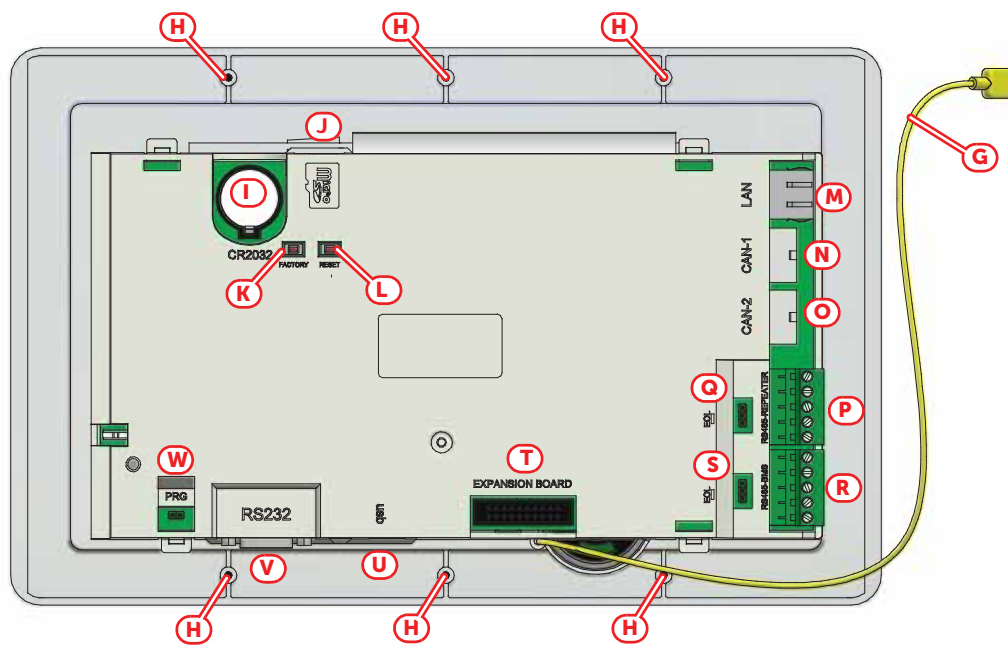
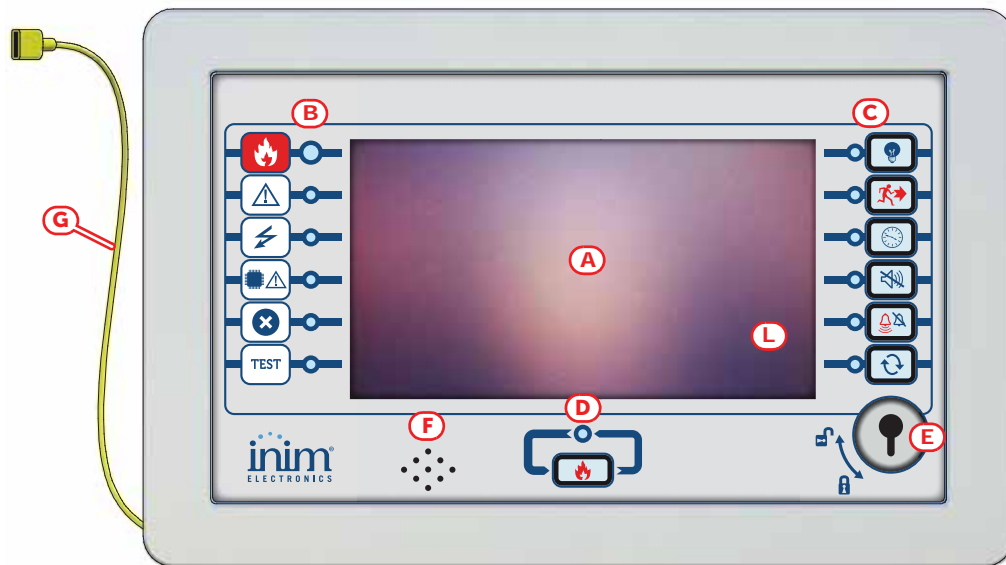

[V]	Serial connector
[W]	programming jumper connectors

FPM-CPU module - technical specifications

Power supply voltage		19-30V $\overline{=}$ supplied by IFM24160 module
Operating temperature		from -5°C to +40°C
Consumption @ 27.6V	stand-by	130mA
	maximum	140mA
	mains fault	110mA
Maximum voltage on RS485-REPEATER		1A @ 27.6V $\overline{=}$
Maximum voltage on RS485-BMS		1A @ 27.6V $\overline{=}$

3.5 FPMLED, FPMLEDPRN, LED and printer front-plate module

The FPMLED and FPMLEDPRN front-plate modules are equipped with 50 tricolour LEDs which replicate the signals generated by the system.

The FPMLEDPRN module is equipped with an 80mm thermal printer.

This module mounts to either of the two apertures on the front of the cabinet and connects to the system via the CAN bus cable. Each module is equipped with:

- CAN BUS cable
- 6 screws with washers for securing the module
- 1 ferrite
- Instructions manual

[A]	LED
[B]	Thermal printer
[C]	Mounting screw locations
[D]	Connector for the CAN drive bar or other front-plate module
[E]	Connector for front-plate module
[F]	Mini USB port
[G]	Label with firmware revision of the module

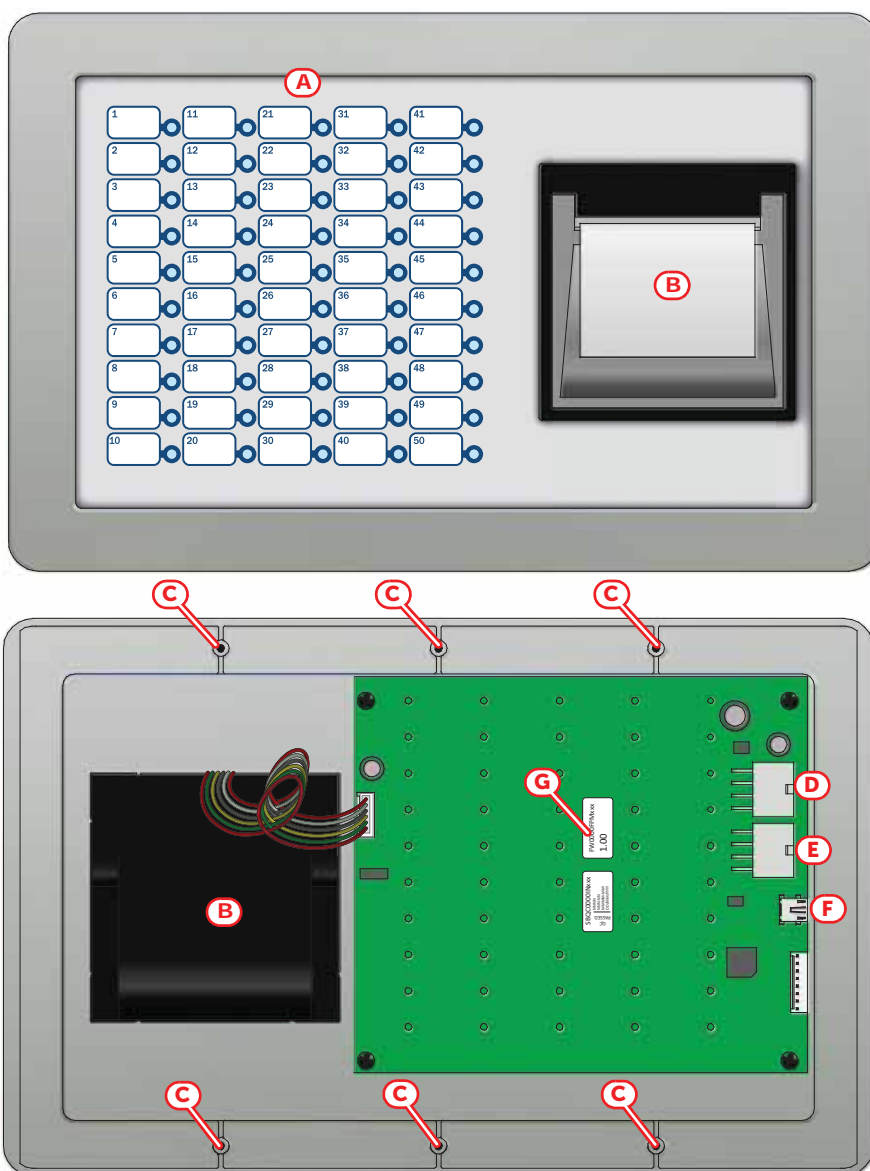

Technical specifications		FPMLED module	FPMLEDPRN module
Power supply voltage		19-30 V $\overline{\text{DC}}$ supplied by IFM24160 module	
Operating temperature		from -5°C to +40°C	
Consumption @ 27.6V	stand-by	12mA	35mA
	maximum	45mA	400mA

3.6 IFM24160, power-supply module

The IFM24160 internal module supplies and distributes power through the CAN drive connection bar and through the two outputs, OUT 1 and OUT 2.

In installations where several control panels are connected in a network, it is necessary to use an IFM24160 power-supply module for each control panel.

In installations where the control panel comprises more than one cabinet, you can install a power supply in each cabinet. The total voltage available equals the sum of the voltages of each power supply added together minus 1A for correct cable balance.

FPMCPU comes with:

- battery connection wire with thermal probe
- battery to battery connection wire
- 3 screws for securing the module to the grounding bar
- wire with eyelet terminal for connection to earth
- 1 ferrite
- Instructions manual

[A]	Status LED				
[B]	Mini USB port				
[C]	Jumper connectors for enablement of the ground-fault test				
[D]	OUT 1	Supervised output			
[E]	OUT 2				
[F]	RELAY	Relay - voltage free contact			
[G]	Battery connector				
[H]	L N $\overline{\text{PE}}$	AC Mains input terminals			
[I]	$\overline{\text{PE}}$	Hole for the grounding bar screw and for the earth conductor			
[J]	Hole for the grounding bar screw and for the wire with the eyelet terminal				[K]
			[L]	CAN drive connector (opposite)	

The indications in brackets below terminals OUT1, OUT2 and RELAY [D, E, F] show the respective factory default settings.

IFM24160 LED	Colour	On solid	Flashing
CAN	Blue	Activity on the CAN communication BUS	
ON	Green	Module operating normally	Slow flashing: overload (system voltage draw is excessive) Fast flashing: PSU unit overheated
MAINS	Yellow	Mains failure fault	Fast flashing: system ground fault
BATT	Yellow	Battery inefficiency or fault	

IFM24160 module - technical specifications

Power supply voltage	230V~ (+10% - 15%) 115V~ (+10% - 15%) 50/60 Hz	
Maximum current draw from mains	1.1A @ 230V 2A @ 115V	
Output voltage	27.6 V ⁻⁻⁻ nominal 20 - 27.6 V ⁻⁻⁻	
Maximum output ripple	1%	
Maximum available current	5.2A	
I _{max a} (as per EN54-4)	4A	
I _{max b} (as per EN54-4)	4A	
I _{min}	185mA	
Batteries	2 x 12 V 24Ah, NPL24-12I or 2 x 12 V 17 Ah, NP 17 -12-FR or equivalent with UL94-V1 flame class enclosure or higher	
Battery charger Maximum voltage charge adapted to temperature	1.2A	
Maximum internal resistance of battery (R _i Max)	10Ohm	
Battery shutdown voltage	19.5V	
Operating temperature	from -5°C to +40°C	
Isolation class	I	
Consumption @ 27.6V	stand-by	20mA
	maximum	40mA
Maximum voltage on OUT 1	1.5A @ 27.6V ⁻⁻⁻	
Maximum voltage on OUT 2	1.5A @ 27.6V ⁻⁻⁻	
Maximum voltage on RELAY	5 A @ 30V ⁻⁻⁻	

3.7 IFM2L, internal module with 2 loops

All the peripheral devices of the system must be connected in parallel to the loop circuit (2 pole shielded cable). The control panel communicates with the loop devices via a digital protocol which allows their complete control. The loop utilizes the same two wires for the power supply to devices and for two-way communication.

Each IFM2L module contains circuits for the management of two loops. Previdia Max control panels are capable of managing up to 16 loops through a maximum of 8 IFM2L modules.

IFM2L comes with:

- 3 screws for securing the module to the grounding bar
- Instructions manual

[A]	Status LED		
[B]	Mini USB port		
[C]	Loop-A	Loop A connection terminals	
[D]	Loop-B	Loop-B connection terminals	
[E]	Holes for the grounding bar screws		
[F]	CAN drive connector (opposite)		

LED IFM2L	Colour	On solid	Flashing
CAN	Blue	Activity on the CAN communication BUS	
RXA	Green	Reception activity - receiving data from devices on loop A	
TXA	Red	Transmission activity - transmitting data to devices on loop A	
RXB	Green	Reception activity - receiving data from devices on loop B	
TXB	Red	Transmission activity - transmitting data to devices on loop B	

IFM2L module - technical specifications

Power supply voltage	19-30 V _{DC} supplied by IFM24160 module	
Operating temperature	from -5°C to +40°C	
Maximum number of devices managed by a loop	240	
Consumption @ 27.6V	stand-by	35mA
	maximum	50mA
Maximum voltage on Loop-A	0.5A	
Maximum voltage on Loop-B	0.5A	

3.8 IFMLAN, internal Ethernet module

The IFMLAN module provides the Previdia Max with communication ports:

- USB Host
- Mini USB
- Ethernet
- RS485
- RS232

Connecting the Ethernet port establishes a second connection between the control panel and the network for access to the advanced TCP-IP functions (sending of event-related e-mails, communications via SIA-IP, video verification and browser-accessible Web server).

IFMLAN comes with:

- 3 screws for securing the module to the grounding bar
- Instructions manual
- SD card not included

[A]	Status LED	
[B]	Mini USB port	
[C]	USB port	
[D]	Ethernet port	
[E]	MicroSD card holder	
[F]	1 - 16	
[G]	Holes for the grounding bar screws	
[H]	CAN drive connector (opposite)	

Serial	Terminal	
RS232	1	Programmable ancillary power output
	2	RS232 TX
	3	RS232 RX
	4	RS232 RTS
	5	RS232 CTS
	6	Negative (GND, ⊕)
	7, 8	Earth

Serial	Terminal	
RS485	9	Programmable ancillary power output
	10	RS485 B (negative)
	11	RS485 A (positive)
	12 13	EOL
	14	Negative (GND, ⊕)
	15, 16	Earth

IFMLAN LED	Colour	On solid
CAN	Blue	Activity on the CAN communication BUS
RS485	Green	Activity on the RS485 communication BUS
RS232	Green	Activity on the RS232 communication BUS
USB FAULT	Red	Fault detected on USB port
COM	Yellow	Communicator CPU operating

IFMLAN module - technical specifications	
Power supply voltage	19-30 V ^{DC} supplied by IFM24160 module
Operating temperature	from -5°C to +40°C
Consumption @ 27.6V	45mA
Maximum capacity of SD-card	32Gbyte
Security protocol	8bit proprietary encryption
IP access address at default	192.168.1.200

3.9 IFMDIAL, internal dialler module

The IFMDIAL internal module allows Praesidia control panels to connect to the landline (PSTN) and the GSM network. It manages reporting protocols used by alarm receiving centres. This module allows the control panel to make voice calls and send SMS text messages.

IFMDIAL comes with:

- 3 screws for securing the module to the grounding bar
- Instructions manual
- SIM card and GSM antenna not included

[A]	Status LED		
[B]	Mini USB port		
[C]	GSM antenna connector		
[D]	SIM card holder		
[E]	Internal telephone line terminals PSTN Telephone line connection terminals Ground terminal	[F] Holes for the grounding bar screws [G] CAN drive connector (opposite)	

IFMDIAL LED	Colour	On solid	Flashing
CAN	Blue	Activity on the CAN communication BUS	
LINE	Yellow	Ongoing call	
	Green	GSM signal reception level	

IFMDIAL module - technical specifications

Power supply voltage	19-30 V _{DC} supplied by IFM24160 module	
Operating temperature	from -5°C to +40°C	
Consumption @ 27.6V	stand-by	30mA
	maximum	250mA
GSM band frequency	850, 900, 1800 e 1900 Mhz (Quad band)	

3.10 IFMEXT, FPMEXT, internal module and LED panel for extinguishment control

The IFMEXT and FPMEXT are fire-extinguishant system control modules and must be combined.

The internal IFMEXT module allows management of a gas extinguishant channel. Complies with EN12094-1 and provides the inputs, outputs and control logic required by fire-extinguishant systems.

The indications provided by the IFMEXT module, as well as being visualized on the FPMCPU module display, can also be seen on the LEDs on the front-plate FPMEXT module. This module has 40 tricolour LEDs which replicate the signals of up to 5 IFMEXT.extinguishant modules on the control panel front plate.

IFMEXT comes with:

- 3 screws for securing the module to the grounding bar
- 7 resistors @1kOhm 1w
- 3 resistors @ 3k9Ohm
- 3 resistors @ 470Ohm
- 4 diodes -1n4007
- Instructions manual

FPMEXT comes with:







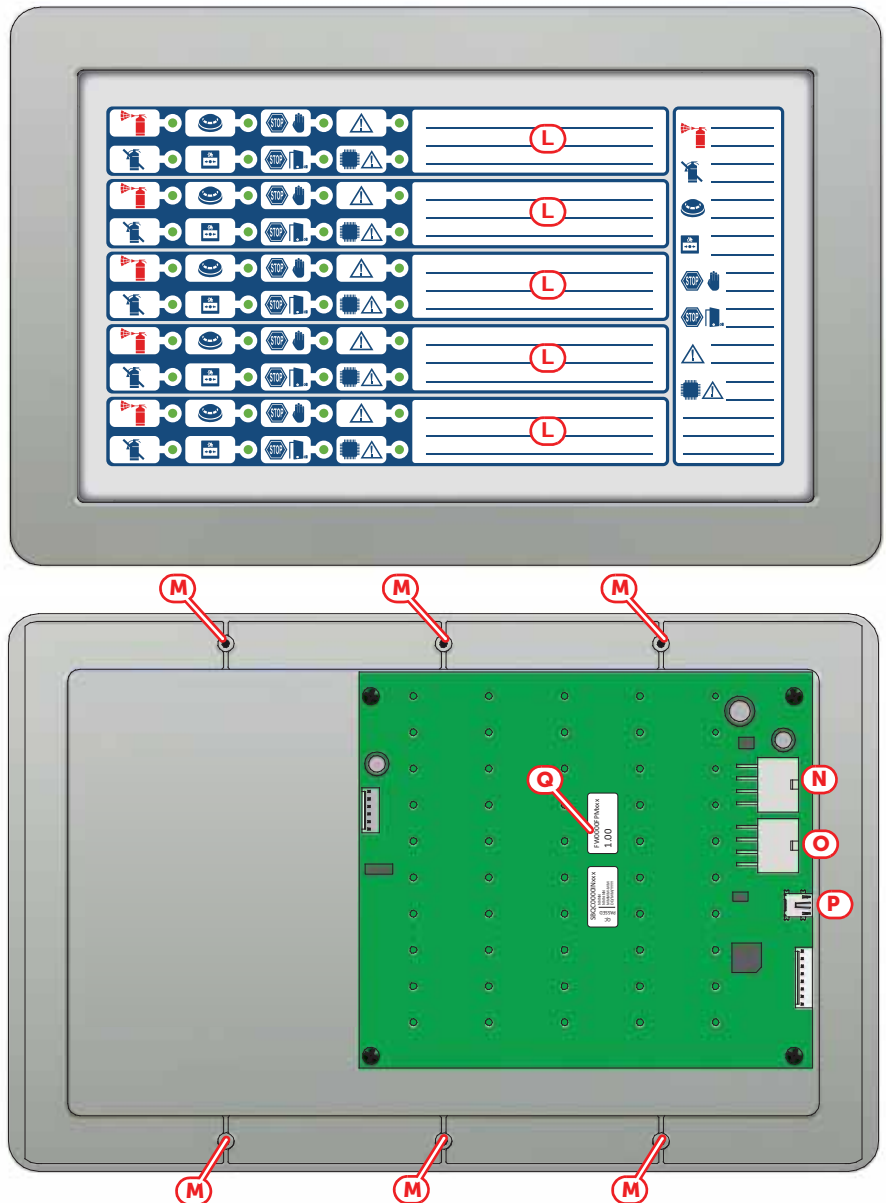

- CAN BUS cable
- 6 screws with washers for securing the module
- 1 ferrite
- Instructions manual

[A]	Status LED		
[B]	Mini USB port		
[C]	PRESSOS.		Connection terminals
[D]	STOP-EXT		
[E]	MAN.-EXT		
[F]	VALVE		
[G]	HOLD		
[H]	PRE-EXT		
[I]	RELEASED		
[J]	Holes for the grounding bar screws		
[K]	CAN drive connector (opposite)		

[L]	Visual signalling of IFMEXT modules
[M]	Mounting screw locations
[N]	Connector for the CAN drive bar or other front-plate module
[O]	Connector for front-plate module
[P]	Mini USB port
[Q]	Label with firmware revision of the module



IFMEXT LED	Colour	On solid
CAN	Blue	Activity on the CAN communication BUS
EXT	Red	Extinguishment activated (running or ended)
	Yellow	Fault on VALVE terminal line
HOLD	Red	Extinguishment locked manually or automatically
	Yellow	Fault on the line of the HOLD terminal
PRE-EXT	Red	Pre-extinguish phase running
	Yellow	Fault on the line of the PRE-EXT terminal
REL	Red	Extinguishment terminated
	Yellow	Fault on the RELEASED terminal line

FPMEXT LED	Colour	On solid	Flashing
 Extinguishment channel activation LED	Red	Discharge activated	Pre-extinguishment condition running
 Extinguishment channel disabled LED	Yellow	Channel bypassed	/
 Automatic activation LED	Red	Automatic discharge command activated	Automatic discharge command partially activated
 Manual activation LED	Red	Manual discharge command activated	/
 Manually locked extinguishment LED	Yellow	Extinguishment locked	Fault on lock-extinguishment circuit
 Lock extinguishment command LED (lock command from non-electrical-device)	Yellow	Extinguishment locked	Fault on lock-extinguishment circuit
 Generic fault LED	Yellow	/	Generic fault on extinguishment channel
 CPU fault LED	Yellow	Generic CPU fault on extinguishment module	/

IFMEXT module - technical specifications

Power supply voltage	19-30 V ^{DC} supplied by IFM24160 module	
Operating temperature	from -5°C to +40°C	
Consumption @ 27.6V	stand-by	30mA
	maximum	80mA
Maximum voltage @ 27.6V	on VALVE output	2A
	on outputs	1A

FPMEXT module - technical specifications

Power supply voltage	19-30 V ^{DC} supplied by IFM24160 module	
Operating temperature	from -5°C to +40°C	
Consumption @ 27.6V	stand-by	12mA
	maximum	45mA

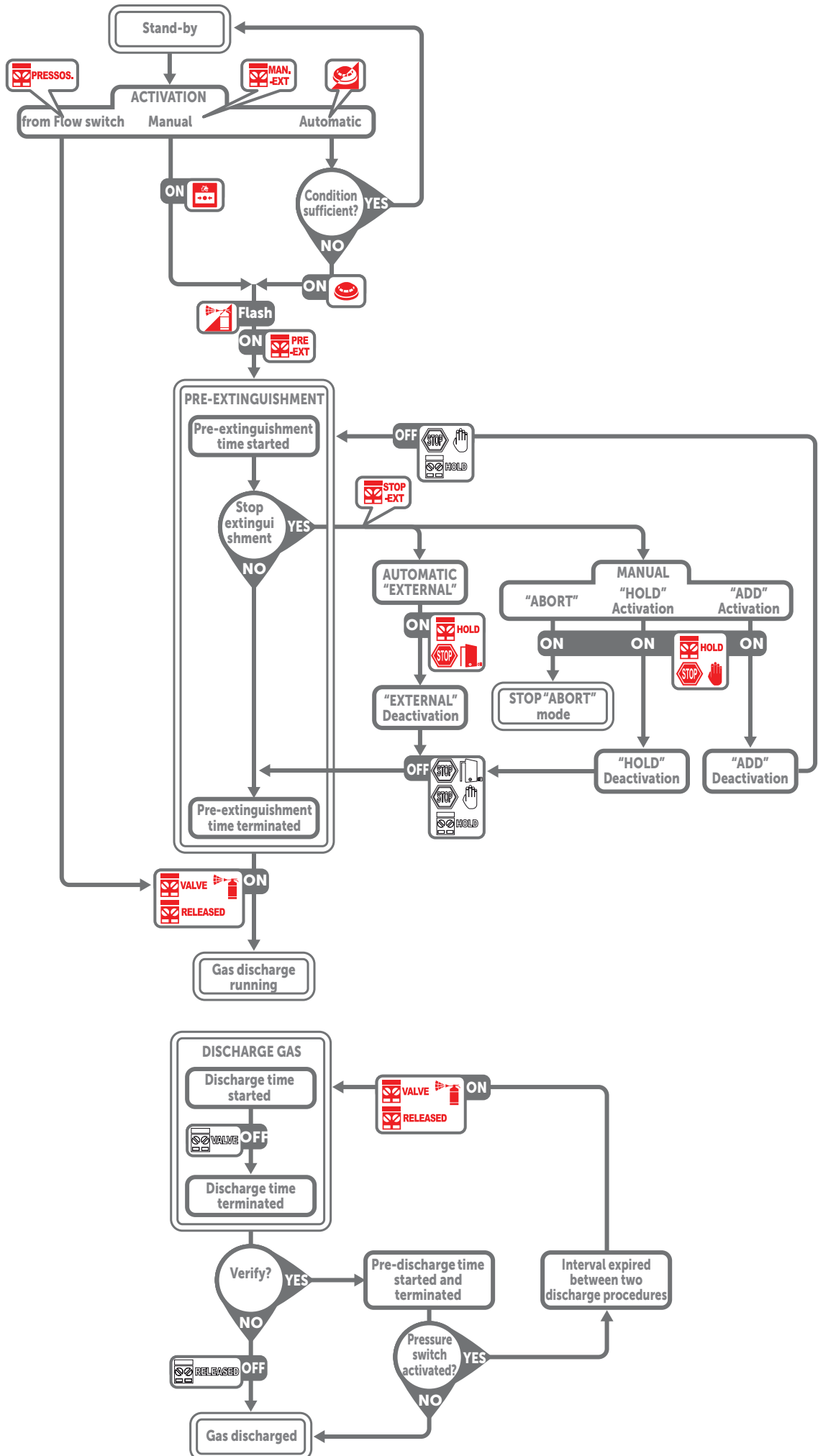

Terminal	Function	Activation	
PRESSOS.	The pressure-switch input is for the connection of a pressure switch which will close the contact in the event of low pressure in the cylinders.	If the electrovalve opens when the "verify" procedure is enabled, its activation confirms the discharge of extinguishant gas (refer to the "confirm" option below). During stand-by status, its activation generates a fault warning.	
STOP-EXT	This input stops the extinguishment procedure in accordance with the activation mode described opposite.	Abort	If this input is activated during the pre-extinguishment phase, the extinguishment procedure will be aborted even if the input resets. The procedure can be restarted only after control panel reset. If activated during stand-by, it will generate a fault warning.
		Add	If this input activated during pre-extinguishment status, the extinguishment procedure will remain locked until the input resets. On input reset the pre-extinguishment countdown will refresh and restart. If this input is activated during stand-by, it will generate a fault warning.
		Hold	If this input is activated during pre-extinguishment status, the extinguishment procedure will remain locked but the pre-extinguishment countdown will continue running. On input reset, if the early warning countdown has terminated, the extinguishant gas will be discharged. If this input is activated during stand-by, it will generate a fault warning.
		External	This function is identical to the "Hold" function but refers to mechanical or electrical intervention (for example, a door contact that inhibits gas discharge, etc.). This activation will be signalled separately. If activated during stand-by, it will not generate a fault warning.
MAN.-EXT	This input is for the connection of one or more manual call points for the activation of extinguishing-agent discharge.		
VALVE	Output for the connection of the electrovalve which discharges the extinguishing agent.	It will activate only when the pre-extinguishment time expires	
HOLD	Output for the connection of lock-extinguishment signalling devices.	It will activate when the extinguishing channel is locked by one or more inputs connected to a "STOP-EXT" input.	
PRE-EXT	Output for the connection of a signal relating to imminent discharge of the extinguishing agent.	It will activate during the pre-extinguishment time which runs before the discharge of the extinguishing agent.	
RELEASED	Output for the connection of signalling devices which warn building inhabitants of the actual discharge of the extinguishing agent.	It will activate on activation of the electrovalve.	

Note: *The functions shown in the table, with the exception of the "VALVE" output, can be replicated on the input/output devices of the loop or IFM internal modules.*

3.11 IFMNET, internal network connection module

The IFMNET module allows you to connect two or more control panels in a Hornet+ network by means of two RS485 communication ports (A and B).

In cases where a fiber optic cable is used over long BUS lengths, it is necessary to use a RS485/fiber converter (non-INIM brand product). The module has a 12V output for the power supply to the converter in use.

IFMNET comes with:

- 3 screws for securing the module to the grounding bar
- Instructions manual

[A]	Status LED		
[B]	Mini USB port		
[C]	Port-A	Connection terminal for port A	
[D]	Port-B	Connection terminal for port B	
[E]	12V	Terminals for the power supply to the RS485/fiber converter	
[F]	Holes for the grounding bar screws		
[G]	CAN drive connector (opposite)		

IFMNET LED	Colour	On solid	Flashing
CAN	Blue	Activity on the CAN communication BUS	
RXA	Green	Data reception activity on port A	
TXA	Red	Transmission activity on port A	
RXB	Green	Data reception activity on port B	
TXB	Red	Transmission activity on port B	

IFMNET module - technical specifications

Power supply voltage	19-30 V ^{DC} supplied by IFM24160 module
Operating temperature	from -5°C to +40°C
Consumption @ 27.6V	60mA
Maximum voltage on OUT 12V	0.8A for use inside the cabinet

3.12 IFM4R, internal module with 4 relays

The IFM4R module provides 4 relay outputs with voltage-free contacts (Common, Normally Open and Normally Closed). The activation mode of each relay can be defined during the system configuration phase using the configuration software.

IFM4R comes with:

- 3 screws for securing the module to the grounding bar
- Instructions manual

[A]	Status LED		
[B]	Mini USB port		
[C]	Relay-x	Connection terminals for relay output x	
[D]	Holes for the grounding bar screws		
[E]	CAN drive connector (opposite)		

LED IFM4R	Colour	On solid	Flashing
CAN	Blue	Activity on the CAN communication BUS	
OUTx	Green	Output x activated	

IFM4R module - technical specifications

Power supply voltage	19-30 V ⁻⁻⁻ supplied by IFM24160 module	
Operating temperature	from -5°C to +40°C	
Consumption @ 27.6V	stand-by	10mA
	maximum	80mA
Maximum voltage on outputs	5A @ 30V ⁻⁻⁻	

3.13 IFM4IO, internal module with 4 input/output terminals

The IFM4IO module provides 4 input/output channels (IN/OUT 1, ..., IN/OUT 4) each of which, by means of the configuration software, can be configured as:

- Supervised output, to drive alarm signalling devices or similar (also indicated as a NAC output)
- Supervised input, to control the status of a device or the acquisition of a command
- Conventional line, for interfacing with a conventional line
- 4-20mA gas detector input

IFM4IO comes with:

- 3 screws for securing the module to the grounding bar
- 4 resistors @1kOhm 1w
- 4 resistors @ 3k9Ohm
- 4 resistors @ 470Ohm
- 4 diodes -1n4007
- Instructions manual

[A]	Status LED				
[B]	Mini USB port				
[C]	IN/OUT x			Connection terminals for input/output x	
[D]	Holes for the grounding bar screws			[E]	CAN drive connector (opposite)

LED IFM4IO	Colour	On solid	Flashing
CAN	Blue	Activity on the CAN communication BUS	
I/Ox	Red	The respective channel, configured as "input", is in alarm or activated status	
	Green	The channel configured as "output" is active	
	Yellow	The channel is in fault status	

IFM4IO module - technical specifications

Power supply voltage		19-30 V ^{DC} supplied by IFM24160 module
Operating temperature		from -5°C to +40°C
Consumption @ 27.6V	stand-by	22mA
	maximum	170mA
Maximum voltage on I/O		1A @ 27.6V ^{DC}

3.14 IFM16IO, internal module with 16 input/output terminals

The IFM16IO module provides 16 channels, each of which, by means of the configuration software, can be configured as:

- Non-supervised low power output for low-demand loads
- Non-supervised input

This module also provides terminals for the ancillary power @ 27V.

IFM16IO comes with:

- 3 screws for securing the module to the grounding bar
- Instructions manual

[A]	Status LED		
[B]	Mini USB port		
[C]	1 - 16	Input/Output connection terminals	
[D]	AUX -/+	Ancillary power-supply terminal	
[E]	Holes for the grounding bar screws		
[F]	CAN drive connector (opposite)		

LED IFM16IO	Colour	On solid	Flashing
CAN	Blue	Activity on the CAN communication BUS	
FAULT	Yellow	Short circuit on AUX terminals	
OUT	Green	At least one of the outputs on terminals 1-16 is active	
IN	Red	At least one of the inputs on terminals 1-16 is active	

IFM16IO module - technical specifications

Power supply voltage		19-30 V ^{DC} supplied by IFM24160 module
Operating temperature		from -5°C to +40°C
Consumption @ 27.6V	stand-by	12mA
	maximum	25mA
Maximum voltage on I/O		0.1A @ 30V ^{DC}

Previdia216 Control Panel

The Previdia216 control panel is the base model of a Previdia Max system.

This model consists of a single cabinet with the following modules already installed:

- FPMCPU, front-plate module with main CPU unit
- IFM24160, internal power-supply module
- IFM2L, internal module for the management of two loops

The combination of these modules make the Previdia216 an analogue-addressable fire detection panel capable of managing two loops which accommodate different types of devices (detectors, input modules, outputs, call points, sounders, etc.).

This model can be expanded, by means of a combination of other modules installed in accordance with system requirements.

The Previdia216R control panel is the same as Previdia216 but comes in a red cabinet.



4.1 Inside the package

Inside the box you will find:

- Metal cabinet containing a motherboard (FPMCPU module), power supply model (IFM24160), a 2-loop module (IFM2L) and seals for the closure of the cable entries (already inserted).
- Installation manual
- Plastic bag containing:
 - 2 resistors @ 1KOhm 1W
 - 2 diodes @ 1A 1000V 1N4007
 - 2 keys for access to user level 2
 - wire for the connection of the battery to the power-supply unit with thermal probe
 - battery to battery connection wire
 - 4 screws for securing IFM modules to the grounding bar
 - 2 ferrites

The batteries and programming software are not included in the package. These accessory items must be purchased separately.

Installation

Note: *Installation of these fire detection panels must be carried out in full respect of the local fire codes, laws and bylaws in force, and in accordance with the instructions and guidelines herein.*

The control panel must be mounted in a place that is:

- Dry
- Far from electromagnetic interference (electrical equipment, heating units, air-conditioning units, radio transmitters, etc.)

The mounting location must satisfy all the requirements of the respective Fire Code, laws and bylaws in force.

The system must be installed in accordance with the following procedure:

1. Lay the cables
2. Connect all the devices to the BUS, loop and in the protected area
3. Install system peripherals
4. Mount the control panel to the wall
5. Install accessory modules
6. Power up the system
7. Test the system

5.1 Mounting a PRCAB cabinet

1. Remove the securing screws and door (*paragraph 3.1 - [D]*).
2. Remove the front-plate grounding conductor (*paragraph 3.1 - [C]*) and, if present, the CAN wire.
3. Push the hinge grips, located at the top and bottom of the door hinges, inwards (*paragraph 3.1 - [E]*) to release the cabinet front plate.
4. Remove the seals from the cable entries you intend using (*paragraph 3.1 - [I]*).

Note: *In order to guarantee the IP30 protection grade, do not remove any other seals.*

5. Pull the cables through the open cable entries.
6. By means of the holes on the back of the cabinet, mount it to the wall (*paragraph 3.1 - [G]*). Use anchor screws (stop screws) with 8mm diameter minimum.
7. Insert and secure the various modules inside the cabinet and on the front plate.
8. Replace the front plate and reconnect the grounding conductor and CAN wire.
9. Complete the wiring of the internal modules.

5.1.1 Affixing cabinets to one another

The cabinets can be attached together by aligning the bottom of one cabinet with the top of another.

This operation allows you to join together up to 4 cabinets.

1. Remove all modules and wire/cables from the cabinets,
2. Remove the seals from holes used for affixing cabinets together.
3. Align the cabinets and, using the bolts (supplied with each cabinet), secure them together (*paragraph 3.1 - [H]*).
4. Connect the CAN drive bars of each cabinet together using the CAN wire (supplied with each cabinet).
5. Install the necessary modules and proceed with the installation of the control panel.

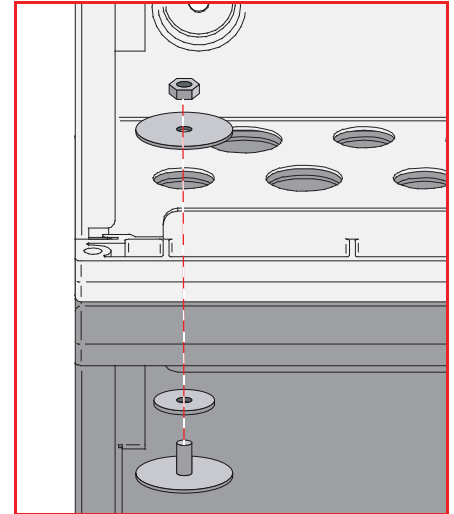

5.1.2 Mounting the PRCABSP kit

This kit allows the control panel to be mounted 5cm away from the wall and must be mounted before mounting the Previdia Max control panel.

1. Assemble the kit by attaching the distancing bracket (*paragraph 3.2 - [A]*) to the support bracket (*paragraph 3.2 - [B]*) by means of the interlocking dovetails (*paragraph 3.2 - [D]*).
2. Attach the assembled structure to the wall by means of the holes on the support (*paragraph 3.2 - [C]*).
3. Mount the cabinet to the distancing bracket by inserting the threaded rivets (*paragraph 3.2 - [E]*) through the holes on the back of the enclosure (*paragraph 3.1 - [G]*), then secure it in place using the supplied nuts.

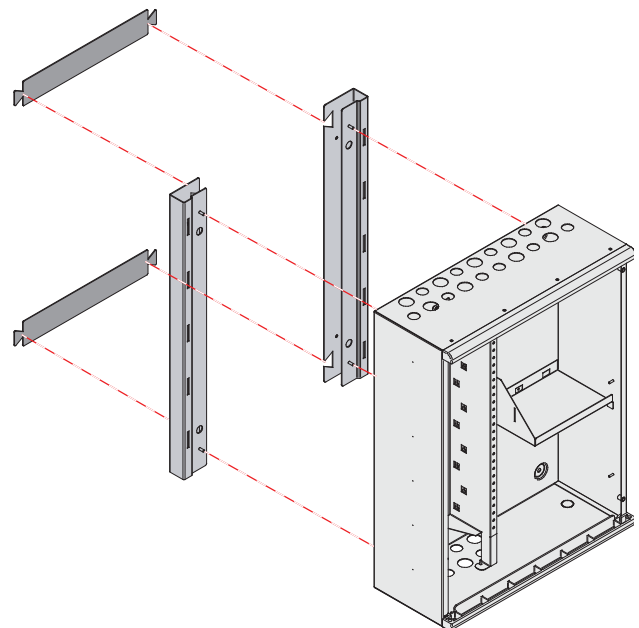

5.1.3 Mounting a PRCABRK kit

This accessory kit must be mounted to the 19" rack before the Previdia Max control panel is installed.

1. Attach one of the two support brackets (*paragraph 3.2 - [F]*) to each bar on the rack, using the available holes (*paragraph 3.2 - [G]*).
2. Mount the cabinet to the bracket by inserting the threaded rivets (*paragraph 3.2 - [H]*) through the holes on the back of the enclosure (*paragraph 3.1 - [G]*), then secure it in place using the supplied nuts.

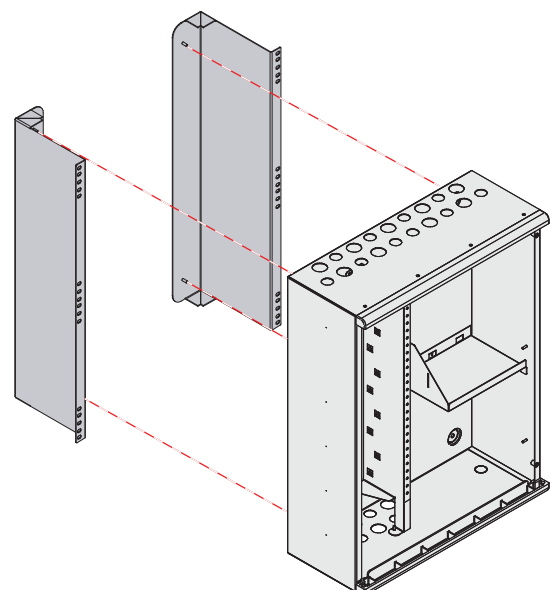

5.2 Mounting a PRREP, repeater enclosure

The PRREP repeater enclosure comprises two elements: an enclosure which can be wall or flush mounted (*paragraph 3.3 - [F]*) and a front plate for the mounting of a FPMCPU front-plate module (*paragraph 3.3 - [A]*).

1. Pull the connection cables through the cable entry on the back (*paragraph 3.3 - [G]*).
2. Mount the enclosure to the wall using the holes on the enclosure (*paragraph 3.3 - [H]*).
If you are flush mounting the enclosure, the folding flanges (*paragraph 3.3 - [I]*) can be used instead of screws.
3. Using the screws supplied with the module and the appropriate holes (*paragraph 3.3 - [D]* and *paragraph 3.4 - [H]*), mount the FPMCPU module to the front plate.
Ensure that the module speaker is properly positioned on the front plate (*paragraph 3.3 - [E]*).
4. Complete the wiring of the FPMCPU module (refer to *paragraph 5.3* and *paragraph 5.16*).
5. Attach the front plate with the wired module to the enclosure by means of the appropriate holes (*paragraph 3.3 - [C]*).

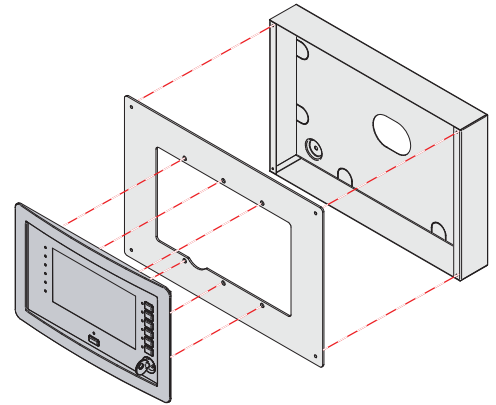

5.3 Mounting FPM modules to the front plate

The front-plate modules (FPMCPU, FPMNUL, FPMLED, FPMLEDPRN, FPMEXT) can be mounted to one of the apertures on the cabinet front plate (*paragraph 3.1 - [B]*). The FPMCPU module can also be mounted to front plate of the PRREP repeater enclosure (*paragraph 3.3 - [B]*).

1. Align the 6 holes on the module frame (*paragraph 3.4 - [H]*) with the 6 holes on the cabinet front-plate or repeater enclosure (*paragraph 3.3 - [D]*).
2. Secure the module in place by fastening the supplied screws into the aligned holes.
3. Connect the CAN BUS wire ([A] supplied):
 - if the module is mounted in the upper aperture, the CAN BUS wire must be connected between the module port ([B], *paragraph 3.4 - [N]*, *paragraph 3.5 - [D]*, *paragraph 3.10 - [N]*) and the CAN bar port ([C], *paragraph 3.1 - [P]*)
 - if the module is mounted in the lower aperture and another module is mounted in the upper aperture, the CAN BUS wire must be connected between module port ([D], *paragraph 3.4 - [N]*, *paragraph 3.5 - [D]*, *paragraph 3.10 - [N]*) and the appropriate port on the upper module ([E], *paragraph 3.4 - [O]*, *paragraph 3.5 - [E]*, *paragraph 3.10 - [O]*)
4. Fit the ferrite ([F], supplied) to the connected CAN BUS cable.
5. In the case of an FPMCPU module, complete the wiring on the LAN cable and BUS (refer to *paragraph 5.16*).

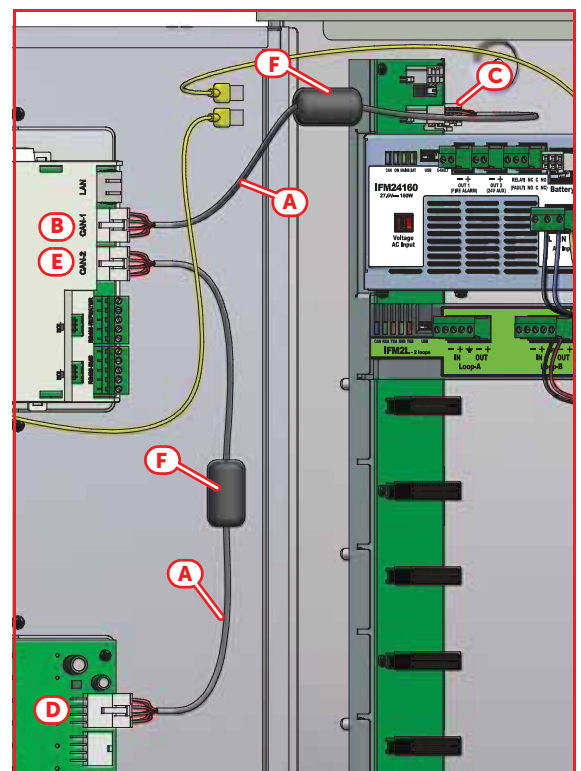
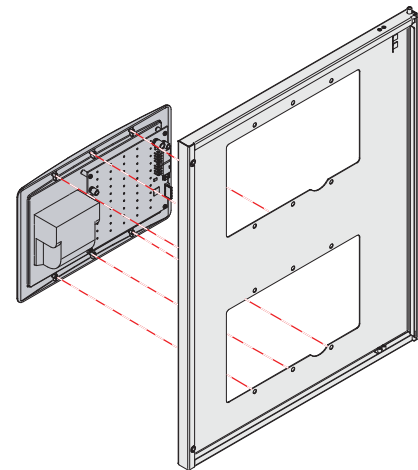

5.4 Mounting IFM internal modules

The internal modules (IFM24160, IFM2L, IFM4R, IFM4IO, IFMDIAL, IFM16IO, IFMNET, IFMLAN, IFMEXT) must be mounted in the special compartment inside the cabinet (*paragraph 3.1 - [K]*). There are two bars on either side of the compartment for mounting and connecting modules (*paragraph 3.1 - [J]* - [L]), up to 8 per cabinet.

1. Inside the compartment, find the position of the module that corresponds to one of the connectors on the PCB bar (*paragraph 3.1 - [N]*).
If you are installing an IFM24160 power-supply module, you must use the first connector at the top (*paragraph 3.1 - [R]*). When installing any other type of internal module, you can use this or any other connector that is free (*paragraph 3.1 - [S]*).
2. Position the module in such a way that it is on level with the desired connector on the bar then insert it in place by pushing it carefully to the left.
3. Affix the module to one of the holes on the grounding bar (*paragraph 3.1 - [L]*) using one of the supplied screws.
4. Complete the wiring on the internal module (refer to *paragraph 5.5.1 Cable entry* and the paragraphs regarding the wiring of each internal module).

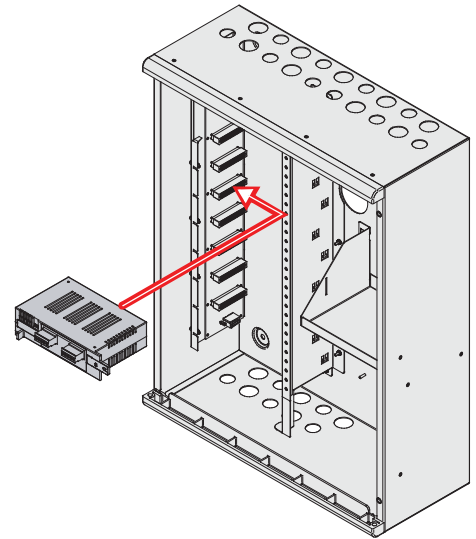

5.5 Control panel wiring

Attention: *Take care to remove all sources of power, including the batteries before starting any wiring operations.*

Note: *The ends of wires must not be soft soldered in points where they are subject to clamping.*

5.5.1 Cable entry

Use only the provided cable entries (remove the respective cable-entry seals) on the upper and lower parts of the cabinet and on the back [A].

The cables must run vertically behind the grounding bar (*paragraph 3.1 - [L]*) and must be secured to the appropriate hooks by cable ties [B].

The cable must run level with the terminal board of the module it is to be connected and its shield must be connected to the grounding bar [C]. Conductors without shields must be conveyed to the appropriate terminal board [D].

The unused cable entries must be closed by the supplied plastic seals.

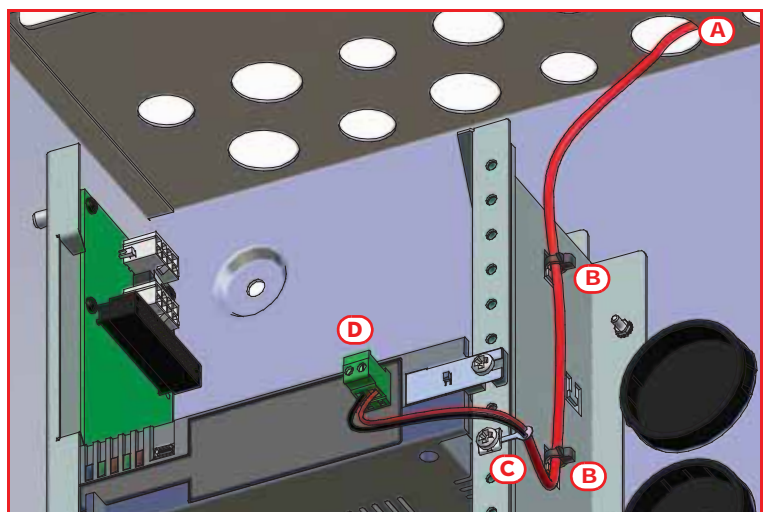

5.5.2 Mains connection

A dedicated input [A] must be provided for the mains power input terminal (230-115V~). The cable must be secured to the appropriate hooks by a plastic cable tie in order to avoid accidental dislodgement [B]. The cable must be protected by a ferrite (supplied) which must be affixed in the proximity of the terminals [C].

Ensure that the network cable runs along a separate path and that it does not interfere with any other cables.

This panel must be connected to a separate line on the Electrical Switchboard (Mains power supply). The line must be protected by a sectioning device which must be labeled and of "16A curve C" type.

The installation must be constructed, arranged and installed in compliance with the local laws in force regarding electrical safety.

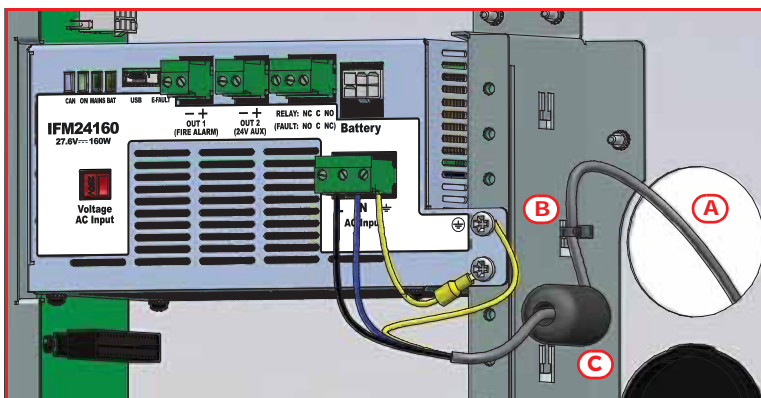

Cables: Connection cable type NYM 3 x 1.5 mm² or similar
Protected by ferrites (supplied)

5.5.3 Connection of system grounding conductors

Connect the mains earth conductor to the screw that must be inserted in the proper hole of the IFM24160 power-supply module (⊕, [A], paragraph 3.6 - [I]).

The earth conductor must be connected to earth on the electrical panel which supplies the control panel.

The grounding bar ([B], paragraph 3.1 - [L]) diverts undesirable current to ground in order to protect the control panel and its peripherals. Therefore, to ensure proper functioning, make certain that the ground bar is properly connected to:

- the wire with eyelet terminal, by means of the appropriate hole ([C], paragraph 3.6 - [J]); this wire must be connected to the IFM24160 module earth terminal (⊕, [D], paragraph 3.6 - [H])
- the internal modules, by means of the appropriate screws [E]
- the front plate, by means of the wire ([F], paragraph 3.1 - [C]) coming from the soldered end to which the ground wire of the FPMCPU [G] (paragraph 3.4 - [G]) must be connected to.
- the cable shields, by means of cable-gland screws [H].

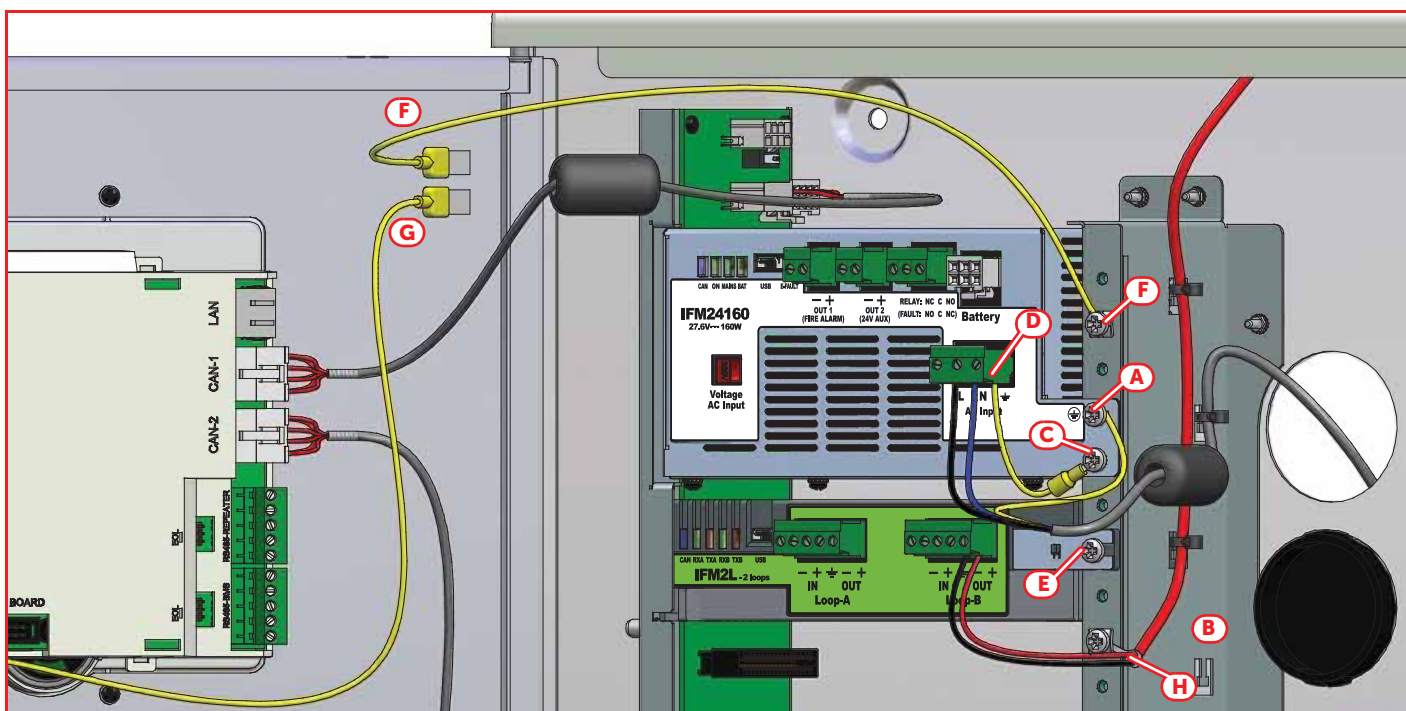

5.5.4 Multi-PRCAB cabinet wiring

Once the cabinets are affixed to one another, the CAN drive bars of each cabinet ([A], [B], paragraph 3.1 - [J]) must be connected together. To connect the CAN drive bars, use the BUS cable supplied with every PRCAB [C].

The two wires of this cable must be inserted, one into the lower connector of the CAN drive bar of the cabinet above ([D], paragraph 3.1 - [Q]), and the other into the upper connector of the CAN drive bar of the cabinet below ([E], paragraph 3.1 - [O]).

In the same way, it is convenient to connect the grounding wires of the cabinets that are attached together.

For this purpose, use the proper cable supplied with every PRCAB [F] and connect to each other the grounding bars of the two adjacent cabinets ([G], paragraph 3.1 - [L]).

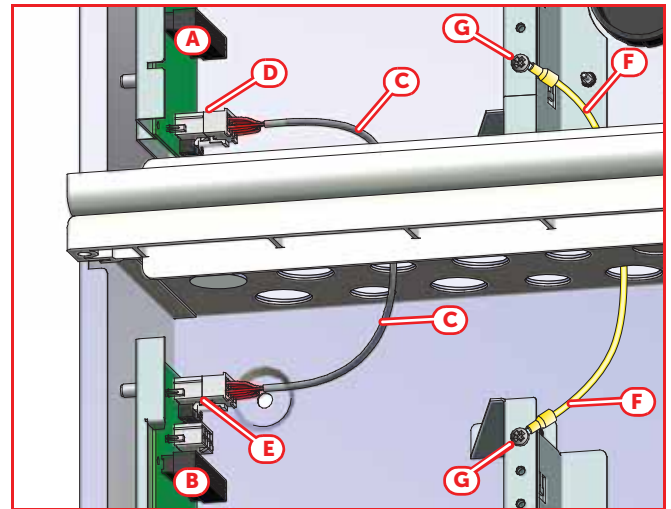

5.6 IFM24160 module wiring

As well as the terminal board for the mains power supply and the connector for the batteries, the IFM24160 power-supply module also provides two supervised outputs capable of supplying 27.6V in active status and a relay (voltage-free contacts C,NC,NO).

5.6.1 Battery connection

The batteries must be connected to the IFM24160 module by means of the supplied wire. The wire comprises the connectors for the battery terminals and thermal probe (NTC) for temperature-based charge voltage compensation.

1. Insert the batteries into the battery compartment inside the cabinet (paragraph 3.1 - [M]).
2. Using the battery wire ([A]), connect the batteries together.
3. Connect the wire with the eyelet terminals to the terminals of the batteries ([B]).

Attention: *Ensure that the polarity is correct.*
 Red - positive
 Black - negative

4. Connect the battery wire connector to the connector on the power supply module ([C], paragraph 3.6 - [G]).

Connection of the batteries before the mains voltage is present will not activate the system. Once the mains voltage is supplied, the power-supply module will connect the batteries automatically and initialize the circuits which manage them.

5. The thermal probe must be positioned on the side of the battery and held in place by a strip of tape ([D]).

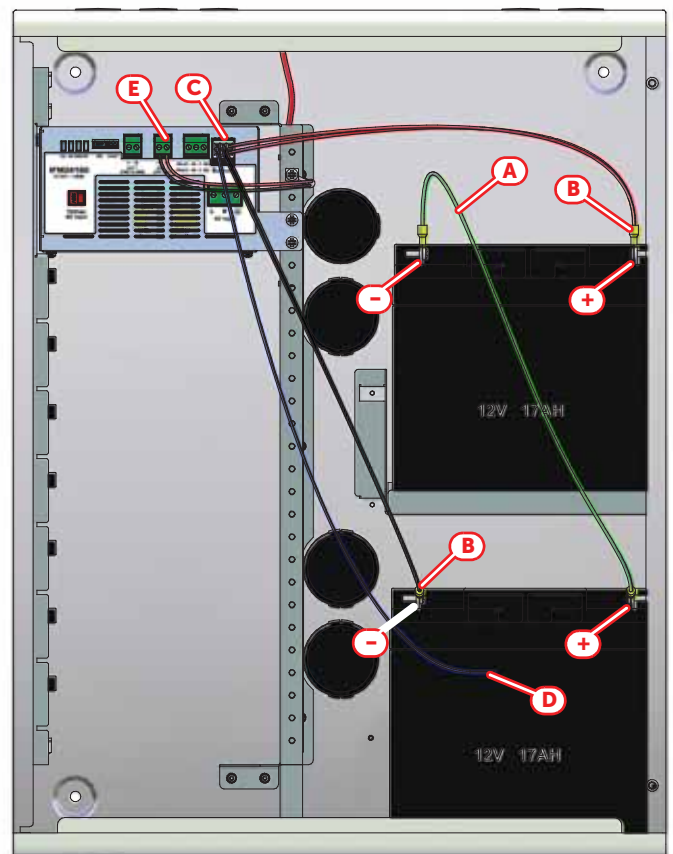

5.6.2 Output connection

Each output of the IFM24160 module can be configured to activate specific conditions. If left at their default settings, the three outputs will be as follows:

- OUT 1 (paragraph 3.6 - [D]), supervised output which activates in the event of a generic fire alarm
- OUT 2 (paragraph 3.6 - [E]), constantly active output (27.6V constant) for powering external devices
- RELAY (paragraph 3.6 - [F]), voltage free contact which activates in the event of fault

Each connection to these outputs ([E]) must be carried out in accordance with the instructions in paragraph 5.5.1.

Cables: 2-wire shielded cable
 Proper section (minimum 0.5mm², maximum 2.5 mm²)
 Compliant with local laws and regulations in force

Connection of polarized devices (sounders, etc.) to the OUT outputs

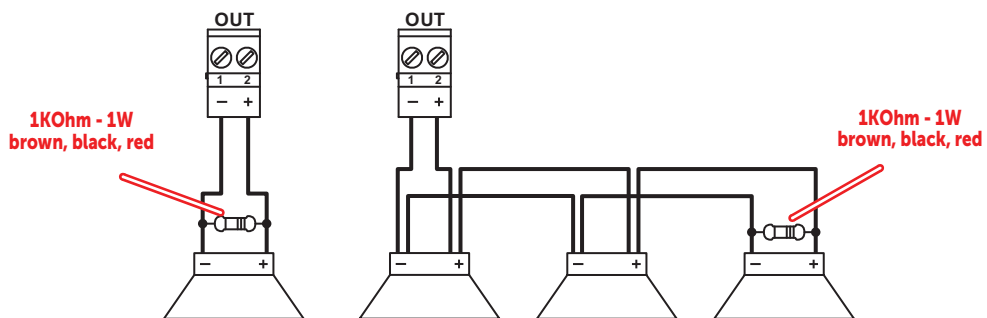

The polarities refer to the active status of the output, the polarities invert for stand-by status.

EN54: If the control panel default settings are left unchanged, the OUT 1 output will result as being configured as a type C output for the connection of audible/visual signalling devices. The output will activate in the event of any type of fire-alarm condition.

Connection of non-polarized devices (relays, etc.) to the OUT outputs

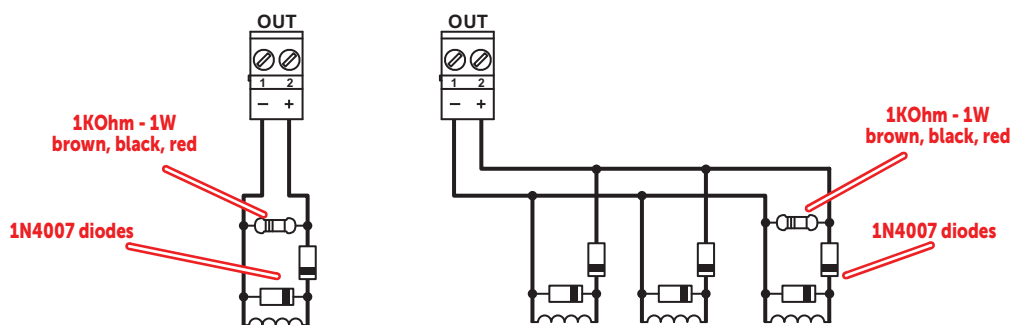

The polarities refer to the active status of the output, the polarities invert for stand-by status.

Connection of a generic device to the RELAY output

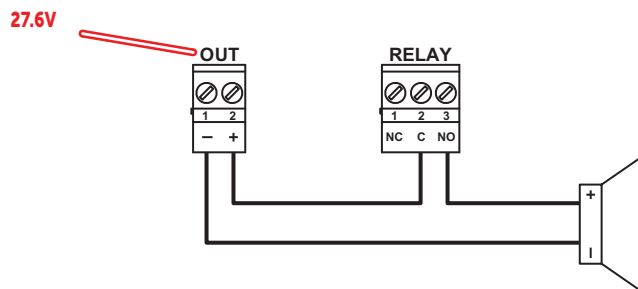

The OUT output illustrated in the diagram is used as a power source and is programmed as continuously active. The illustrated connection does not supervise the cable and does not signal connection faults.

All voltage free relay contact can only be connected to SELV circuits.

EN54:

If the control panel default settings are left unchanged, the RELAY output will result as being configured as a fault signalling output.

In compliance with regulations the output will also result "inverted" in order to switch to fault condition when the system is completely without power.

Therefore, in stand-by status (no faults present on the system) terminals C and NC will be closed, whereas terminals C and NO will be open.

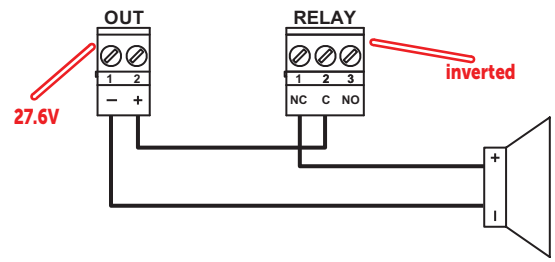

5.7 IFM2L internal module wiring - loop connection

The connection circuits of the peripheral detection/activation devices are defined as "loops". These loops start from the output terminals, run through the entire protected area connecting in parallel all the system devices before re-entering on the input terminals.

The loop utilizes the same two wires for the power supply to devices and for two-way communication. Due to electrical incompatibility, different brand devices (i.e. devices using different protocols) cannot co-exist on the same loop. However, the loops can be programmed separately in such a way as to allow the system to manage different brand devices on different loops.

Loops are made by means of a two-wire shielded cable with proper wire section (refer to the following cable specifications) and in compliance with local laws in force.

The wiring must be completed in a loop in order to guarantee the tolerance of wire-cutting or short-circuit on the cable.

Cables:

2 wire shielded cable

Twisted 5/10cm

Total maximum capacity 0.5uF

Maximum length 2000m

Maximum resistance (considering the sum of the positive and negative conductor) 40Ohm

It is necessary to consult the configuration software, Previdia/STUDIO, for the proper cable sizing in relation to the power consumption of the connected devices, or to the following table for a rough estimate:

Total loop length	Wire section	American Wire Gauge
Up to 1000m	2 x 1 mm ²	17 AWG
Up to 1500m	2 x 1.5 mm ²	16 AWG
Up to 2000m	2 x 2 mm ²	14 AWG

The cable shield must be connected to the grounding bar at one end only.

For the connections of the various devices refer to the instructions supplied with the devices themselves.

The following diagram illustrates the proper completion of the loop wiring. Starting from Loop-A/B OUT terminals on the IFM2L module ([A], paragraph 3.7 - [C] - [D]) proceed with the connection of the peripheral devices located in the area protected by the system ([B]) and re-enter on Loop-A/B IN terminals ([C]).

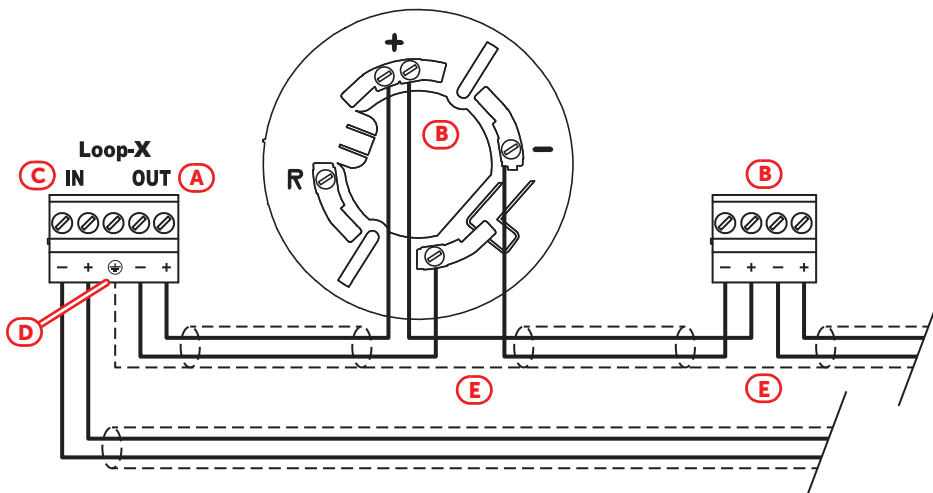

When connecting the loop devices it is not necessary to follow the input/output order indicated in the figure. Connect the cable shield only at the start of the loop (*[D]*), the shield can be connected to the terminal indicated in the figure or directly to the grounding bar). Take care to link the interrupted shields in correspondence with the device connections (*[E]*).

EN54: A Previdia Max control panel can support up to 3840 fire detectors and/or manual call points (240 devices per loop).

5.8 IFMNET internal module wiring - Hornet+ network connection

The connection of two or more control panels in a Hornet+ network can be achieved by means of two RS485 communication ports (*paragraph 3.11 - [C] - [D]*).

Each connection in the network must be completed in accordance with the instructions in *paragraph 5.5.1*.

Cables: 2 wire shielded cable
 Typical impedance 120Ohm
 Maximum length 1000m (between two successive control panels)
 Compliant with local laws and regulations in force

The connection must be a loop connection and must respect the direction of the wiring: the terminals on the terminal board of PORT-B must be connected with their counterparts on the terminal board of PORT-A of the next control panel; whereas, the terminals on the terminal board of PORT-A must be connected to their counterparts on the terminal board of PORT-B of the previous control panel.

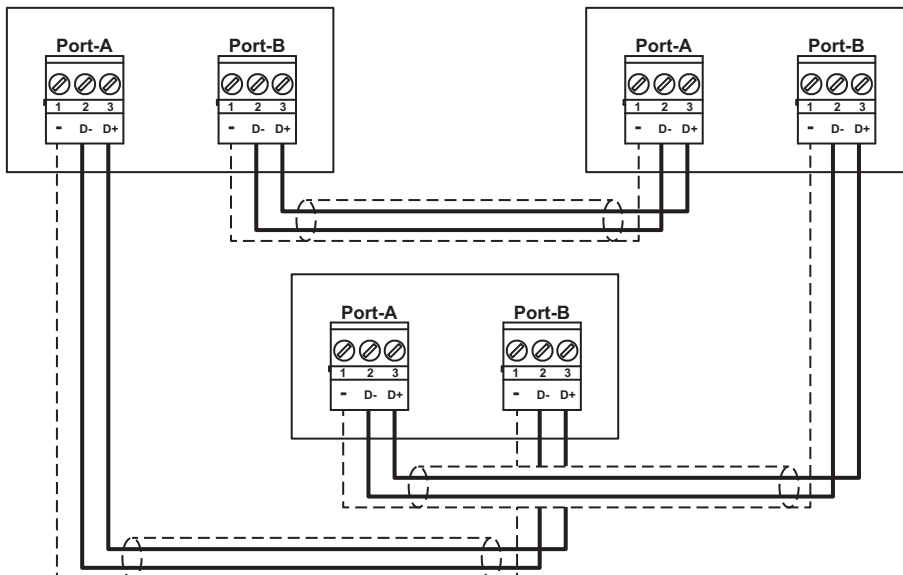

5.9 IFM4R internal module wiring

Cables: 2/3 wire shielded cable
 Proper section (minimum 0.5mm², maximum 2.5 mm²)
 Compliant with local laws and regulations in force

Each connection to this output must be completed in accordance with the instructions in *paragraph 5.5.1*.

All voltage free relay contact can only be connected to SELV circuits.

Each of the 4 relay outputs on the module must be connected in accordance with the following wiring diagram:

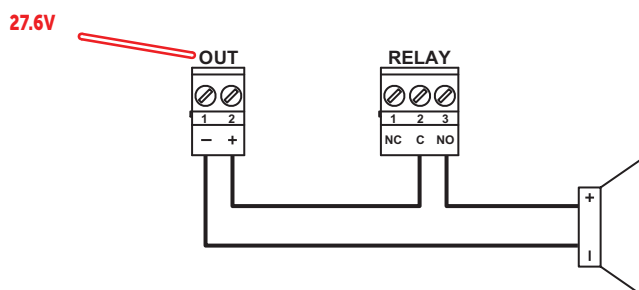

The OUT output illustrated in the diagram is used as a power source and is programmed as continuously active.

The illustrated connection does not supervise the cable and does not signal connection faults.

EN54:

If you wish to configure a RELAY output as a fault signalling output, you must complete the connections as shown in the wiring diagram opposite.

In compliance with the regulations in force, the output must be configured as "inverted" in order to switch to fault condition when the system is completely without power.

Therefore, in stand-by status (no faults present on the system) terminals C and NC will be closed, whereas terminals C and NO will be open.

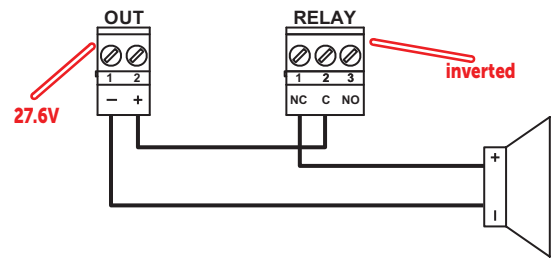

5.10 IFM4IO internal module wiring

Each of the 4 IN/OUT channels of the IFM4IO module (*paragraph 3.13 - [C]*) must be configured as:

- supervised output
- input
- conventional zone
- 4-20m gas input

Each connection to this channel must be carried out in accordance with the indications in *paragraph 5.5.1*.

Cables:

2 wire shielded cable

Proper section (minimum 0.5mm², maximum 2.5 mm²)

Compliant with local laws and regulations in force

Connection of polarized devices (sounders, etc.) to channels configured as outputs

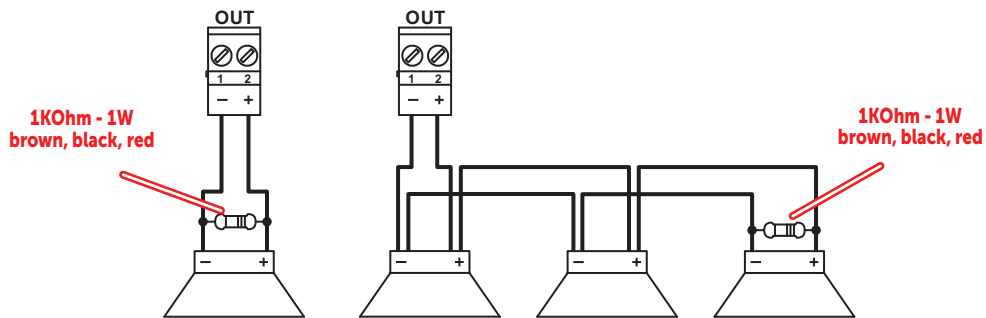

The polarities refer to the active status of the output, the polarities invert for stand-by status.

Connection of non-polarized devices (relays, etc.) to channels configured as outputs

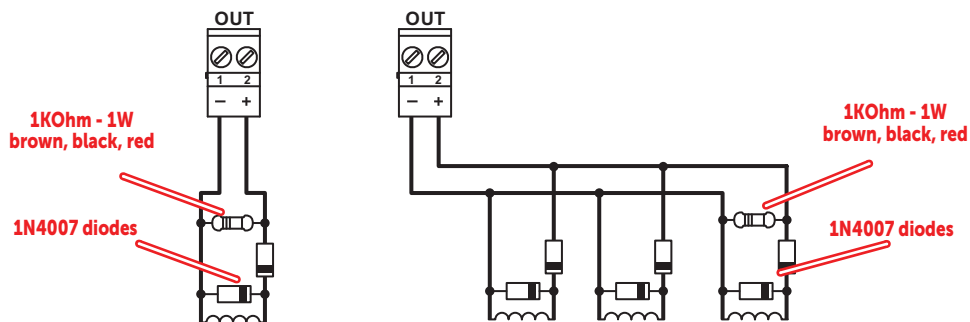

The polarities refer to the active status of the output, the polarities invert for stand-by status.

Connection of devices with an alarm output to channels configured as input

The wiring diagram illustrates a connection made to one of the channels of the IFM4IO module [A], configured as input. The connected device [B] is equipped with a normally open output for alarm signalling [C].

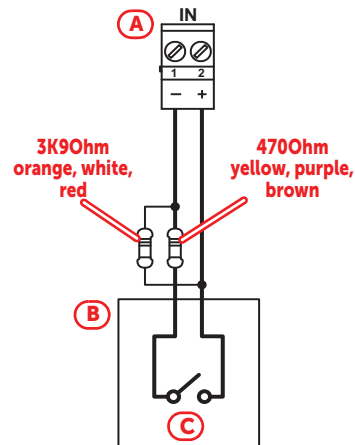

Connection of devices with alarm and fault outputs to channels configured as input

The wiring diagram illustrates a connection made to one of the channels of the IFM4IO module [A], configured as input. The connected device [B] is equipped with a normally closed fault signalling output [C] and a normally open alarm signalling output [D].

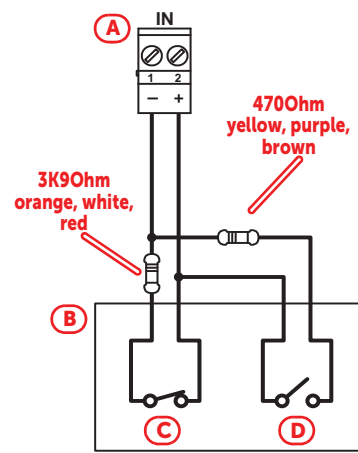

Connection of devices with alarm, early warning and fault outputs to channels configured as input

The wiring diagram illustrates a connection made to one of the channels of the IFM4IO module [A], configured as input. The connected device [B] is equipped with a normally-closed fault signalling output [C], a normally-open alarm signalling output [D] and a normally-open early warning signalling output [E].

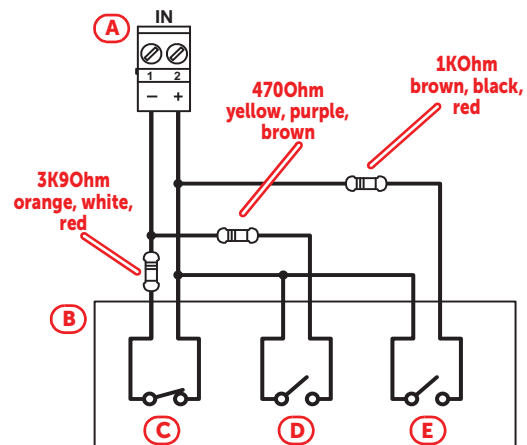

Connection to channels configured as conventional line

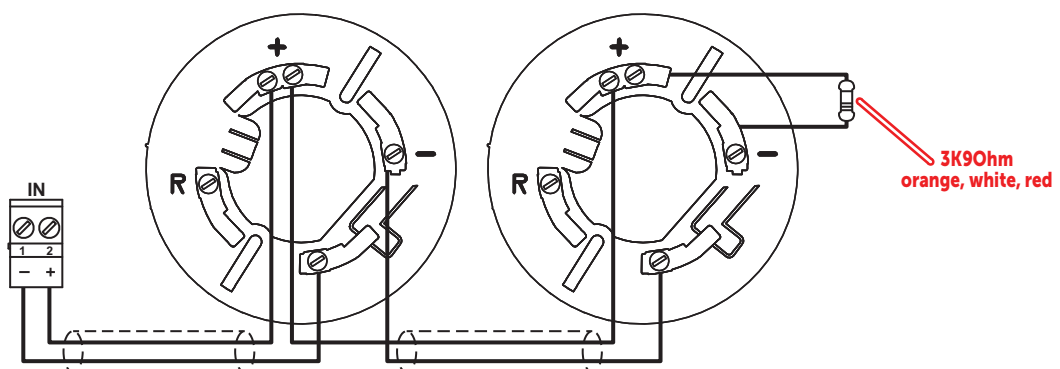

Connection to channels configured as 4-20mA gas input

The wiring diagram illustrates a connection made to one of the channels of the IFM4IO module [A], configured as gas output inclusive of a generic device with a 4-20mA output [B] powered from a 24V source [C].

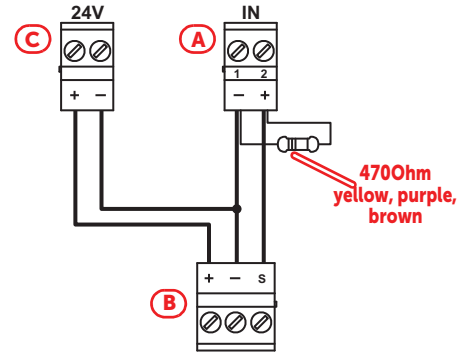

5.11 IFMDIAL internal module wiring

Cables: Compliant with local regulations in force

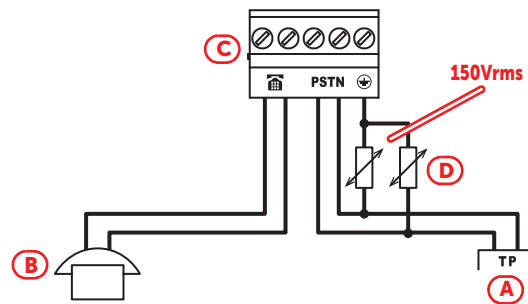

Connect the telephone line [A] to the PSTN terminals and telephone device or the internal phone line [B] to the terminals  on the IFMDIAL module ([C], paragraph 3.9 - [E]).

In order to protect the control panel against the discharge of atmospheric electricity, the manufacture strongly advises the use of the two 150Vrms varistors [D]; these varistors must be connected between the grounding terminal  and the PSTN terminals.

5.12 IFM16IO internal module wiring

Each of the 16 IN/OUT channels of the IFM16IO module (paragraph 3.14 - [C]) can be configured as non-supervised input or output.

If the connection requires, the module has AUX terminals (paragraph 3.14 - [D]) for a 27V ancillary power supply.

Each connection to this channel must be carried out in accordance with the indications in paragraph 5.5.1.

Cables: 2 wire shielded cable
Proper section (minimum 0.5mm², maximum 2.5 mm²)
Compliant with local laws and regulations in force

Connection of devices to channels configured as output

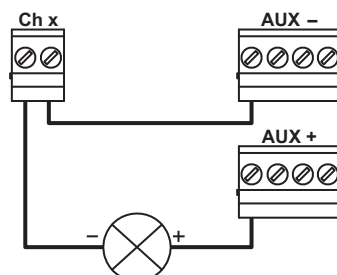

Connection of devices to channels configured as input

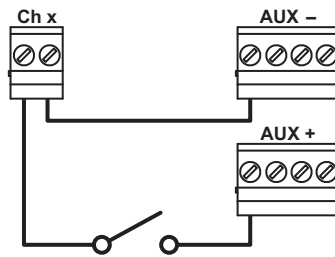

5.13 IFMLAN internal module wiring

The screw terminals of the IFMLAN module (*paragraph 3.8 - [F]*) are not available for any type of connection. For future use

5.14 IFMEXT internal module wiring

The IFMEXT module provides 7 terminals for the connection of signalling, activation and control devices linked to the apparatus of the fire extinguishment system.

- 3 input terminals:
 - PRESSOS. (*paragraph 3.10 - [C]*)
 - STOP-EXT (*paragraph 3.10 - [D]*)
 - MAN-EXT (*paragraph 3.10 - [E]*)
- 4 output terminals:
 - VALVE (*paragraph 3.10 - [F]*)
 - HOLD (*paragraph 3.10 - [G]*)
 - PRE-EXT (*paragraph 3.10 - [H]*)
 - RELEASED (*paragraph 3.10 - [I]*)

Each connection to these terminals must be completed following the instructions in *paragraph 5.5.1*.

Cables: 2 wire shielded cable
 Proper section (minimum 0.5mm², maximum 2.5 mm²)
 Compliant with local laws and regulations in force

Note: *In order to comply with EN12094-1 standard requirement, if more than one extinction channel is managed by a single Previdia Max panel (more than one IFMEXT module installed on a single panel) a backup FPMCPU unit have to be installed in the system, this backup unit will provide the disablement function for each extinction channel also in the unlikely event of main FPMCPU system fault.*

Connection of Input terminals

The wiring diagram illustrates the connection to be completed on the input terminals. The devices to be connected are: the normally open input of a pressure switch [A], a normally-open output of a command which interrupts extinguishment [B] and a normally-open output of an alarm activation command [C]. The resistances to be utilized are the same for each channel

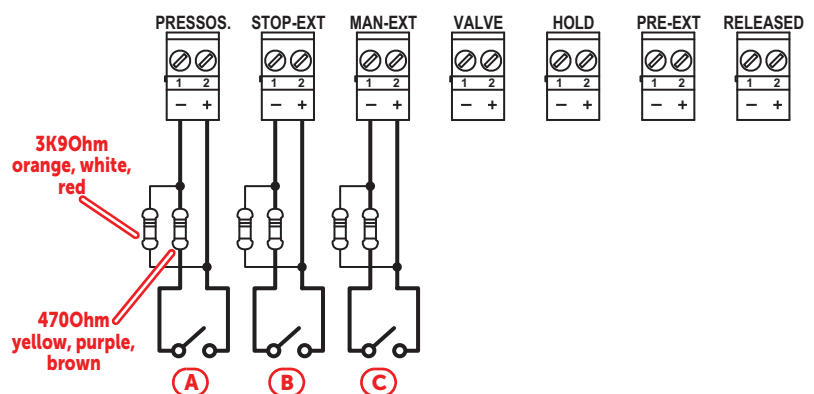

Connection of output channels

The wiring diagram illustrates the connection to be completed on the input channels. The connectible devices are: a valve for extinguishant gas discharge [A], a device which signals the suspension of the extinguishment procedure [B], a device which signals the activation of the pre-extinguishment time [C] and a device which signals the completed extinguishant gas discharge operation [D]. The resistances to be utilized are the same for each channel

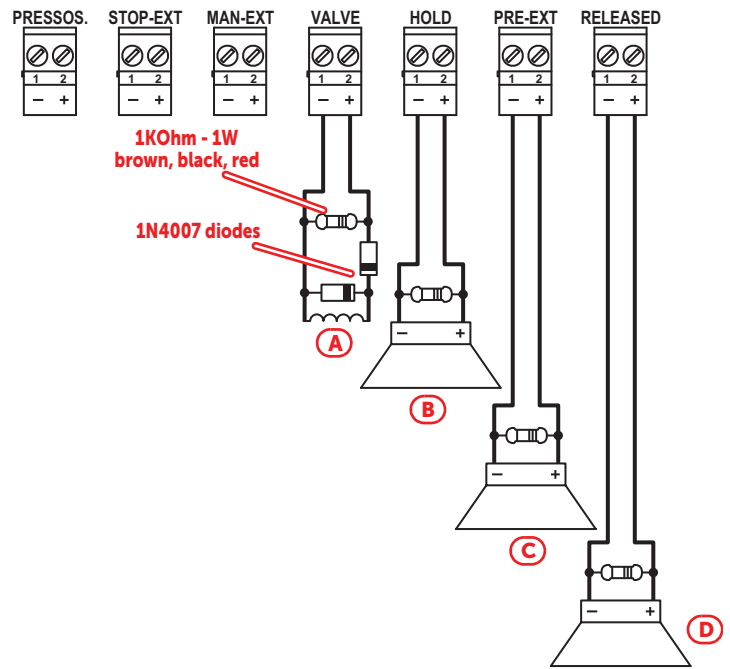

5.15 J and E type relay output wiring (EN54)

Cables: 2-wire shielded cable
 Proper section (minimum 0.5mm², maximum 2.5 mm²)
 Compliant with local laws and regulations in force

EN54: To make a type J output (output for the activation of a remote fault-signalling device as required by EN54-2, [A]), you must use a remote communication device which is compliant with EN54-21 regulations [B] and which must have a normally-open supervised activation input [C], a normally-closed fault signalling output [D] and a normally-open output to provide feedback indicating successful communication [E].

This is done by making the connection illustrated in the figure, using a relay output (of an IFM24160 module, IFM4R module or relay module) [A] configured as "communicator fault condition output" and an input of an I/O module [F] configured as "communicator fault condition input".

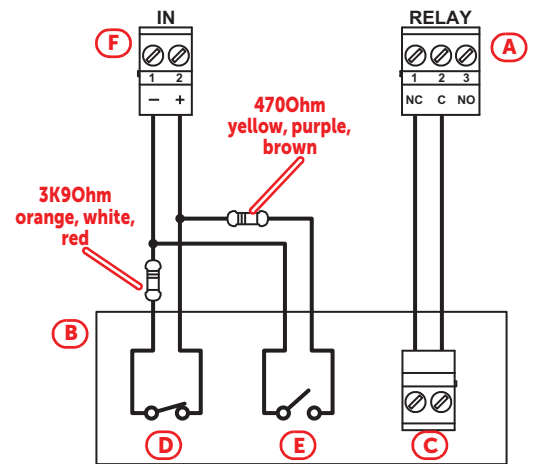

EN54: To construct a type E output (output for the activation of a remote alarm-signalling device as required by EN54-2, [A]), you must use a remote communication device which is compliant with EN54-21 regulations [B] and which has a normally-open supervised activation input [C], a normally-closed fault signalling output [D] and a normally-open output to provide feedback indicating the successful communication [E].

This is done by making the connection illustrated in the figure, using a relay output (of an IFM24160 module, IFM4R module or relay module) [A] configured as "communicator alarm condition output" and an input of an I/O module [F] configured as "communicator fault condition input".

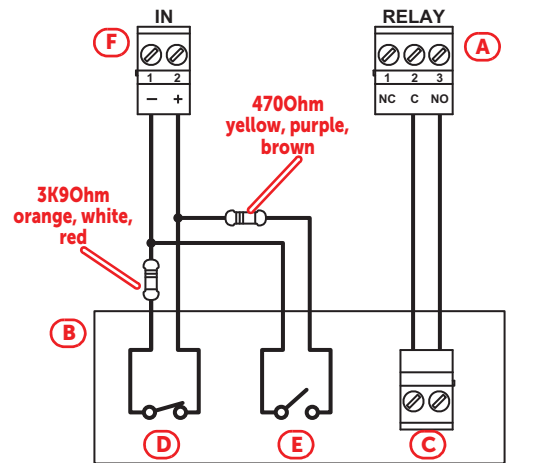

5.16 FPMCPU front-plate module wiring - repeater connection

The wiring for the FPMCPU module provides for a connection to the Ethernet network via LAN cable and to the RS485 BUS which must be set up between the Previdia Max control panel and the system repeaters.

The connection to the Ethernet network is obtained through the LAN port on the module (*paragraph 3.4 - [M]*).

Cables:

 UTP cable with RJ45 connectors
 Protected by ferrites (supplied)
 Compliant with local laws and regulations in force

The BUS connection is achieved through the RS485 communication port on the module PCB (*paragraph 3.4 - [P]*). Two connection methods are possible, depending on whether the power supplied to the control panel is sufficient enough to power the repeaters, due to the loads required or the length of the cables.

Cables:

 4 wire shielded cable
 Maximum length (from control panel to last repeater)
 1000m
 Protected by ferrites (supplied)
 Compliant with local laws and regulations in force

Each connection in the network must be completed in accordance with the instructions in *paragraph 5.5.1*.

Connection of repeaters using power supplied by the control panel

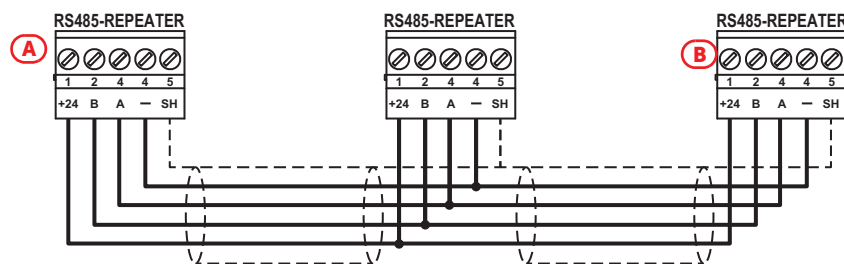

The jumper for the position on the BUS (*paragraph 3.4 - [Q]*) must be inserted in the EOL position EOL for the control panel [A] and for the end-of-line repeater [B].

Connection of repeaters using power supplied by an external power-supply

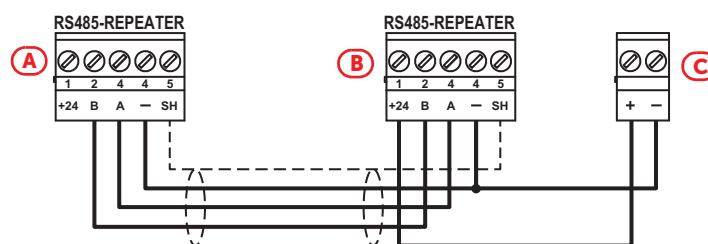

In this case the power to the repeaters [B] is not supplied by the control panel [A] but by an external power supply [C].

EN54:

 The power-supply unit employed must be EN54 standard compliant.

System test

INIM Electronics recommends that the entire system be checked completely at regular intervals.

For the instructions for system testing and maintenance refer to the *Manual for system configuration, commissioning and maintenance*.

Replacement and disposal of used devices

When replacing obsolete devices, disconnect the devices concerned then complete the connections of the new devices in compliance with the instructions printed on the respective leaflets.

Contact your local municipal offices for information regarding the disposal of used electronic devices.

Do not burn used electronic devices, or allow them to pollute the environment (countryside, rivers, etc.). Electronic devices must be disposed of in a safe environment-friendly way. In order to avoid short-circuits, take all the necessary precautions when removing used batteries.

Information about disposal of batteries and accumulators

(Applicable in Countries with separate collection systems)



This marking on batteries and/or their manual and/or their packaging, indicates that batteries of these products, at the end of their working life, should not be disposed of as unsorted municipal waste, but must be object of a separate collection. Where marked, the chemical symbols Hg, Cd o Pb indicate that the battery contains mercury, cadmium or lead above the reference levels of the directive 2006/66/EC. If batteries are not properly disposed of, these substances, together with other ones contained, can cause harm to human health and to the environment.

To protect human health and the environment, to facilitate treatment and recycling of materials, separate batteries from other kind of waste and use the collection scheme stated in your area, in accordance to current laws.

This product contains a lithium metal button cell type CR2032. Furthermore, for proper operation and compliance with product standards, the installer must install a couple of lead-acid accumulators for backup use type NPL24-12I or NP 17 -12-FR or equivalent (not supplied).

Before disposing of the above, it's appropriate to remove them from their holders avoiding to damage them or causing short circuits.



ISO 9001 Quality Management
certified by BSI with certificate number FM530352

Centobuchi, via Dei Lavoratori 10
63076 Montepandone (AP) Italy
Tel. +39 0735 705007 _ Fax +39 0735 704912

info@inim.biz _ www.inim.biz



DCMIINEOPREVIDIA-120-20180626